

# **STANDARD BIDDING DOCUMENT**

**(PARTIAL TURNKEY CONTRACT)**

**FOR**

**RURAL/URBAN ELECTRIFICATION WORKS  
OF **XXXX** (NAME OF DISTRICT) DISTRICT OF  
**XXXX** (NAME OF STATE) UNDER  
DEENDAYAL UPADHYAYA GRAM JYOTI  
YOJANA/INTEGRATED POWER  
DEVELOPMENT SCHEME**

**VOLUME-III**

**(TECHNICAL SPECIFICATONS &  
DRAWINGS)**

**Section-I : Technical Specifications**

**Section-II : Tender Drawings**

**SPECIFICATION No.:.....**

**DOCUMENT NO.:.....**

**VOLUME-III: SECTION – I**

**TECHNICAL SPECIFICATIONS**

**Section-I**

**Technical Specification for Equipment's**

All materials required to complete the work as per given specifications & drawings etc. must be manufactured and supplied using fresh raw material. Re-moulded, re-circulated materials are not acceptable. The procurement of materials must be made by the contractor directly from manufacturer or through authorized dealer/distributors. Documentary evidences to this effect are to be made available to Employer for necessary checks/verification of source of supply of materials. Second hand materials/ partial used materials/ used materials would not acceptable.

Climatic condition details are given with various materials specifications however, bidder shall note that materials covered under project specific DDUGJY works shall be utilized in that particular project only. Hence, the geographical location of that particular project site and its associated climatic condition shall be applicable for all the materials of that particular project.

Contents

1. Power Transformers .....	5
2. Single Phase Oil Immersed Distribution Transformers (Outdoor Type) .....	41
3. 3-Phase Distribution Transformers 11 or 33 kV/415-240V (Outdoor Type) .....	64
4. ACSR CONDUCTOR.....	99
5. AAA CONDUCTOR.....	200
6. PCC Poles .....	203
7. Tubular Steel Poles for Overhead Lines.....	204
8. Hot Rolled Steel Beams (Joists).....	207
9. Mild Steel Channel, Angle And Flat .....	209
10. 11 & 33 KV Outdoor Type Current Transformer .....	210
11. 33 & 11 kV Outdoor Type Potential Transformer .....	214
12. 11 kV AND 33 kV Vacuum Circuit Breakers.....	218
13. 11 kV 350MVA 1250 AMP VCB Switchgear Panels (MC VCB) - Indoor.....	226
14. Control&RelayPanelfor33kVFeederwithDirectionalorNon-directional O/CandE/Fprotectionand33/11kVTransformerPanelwith&without Differential Protection for various 33/11 kVSub-Station.....	237
15. Batteries and Charger .....	304
16. LT upto (1100 V) XLPE Insulated .....	329
17. LT Aerial Bunched Cables .....	352
18. XLPE Power Cables (11kV & 33 kV) .....	364
19. 10KVA 1-Phase, 16 KVA (1/ 3-Phase) & 25 KVA 3-Phase L.T. Distribution Box (with MCCBs).....	372
20. 63,100,200 & 315 kVA L.T. Distribution Box.....	377
21. 11kV Porcelain Insulators and Fittings .....	386
22. Porcelain Insulators and Insulator Fittings for 33 kV Overhead Power Lines .....	400
23. 33 kV and 11 kV Post Insulator .....	407
24. 11 kV/22 kV/33 kV Composite Insulators .....	412
25. Guy Strain Insulators .....	430
26. Helically Formed Fittings for 11 kV and LT Lines.....	433
27. Insulation Piercing Connectors, Anchor (Dead End) & Suspension Accessories & Other Accessories for Aerial Bunched Cables for Working Voltage upto and including 1100 Volts.....	450
28. 11 kV and 33 kV Isolators .....	482
29. 11 kV and 33 kV Air Break Switches .....	487
30. 11 kV Drop Out Fuse Cut Outs .....	492
31. 33& 11 kV Station Class Lightning Arrestor & 11 kV Distribution Class Surge Arrestors.....	498
32. LED Self Ballasted Lamps (Retrofit LED Lamp) .....	517
33. 1KV & 33 KV Metering Units .....	519
34. Energy Meter .....	527
35. Earthing Coil .....	558
36. Earthing Conductors .....	559

37. Deep Drawn Metal Meter Box (MMB) for Single Phase Energy Meter. ....	560
38. Three Phase 4 Wire L.T. Distribution Box for Aerial Bunched Conductor.....	562
39. Deep Drawn Metal Meter Box (MMB) for Three Phase Energy Meter.....	564
40. Single Phase L.T. Distribution Box for Aerial Bunched Conductor.....	566
41. Cubicle (Metal Box) for Housing LT AC Three Phase Four Wire, CT Operated Static Energy Meter, Modern and 4 No. Epoxy Resin Cast CTs. ....	568
42. Earthing .....	571
43. Gi Earthing Pipe .....	575
44. GS Stay Sets (16 mm AND 20 mm) .....	577
45. GI Stay Wires.....	581
46. MCCB .....	584
47. H.R.C. Fuse.....	586
48. Triple Pole Switch Fuse Units with Neutral Links .....	587
49. Clamps & Connectors.....	590
50. Epoxy Based Protective Paint.....	591
51. Mid Span Compression Joint and Repair Sleeve .....	596
52. Terminal Block .....	604
53. Wiring .....	605
54. Equipment Erection Notes .....	606
55. Danger Notice Plates .....	607
56. Number Plate (Support) .....	611
57. Cable Glands and Lugs.....	613
58. Cables Tags and Markers .....	614
59. Earth Knobs for LT Lines .....	617
60. GI Wires .....	619
61. Hot Dip Galvanised GS Solid Wire.....	621
62. Material Properties and Other Technical Requirements for Heat Shrinkable Cable Terminations and Joints Suitable for XLPE Cables. ....	622
63. 4-in-1 & 6-in-1 DEEP DRAWN METAL METER BOX WITH MULTIPLE OUTGOING CONNECTOR (MOC) FOR SINGLE PHASE ENERGY METERS.....	623
64. 20-in-1 Meter Pillar Box (MPB) for single phase meters .....	626

**Power Transformers**

**1 SCOPE**

1.1 This specification provides for design, engineering, manufacture, assembly, stage inspection, final inspection and testing before dispatch, packing and delivery at destination stores by road transport, transit insurance of 3.15/5/6.3/8/10/12.5MVA, 33/11KV Power Transformer(s), complete with all fittings, accessories, associated equipment's, spares, 10% extra Transformer Oil, required for its satisfactory operation in any of the sub-stations of the purchaser.

1.2 The core shall be constructed either from high grade, non-aging Cold Rolled Grain Oriented (CRGO) silicon steel laminations conforming to H1B grade of BIS certified with lamination thickness not more than 0.23mm to 0.27mm or better (Quoted grade and type shall be used). The maximum flux density in any part of the cores and yoke at normal voltage and frequency shall be such that it should under 10% overvoltage condition should not be more than 1.9 Tesla. The supplier shall provide saturation curve of the core material, proposed to be used. Laminations of different grade(s) and different thickness (s) are not allowed to be used in any manner or under any circumstances.

1.3 The scope of supply includes the provision of type test. The equipment offered should have been successfully type tested within five years from date of tender and the design should have been in satisfactory operation for a period not less than three years as on the date of order. Compliance shall be demonstrated by submitting, (i) authenticated copies of the type test reports and (ii) performance certificates from the users, specifically from Central Govt./State Govt. or their undertakings.

1.4 The Power Transformers shall conform in all respects to highest standards of engineering, design, workmanship, this specification and the latest revisions of relevant standards at the time of offer and the employer shall have the power to reject any work or material, which, in his judgment, is not in full accordance therewith. The Transformer(s) offered, shall be complete with all components, necessary for their effective and trouble free operation. Such components shall be deemed to be within the scope of supply, irrespective of whether those are specifically brought out in this specification and /or the commercial order or not.

The Engineer reserves the right to reject the transformers if on testing the losses exceed the declared losses beyond tolerance limits as per IS or the temperature rise in oil and/or winding exceed the value, specified in technical particular or impedance value differ from the guaranteed value including tolerance as per this specification and if any of the test results do not match with the values, given in the guaranteed technical particulars and as per technical specification.

**2 SPECIFIC TECHNICAL REQUIREMENTS**

1	Rated MVA (ONAN rating)	3.15/5/6.3/8/10/12.5MVA
2	No. of phases	3
3	Type of installation	Outdoor
4	Frequency	50 Hz (± 5%)
5	Cooling medium	Insulating Oil (ONAN)
6	Type of mounting	On Wheels, Mounted on rails.
7	Rated voltage	
	a) High voltage winding	33KV
	b) Low voltage winding	11KV

8	Highest continuous system voltage		
	a) Maximum system voltage ratio (HV / LV)	36KV / 12 KV	
	b) Rated voltage ratio (HV / LV)	33KV / 11 KV	
9	No. of windings	Two winding Transformers	
10	Type of cooling	ONAN (Oil natural / Air natural)	
11	MVA Rating corresponding to ONAN Cooling system	100%	
12	Method of connection:		
	HV :	Delta	
	LV :	Star	
13	Connection symbol	Dyn11	
14	System earthing	Neutral of LV side to be solidly earthed.	
15	Intended regular cyclic overloading of windings	As per IEC-76-1, Clause 4.2	
16	a) Anticipated unbalanced loading	Around 10%	
	b) Anticipated continuous loading of windings (HV / LV)	110 % of rated current	
17	a) Type of tap changer (For 3.15, 5, 6.3, 8, 10 & 12.5 MVA only)		
	On or Off load tap changer as per BOQ		
	b) Range of tapping + 5% to -15% in 9 equal steps of 2.5% each for Off-load tap and in 17 equal steps of 1.25% each for On-load tap changer on HV winding		
18	Neutral terminal to be brought out	On LV side only	
19	Over Voltage operating capability and duration	112.5 % of rated voltage (continuous)	
20	Maximum Flux Density in any part of the core and yoke at rated MVA with +12.5% combined voltage and frequency variation from rated voltage and frequency.	1.9 Tesla	
21	Insulation levels for windings:- 1.2 / 50 microsecond wave shape Impulse withstand (KVP)	33KV 170	11KV 75
	a) Power frequency voltage withstand (KVrms)	70	28
22	Type of winding insulation		
	a) HV winding	Uniform	
	b) LV winding	Uniform	
23	Withstand time for three phase short circuit	2 Seconds	
24	Noise level at rated voltage and frequency	As per NEMA Publication No. TR-1.	

25 Permissible Temperature rise over ambient temperature shall be as per IS-2026

26 Minimum clearances in air (mm) :-                      Phase to Phase      Phase to ground

- |    |    |    |     |     |
|----|----|----|-----|-----|
| 27 | a) | HV | 400 | 320 |
| 28 | b) | LV | 280 | 140 |

28 Terminals

a. HV winding line end 36 KV oil filled communicating type porcelain bushings (Anti-fog type)

b. LV winding 12 KV porcelain type of bushing (Anti-fog type) – for outdoor 11 KV breakers

**(11KV Power cable shall be used for extending supply to 11KV breakers in case of indoor circuit breakers. The termination of 11KV cables on LV bushings shall be through extended copper busbar suitable to hold power cable termination. A metallic cable termination box, completely sealed, shall be installed on LV side of the transformer in which cable shall enter from bottom gland plates.)**

29 Insulation level of bushing

		LV	HV
	a) Lightning Impulse withstand (KV)	170	75
	b) 1 Minute Power Frequency withstand voltage (KV-rms)	70	28
	c) Creepage distance (mm) (minimum)	900	300
	30 Material of HV & LV Conductor	Electrolytic Copper	
31	Maximum current density for HV and LV winding for rated current	As per best practice	

32 Polarization index

(HV to LV, HV to Earth & LV to earth)

IR Test = 1 minute value / 15 secs. value will not be less than 1.5

IR Test = 10 minutes value / 1 minute value will not be more than 5 and less than 1.5

33 Core Assembly

Boltless type

34 Temperature Indicator

- |    |         |            |
|----|---------|------------|
| a) | Oil     | One number |
| b) | Winding | One number |

35. **Losses:** - The losses shall not exceed the value given below

MVA Rating	No-load losses (Fixed loss) KW	Load losses at 75°C KW	Percentage impedance voltage on normal tap and MVA base at 75°C
3.15	3	16	7.15
5	4	23	7.15
6.3	4.6	36	7.15
8	5.5	40	8.35
10	7	50	8.35
12.5	7.5	65	10



**2.1 MARSHALLING BOX**

A metal enclosed, weather, vermin and dust proof marshalling box fitted with required glands, locks, glass door, terminal Board, heater with switch, illumination lamp with switch etc. shall be provided with each transformer to accommodate temperature indicators, terminal block etc. It shall have degree of protection of IP55 or better as per IS:2147 (Refer Clause 3.12).

**2.2 CAPITALIZATION OF LOSSES AND LIQUIDATED DAMAGES**

Capitalisation of losses will be as per Annexure B which is attached herewith. No (+)ve tolerance shall be allowed at any point of time, on the quoted losses after the award. In case, the losses during type testing, routine testing etc are found above the quoted losses, the award shall stand cancelled. In such a case, the CPG money shall also be forfeited.

**2.3 PERFORMANCE**

- i) Transformers shall be capable of withstanding for two seconds without damage to any external short circuit, with the short circuit MVA available at the terminals.
- ii) The maximum flux density in any part of the core and yoke at rated Voltage and frequency shall be such that the flux density with +12.5% combined voltage and frequency variation from rated voltage and frequency shall not exceed 1.9 Tesla.
- iii) Transformers shall under exceptional circumstances due to sudden disconnection of the load, be capable of operating at the voltage approximately 25% above normal rated voltage for a period of not exceeding one minute and 40% above normal for a period of 5 seconds.
- iv) The transformer may be operated continuously without danger on any particular tapping at the rated MVA  $\pm$  1.25% of the voltage corresponding to the tapping.
- v) The thermal ability to withstand short circuit shall be demonstrated by calculation.
- vi) Transformers shall be capable of withstanding thermal and mechanical stress caused by any asymmetric and asymmetric faults on any winding.

**2.4 DRAWINGS/ DOCUMENTS INCORPORATING THE FOLLOWING PARTICULARS SHALL BE SUBMITTED WITH THE BID**

- a) General outline drawings showing shipping dimensions and overall dimensions, net weights and shipping weights, quality of insulating oil, spacing of wheels in either direction of motion, location of coolers, marshalling box and tap changer etc.
- b) Assembly drawings of core, winding etc. and weight of main components/ parts.
- c) Height of centerline on HV and LV connectors of transformers from the rail top level.
- d) Dimensions of the largest part to be transported.
- e) GA drawings / details of various types of bushing
- f) Tap changing and Name Plate diagram
- g) Type test certificates of similar transformers.

h) Illustrative & descriptive literature of the Transformer.

i) Maintenance and Operating Instructions.

**2.5 MISCELLANEOUS**

i) Padlocks along with duplicate keys as asked for various valves, marshalling box etc. shall be supplied by the contractor, wherever locking arrangement is provided.

ii) Foundation bolts for wheel locking devices of Transformers shall be supplied by the Contractor.

**2.6 DELIVERY**

The full quantity of the equipments shall be delivered as per the delivery schedule appended to this specification.

**2.7 SCHEDULES**

All Schedules annexed to the specifications shall be duly filled by the bidder separately.

**2.8 ALTITUDE FACTOR**

If the equipment is to be installed in the hilly area, necessary correction factors as given in the Indian Standard for oil temperature rise, insulation level etc. shall be applied to the Standard Technical Parameters given above.

**2.9 NAMEPLATE**

Transformer rating plates shall contain the information as given in clause 1.5 of IS-2026 (part-I). The details on rating plates shall be finalized during the detailed engineering. Further, each transformer shall have inscription of Employer's name. The name plate shall also include (i) The short circuit rating, (ii) Measured no load current and no load losses at rated voltage and rated frequency, (iii) measured load losses at 75 °C (normal tap only), (iv) D.C. resistance of each winding at 75 °C.

**3. SERVICE CONDITIONS**

The service conditions shall be as follows: (To be confirmed by PIAs per locality of project)		
	<b>Plain area</b>	<b>Hilly area</b>
Maximum altitude above sea level	1000m	5000m
Maximum ambient air temperature	50° C	50° C
Maximum daily average ambient air temperature	35° C	40° C
minimum ambient air temperature	-5° C	-30° C
maximum temperature attainable by an object exposed to the sun	60 ° C	60 ° C
maximum yearly weighted average ambient temperature	32° C	32° C
maximum relative humidity	100%	100%
average number of thunder storm days per annum (isokeraunic level)	70	70

average number of rainy days per annum	120	120
average annual rainfall	1500 mm	1500 mm
maximum wind pressure	260Kg/m <sup>2</sup>	260Kg/m <sup>2</sup>

\* HP, J&K, Uttarakhand, Sikkim, Assam, Meghalaya, Manipur, Nagaland, Tripura and Mizoram will be considered as Hilly Area.

Environmentally, the region where the equipment will be installed includes coastal areas, subject to high relative humidity, which can give rise to condensation. Onshore winds will frequently be salt laden. On occasions, the combination of salt and condensation may create pollution conditions for outdoor insulators. Therefore, outdoor material and equipment shall be designed and protected for use in exposed, heavily polluted, salty, corrosive, tropical and humid coastal atmosphere.

#### 4 **SYSTEM CONDITIONS**

The equipment shall be suitable for installation in supply systems of the following characteristics.

Frequency		50Hz ± 5%
Nominal system voltages		33 KV 11 KV
Maximum system voltages	33KV System 11KV System	36.3 KV 12 KV
Nominal short circuit level (Based on apparent power)	33KV System 11KV System	31.5KA 13.1KA
Insulation levels : 1.2/50 μ sec impulse withstand voltage	33KV System 11KV System	170KV (peak) 75 KV (peak)
Power frequency one minute withstand (wet and dry) voltage	33KV System 11KV System	70KV (rms) 28KV (rms)
Neutral earthing arrangements	11 KV System	Solidly earthed

#### 5 **CODES & STANDARDS**

5.1 (i) The design, material, fabrication, manufacture, inspection, testing before dispatch and performance of power transformers at sites shall comply with all currently applicable statutory regulations and safety codes in the locality where the equipment will be installed. The equipment shall also conform to the latest applicable standards and codes of practice. Nothing in this specification shall be construed to relieve the contractor of this responsibility.

5.2 The equipment and materials covered by this specification shall conform to the latest applicable provision of the following standards.

IS:5	Colour for ready mixed paints
IS:325	Three Phase Induction Motors
IS:335	New insulating oil for transformers, switch gears
IS:1271	Classification of insulating materials for electrical

	machinery and apparatus in relation to their stability in services
IS:2026(Part I to IV)	Power Transformer
IS:2071	Method of high voltage testing
IS:2099	High voltage porcelain bushings
IS:2147	Degree of protection
IS:2705	Current Transformers
IS:3202	Code of practice for climate proofing of electrical equipment
IS:3347	Dimensions for porcelain Transformer Bushings
IS:3637	Gas operated relays
IS:3639	Fittings and accessories for power Transformers
IS:5561	Electric Power Connectors
IS:6600/BS:CP"10:0	Guide for loading of oil immersed Transformers
IS:10028	Code of practice for selection, installation and maintenance of transformers, Part I, II and III
C.B.I.P. Publication	Manual on Transformers

If the standard is not quoted for any item, it shall be presumed that the latest version of Indian Standard shall be applicable to that item.

The equipment complying with the internationally accepted standards, may also be considered if they ensure performance superior to the Indian Standards.

### 5.3 DRAWINGS

- a) The contractor shall furnish, within fifteen days after issuing of Letter of Award. Six copies each of the following drawings/documents incorporating the transformer rating for approval.
  - i) Detailed overall general arrangement drawings showing front and side elevations and plan of the transformer and all accessories including radiators and external features with details of dimensions, spacing of wheel sineither direction of motion, net weights and shipping weights, crane lift for un-tanking, size of lugs and eyes, bushing lifting dimensions, clearances between HV and L.V terminals and ground, quantity of insulating oil etc.
  - ii) Assembly drawings of core and winging and weight of main components /parts
  - iii) Foundation plan showing loading on each wheel and jacking points with respect to centre line of transformer.
  - iv) GA drawings detail of bushing and terminal connectors.
  - v) Name plate drawing with terminal marking and connection diagrams.
  - vi) Wheel locking arrangement drawing.
  - vii) Transportation dimensions drawings.

- Viii) Magnetization characteristic curves of PS class neutral and phase side current transformers, if applicable.
  - ix) Interconnection diagrams.
  - x) Overfluxing withstand time characteristic of transformer.
  - xi) GA drawing of marshalling box.
  - xii) Control scheme/wiring diagram of marshalling box.
  - xiii) Technical leaflet of major components and fittings.
  - xiv) As built drawings of schematics, wiring diagram etc.
  - xv) Setting of oil temperature indicator, winding temperature indicator.
  - xvi) Completed technical data sheets.
  - xvii) Details including write-up of tap changing gear.
  - xviii) HV & LV bushing.
  - xix) Bushing Assembly.
  - xx) Bi-metallic connector suitable for connection to 100 mm<sup>2</sup> to 232 mm<sup>2</sup> AAAC Conductor.
  - xxi) GA of LV cable Box.
  - xxii) Radiator type assembly.
- b) All drawings, documents, technical data sheets and test certificates, results calculations shall be furnished.
- 5.4 Any approval given to the detailed drawings by the Employer's shall not relieve the contractor of the responsibility for correctness of the drawing and in the manufacture of the equipment. The approval given by the employer shall be general with overall responsibility with contractor.

## **6. GENERAL CONSTRUCTIONAL FEATURES**

- 6.1 All material used shall be of best quality and of the class most suitable for working under the conditions specified and shall withstand the variations of temperature and atmospheric conditions without distortion or deterioration or the setting up of undue stresses which may impair suitability of the various parts for the work which they have to perform.
- 6.2 Similar parts particularly removable ones shall be interchangeable.
- 6.3 Pipes and pipe fittings, screws, studs, nuts and bolts used for external connections shall be as per

therelevant standards.Steel boltsand nuts exposed toatmosphereshallbe galvanized.

- 6.4 Nuts,boltsandpinsusedinsidethetransformersandtapchangercompartmentsshallbeprovided with lock washer or locknuts.
- 6.5 Exposed partsshallnothave pocketswherewatercan collect.
- 6.6 Internaldesignoftransformershall ensurethat air is nottrappedinanylocation.
- 6.7 Materialincontactwithoilshallbesuchasnottocontributetotheformationofacidinoil.Surfaceincontactwithoil shall not be galvanizedor cadmium plated
- 6.8 Labels,indeliblymarked,shallbeprovidedforallidentifiableaccessorieslikeRelays,switchescurrent transformersetc.Alllabel plates shallbe ofin corrodiblematerial.
- 6.9 Allinternalconnectionsandfasteningsshallbecapableofoperatingunderoverloadsandover-excitation,allowedas perspecifiedstands withoutinjury.
- 6.10 Transformerandaccessoriesshallbe designedto facilitateproperoperation,inspection,maintenanceandrepairs.
- 6.11 Nopatching,plugging,shimmingorothersuchmeansofovercomingdefects,discrepanciesorerrorswillbe accepted.
- 6.12 SchematicDrawingofthewiring,includingexternalcablesshallbeputundertheprospanesheeton the inside doorof thetransformermarshalling box.

**6.13 Painting**

- 6.13.1 Allpaintsshallbe appliedinaccordancewith the paintmanufacturer'srecommendations. Particularattentionshall be paid to the following:
  - a) Proper storage to avoid exposureaswellas extremesoftemperature.
  - b) Surface preparationpriorto painting.
  - c) Mixingandthinning
  - d) Application ofpaints and therecommendedlimit ontimeintervals between coats.
  - e) Shelflifeforstorage.
- 6.13.1.1 Allpaints,whenappliedinnormalfullcoat,shallbefreefromruns,sags,wrinkles,patchiness,brushmarkso rother defects.
- 6.13.1.2 Allprimersshallbewellmarkedintotheshell,particularlyinareaswhererepaintingisevident,andthefirstprimingcoatshallbeappliedassoonaspossibleaftercleaning.Thepaintshallbeappliedbyairlessprayaccordingtothemanufacturer'srecommendations.However,whereverairlesspray isnot possible, conventional spray be used with priorapproval of Employer.
- 6.13.1.3 Thesuppliershall,priortopaintingprotectnameplates,letteringgauges,sightglasses,lightfittingsandsimilar such items.

### 6.13.2 **Cleaning and Surface Preparation**

6.13.2.1 After all machining, forming and welding has been completed, all steel work surfaces shall be thoroughly cleaned of rust, scale, weldingslag or spatter and other contamination prior to any painting.

6.13.2.2 Steel surfaces shall be prepared by Sand/Shot blast cleaning or Chemical cleaning by Seven tank process including Phosphate to the appropriate quality.

6.13.2.3 The pressure and Volume of the compressed air supply for the blast cleaning shall meet the work requirements and shall be sufficiently free from all water contamination prior to any painting. 6.13.2.4 Chipping, scraping and steel wire brushing using manual or power driven tools cannot remove firmly adherent mill-scale and shall only be used where blast cleaning is impractical.

#### 6.13.3

Protective Coating As soon as all items have been cleaned and within four hours of the subsequent drying, they shall be given suitable anticorrosion protection.

### 6.13.4 **Paint Material**

Following are the type of paints that may be suitably used for the items to be painted at shop and supply of matching paint to site:

- i) Heat resistant paint (Hot oil proof) for inside surface.
- ii) For external surfaces one coat of Thermo Setting Paint or 2 coats of Zinc chromate followed by 2 coat of POLYURETHANE. The color of the finishing coats shall be dark admiral grey conforming to No. 632 or IS 5:1961.

### 6.13.5 **Painting Procedure**

6.13.5.1 All paintings shall be carried out in conformity with both specifications and with the paint manufacturer's recommendations. All paints in any one particular system. Whether shop or site applied, shall originate from one paint manufacturer.

6.13.5.2 Particular attention shall be paid to the manufacturer's instructions on storage, mixing, thinning and pot life. The paint shall only be applied in the manner detailed by the manufacturer e.g. brush, roller, conventional or airless spray and shall be applied under the manufacturer's recommended conditions. Minimum and maximum time intervals between coats shall be closely followed.

6.13.5.3 All prepared steel surfaces should be primed before visible rusting occurs or within 4 hours whichever is sooner. Chemical treated steel surfaces shall be primed as soon as the surface is dry and while the surface is warm.

6.13.5.4 Where the quality of film is impaired by excess film thickness, (wrinkling, mud cracking or general softness) the suppliers shall remove the unsatisfactory paint coatings and apply another. As a general rule, dry film thickness should not exceed the specified minimum dry film thickness by more than 25%. In all instances, where two or more coats of the same paint are specified, such coatings may or may not be of contrasting colors.

6.13.5.5 Paint applied to items that are not to be painted, shall be removed at supplier's expense, leaving the surface clean, un-stained and undamaged.

### 6.13.6 **Damage to Paints Work**

6.13.6.1 Any damage occurring to any part of the painting scheme shall be made good to the same standard of corrosion protection and appearance as that originally employed.

6.13.6.2 Any damaged paintwork shall be made as follows:

- a) The damaged area, together with an area extending 25mm around its boundary, shall be cleaned down to bare metal.
- b) A priming coat shall immediately be applied, followed by a full paint finish equal to that originally applied and extending 50mm around the perimeter of the originally damaged.

6.13.6.3 The repainted surfaces shall present a smooth surface. This shall be obtained by carefully chamfering the painted edges before & after priming.

**6.13.7 Dry Film Thickness**

6.13.7.1 To the maximum extent practicable, the coats shall be applied as a continuous film of uniform thickness and free of pores. Over-spray, skips, runs, sags and drips should be avoided. The different coats may or may not be same color.

6.13.7.2 Each coat of paint shall be allowed to harden before the next is applied as per manufacturer's recommendations.

6.13.7.3 Particular attention must be paid to full film thickness at edges.

6.13.7.4 The requirement for the dry film thickness (DFT) of paint and the material to be used shall be as given below:

Sl.No	Paint Type	Area to be painted	No of Coats	Total Dry film thickness (Min)
1	Liquid paint			
	a) Zinc Chromate (Primer)	Outside	02	45micron
	b) POLYURETHANE Paint (Finish Coat)	Outside	02	35micron
	c) Hot Oil paint	inside	01	35micron

**7.1 DETAILED DESCRIPTION**

**7.2 Tank**

7.2.1 The transformer tank and covers shall be fabricated from high grade low carbon plate steel of tested quality. The tank and covers shall be of welded construction.

7.2.2 Tank shall be designed to permit lifting by crane or jack of the complete transformer assembly fitted with oil. Suitable lugs and bosses shall be provided for this purpose.

7.2.3 All breams, flanges, lifting lugs, braces and permanent parts attached to the tank shall be welded and where practicable, they shall be double welded.

7.2.4 The main tank body of the transformer, excluding tap changing compartments and radiators, shall be



capable of withstanding pressure of 760 mm of Hg.

- 7.2.5 Inspection hole(s) with welded flange(s) and bolted cover(s) shall be provided on the tank cover. The inspection hole(s) shall be of sufficient size to afford easy access to the lower ends of the bushings, terminal setc.
- 7.2.6 Gasket of nitrile rubber or equivalent shall be used to ensure perfect oil tightness. All gaskets shall be closed design (without open ends) and shall be of one piece only. Rubber gaskets used for flange type connections of the various oil compartments, shall be laid in grooves or ring groove equivalent sections on bolt sides of the gasket, throughout their total length. Care shall be taken to secure uniformly distributed mechanical strength over the gaskets and retain throughout the total length. Gaskets of neoprene and/or any kind of impregnated/bonded core or cork only which can easily be damaged by overpressing are not acceptable. Use of hemp gasket material is also not acceptable.
- 7.2.7 Suitable guides shall be provided for positioning the various parts during assemble or dismantling. Adequate spaces shall be provided between the cores and windings and the bottom of the tank for collection of any sediment.

### 7.3 Tank Cover

The transformer top shall be provided with a detachable tank cover with bolted flanged gasket joint. Lifting lugs shall be provided for removing the cover. The surface of the cover shall be suitable sloped so that it does not retain rain water.

### 7.4 UNDERCARRIAGE

- 7.4.1 The transformer tank filled with oil shall be supported on steel structure with detachable plain rollers. Suitable channels for movement of roller with transformer shall be space accordingly, rollers wheels shall be provided with suitable rollers bearings, which will resist rust and corrosion and shall be equipped with fittings for lubrication.

### 7.5 CORE

- 7.5.1 Each lamination shall be insulated such that it will not deteriorate due to mechanical pressure and the action of hot transformer oil.
- 7.5.2 The core shall be constructed either from high grade, non-aging Cold Rolled Grain Oriented (CRGO) silicon steel laminations conforming to HIB grade with lamination thickness not more than 0.23 mm to 0.27 mm or better (Quoted grade and types shall be used). The maximum flux density in any part of the cores and yoke at normal voltage and frequency shall not be more than 1.69 Tesla. The Bidder shall provide saturation curve of the core material, proposed to be used. Laminations of different grade(s) and different thickness(s) are not allowed to be used in any manner or under any circumstances.

CRGO steel for core shall be purchased only from the approved vendors, list of which is available at <http://apps.powergridindia.com/ims/ComponentList/Power-former%20upto%20420%20kV-CM%20List.pdf>

- 7.5.3 The bidder should offer the core for inspection starting from the destination port to enable Employer for deputing inspecting officers for detail verification as given below and approval by the Employer during the manufacturing stage. Bidder's call notice for the purposes should be accompanied with the following documents applicable as a proof towards use of prime core material: The core coils, if found suitable, are to be sealed with proper seals which shall be opened in presence of the inspecting officers during core-cutting at the manufacturer's or its sub-vendor's premises as per approved design drawing.
- Purchase Order No. & Date.
  - Invoice of the supplier
  - Mill test certificate

- d) Packing list
- e) Biloflading
- f) Bilof entry certificate to customs

Core material shall be directly procured either from the manufacturer or through their accredited marketing organization of repute, but not through any agent.

Please refer to "**Check-list for Inspection of Prime quality CRGO for Transformers**" attached at Annexure-A. It is mandatory to follow the procedure given in this Annexure.

- 7.5.4 The lamination shall be free of all burrs and sharp projections. Each sheet shall have an insulating coating resistant to the action of hot oil.
- 7.5.5 The insulation structure for the core to bolts and core to clamp plates, shall be such as to withstand 2000 V DC voltage for one minute.
- 7.5.6 The completed core and coil shall be so assembled that the axis and the plane of the outer surface of the core assembly shall not deviate from the vertical plane by more than 25mm.
- 7.5.7 All steel sections used for supporting the core shall be thoroughly shot or sand blasted, after cutting, drilling and welding.
- 7.5.8 The finally assembled core with all the clamping structures shall be free from deformation and shall not vibrate during operation.
- 7.5.9 The core clamping structures shall be designed to minimize eddy current loss.
- 7.5.10 The framework and clamping arrangements shall be securely earthed.
- 7.5.11 The core shall be carefully assembled and rigidly clamped to ensure adequate mechanical strength.
- 7.5.12 Oil ducts shall be provided, where necessary, to ensure adequate cooling inside the core. The welding structure and major insulation shall not obstruct the free flow of oil through such ducts.
- 7.5.13 The design of magnetic circuit shall be such as to avoid static discharges, development of short circuit paths within itself to the earth clamping structure and production of flux component at right angle to the plane of the lamination, which may cause local heating. The supporting framework of the core shall be so designed as to avoid the presence of pockets, which would prevent complete emptying of the tank through the drain valve or cause trapping of air during filling.
- 7.5.14 The construction is to be of boltless core type. The core shall be provided with lugs suitable for lifting the complete core and coil assembly. The core and coil assembly shall be so fixed in the tank that shifting will not occur during transport or short circuits.
- 7.5.15 The temperature gradient between core & surrounding oil shall be maintained less than 20 deg. Centigrade. The manufacturer shall demonstrate this either through test (procurement to be mutually agreed) or by calculation.

## 7.6 **INTERNAL EARTHING**

- 7.6.1 All internal metal parts of the transformer, with the exception of individual laminations and their individual clamping plates shall be earthed.
- 7.6.2 The top clamping structures shall be connected to the tank by a copper strap. The bottom clamping structures shall be earthed by one or more of the following methods:
- a) By connection through vertical tie-rod to the top structure.
  - b) By direct metal to metal contact with the tank base.
  - c) By a connection to the structure on the same side of the core as the main earth connection to the tank.
- 7.6.3 The magnetic circuit shall be connected to the clamping structure at one point only and this shall be brought out of the top cover of the transformer tank through a suitably rated insulator. A disconnecting link shall be provided on transformer tank to facilitate disconnections from ground for IR measurement purpose.
- 7.6.4 Coil clamping rings of metal at earth potential shall be connected to the adjacent core clamping structure on the same side as the main earth connections.

## 7.7 WINDING

- 7.7.1 Windings shall be subjected to a shrinking and seasoning process, so that no further shrinkage occurs during service. Adjustable devices shall be provided for taking up possible shrinkage in service. 7.6.2 Allow voltage windings for use in the circular coil concentric windings shall be wound on a performed insulating cylinder for mechanical protection of the winding in handling and placing around the core.
- 7.7.2 Windings shall not contain sharp bends which might damage the insulation or produce high dielectric stresses. No strip conductor wound on edges shall have width exceeding six times the thickness. The conductor shall be of electrolytic grade copper free from scales and burrs. The conductor insulation shall be made from high-density (at least 0.75 gm/cc) paper having high mechanical strength. The barrier insulation including space resin shall be made from high-density pre-compressed pressboard (1.1 gm/cc minimum for load bearing and 1 to 1.3 gm/cc minimum for non-load bearing) to minimize dimensional changes.
- 7.7.3 Materials used in the insulation and assembly of the windings shall be insoluble, non-catalytic and chemically inactive in the hot transformer oil and shall not soften or be otherwise affected under the operating conditions.
- 7.7.4 Winding and connections shall be braced to withstand shocks during transport or short circuit.
- 7.7.5 Permanent current carrying joints in the windings and leads shall be welded or brazed. Clamping bolts for current carrying parts inside oil shall be made of oil resistant material which shall not be affected by acidity in the oil. Steel bolts, if used, shall be suitably treated.
- 7.7.6 Terminals of all windings shall be brought out of the tank through bushings for external connections.
- 7.6.6.1 The completed core and coil assemblies shall be dried in vacuum at not more than 0.5 mm of mercury absolute pressure and shall be immediately impregnated with oil after the drying process to ensure the elimination of air and moisture within the insulation. Vacuum may be applied in either vacuum over or in the transformer tank.
- 7.6.6.2 The windings shall be so designed that all coil assemblies of identical voltage ratings shall be interchangeable and field repairs to the winding can be made readily without special equipment. The coils shall have high dielectric strength.
- 7.6.6.3 Coils shall be made of continuous smooth high grade electrolytic copper conductor, shaped and braced to

provide for expansion and contraction due to temperature changes.

- 7.6.6.4 Adequate barriers shall be provided between coils and core and between high and low voltage coil. End turn shall have additional protection against abnormal line disturbances.
- 7.6.6.5 The insulation of windings shall be designed to withstand voltage stress arising from surge in transmission lines due to atmospheric or transient conditions caused by switching etc.
- 7.6.6.6 Tappings shall not be brought out from inside the coil or from intermediate turns and shall be so arranged as to preserve as far as possible magnetic balance of transformer at all voltage ratios.
- 7.6.6.7 Magnitude of impulse surge transferred from HV to LV windings by electromagnetic induction and capacitance coupling shall be limited to BIL of LV winding.

## 7.7 INSULATING OIL

- 7.7.1 The insulating oil for the transformers shall be of EHV grade, generally conforming to IS: 335. No inhibitors shall be used in the oil.
- 7.7.2 The quantity of oil required for the first filling of the transformer and its full specifications shall be stated in the bid. Transformer shall be supplied complete with all fittings, accessories and new transformer oil required for first filling plus 10% extra oil. The extra quantity of oil shall be supplied in non-returnable drums along with the oil required for the radiator banks.
- 7.7.3 The design and materials used in the construction of the transformers shall be such as to reduce the risk of the development of acidity in the oil.
- 7.7.4 The oil parameters shall be as per Table-1 of IS 335.

## 7.8 VALVES

- i) Valves shall be of forged carbon steel up to 50 mm size and of gun metal or of cast iron bodies with gun metal fittings for sizes above 50 mm. They shall be of full way type with screwed ends and shall be opened by turning counter clockwise when facing the hand wheel. There shall be no oil leakage when the valves are in closed position.  
  
Each valve shall be provided with an indicator to show the open and closed positions and shall be provided with facility for padlocking in either open or closed position. All screwed valves shall be furnished with pipe plugs for protection. Padlocks with duplicate keys shall be supplied along with the valves.
- ii) All valves except screwed valves shall be provided with flanges having machined faced drilled to suit the applicable requirements. Oil tight blanking plates shall be provided for each connection for use when any radiator is detached and for all valves opening to atmosphere. If any special radiator valve tools are required the contractor shall supply the same.
- iii) Each transformer shall be provided with following valves on the tank:
  - a) Drain valves so located as to completely drain the tank & to be provided with locking arrangement.
  - b) Two filter valves on diagonally opposite corners of 50 mm size & to be provided with locking arrangement.
  - c) Oil sampling valves not less than 8 mm at top and bottom of main tank & to be provided with locking

arrangement.

- d) One 15mm air release plug.
- e) Valves between radiators and tank. Drain and filter valves shall be suitable for applying vacuum as specified in the specifications.

## 7.9 ACCESSORIES

### 7.9.1 Bushing

- i) All porcelain used in bushings shall be homogeneous, non-porous, uniformly glazed to brown colour and free from blisters, burns and other defects.
- ii) Stress due to expansion and contraction in any part of the bushing shall not lead to deterioration.
- iii) Bushing shall be designed and tested to comply with the applicable standards.
- iv) Bushing rated for 400A and above shall have non-ferrous flanges and hardware.
- v) Fittings made of steel or malleable iron shall be galvanized.
- vi) Bushing shall be so located on the transformer that full flashover strength will be utilized. Minimum clearances as required for the BIL shall be realized between live parts and live parts to earthed structures.
- vii) All applicable routine and type test certificates of the bushings shall be furnished for approval.
- viii) Bushing shall be supplied with bi-metallic terminal connector/clamp/washers suitable for fixing to bushing terminal and the Employer's specified conductors. The connector/clamp shall be rated to carry the bushing rated current without exceeding a temperature rise of 550°C over an ambient of 50°C. The connector/clamp shall be designed to be corona free at the maximum rated line to ground voltage.
- ix) Bushing of identical voltage ratings shall be interchangeable.
- x) The insulation class of high voltage neutral bushing shall be properly coordinated with the insulation class of the neutral of the low voltage winding.
- xi) Each bushing shall be so coordinated with the transformer insulation that a full flashover will occur outside the tank.
- xii) The extended bushing busbar shall be used for termination of 11KV cables. LV busings shall be housed in completely sealed metallic enclosure.
- xiii) Sheet steel, weather, vermin and dust proof cable box fitted with required glands, locks, glass door, terminal board, heater with switch, illumination lamp with switch, water-tight hinged and padlocked door of a suitable construction shall be provided with each transformer to accommodate 11KV cables etc. The box shall have slopping roof and the interior and exterior paintings shall be in accordance with the specification. Padlock along with duplicate keys shall be supplied for marshaling box. The degree of protection shall be IP-55 or better. To prevent internal condensation, a metal clad heater with thermostat shall be provided. The heaters shall be controlled by a MCB of suitable rating mounted in the box. The ventilation louvers, suitably padded with felt, shall also be provided. The louvers shall be provided with suitable felt pad stop preventing ingress of dust. All incoming cables shall enter the kiosk from the bottom and the minimum 4mm thick, non-

magnetic gland plates shall not be less than 600mm from the base of the box. The gland plate and associated compartments shall be sealed in suitable manner to prevent the ingress of moisture from the cable trench **–for those transformers which are used in partly indoors substation**, *If required as per BOQ, a cable box for LV bushings shall be provided.*

### 7.9.2 Protection & Measuring Devices

#### i) Oil Conservator Tank

- a) The Conservator tank shall have adequate capacity between highest and lowest visible level to meet the requirement of expansion of the total cold oil volume in the transformer and cooling equipment.
- b) The conservator tank shall be bolted into position so that it can be removed for cleaning purposes.
- c) The conservator shall be fitted with magnetic oil level gauge with low level electrically insulated alarm contact.
- d) Plain conservator fitted with silica gel breather.

#### ii) Pressure Relief Device.

The pressure relief device provided shall be of sufficient size for rapid release of any pressure that may be generated in the tank and which may result in damage of the equipment. The devices shall operate at a static pressure of less than the hydraulic test pressure of transformer tank. Its shall be mounted directly on the tank. A pair of electrically insulated contacts shall be provided for alarm and tripping.

#### iii) Buchholz Relay

A double float type Buchholz relay shall be provided. Any gas evolved in the transformer shall collect in this relay. The relay shall be provided with a test cocks suitable for a flexible pipe connection for checking its operation. A copper tube shall be connected from the gas collector to a valve located about 1200mm above ground level to facilitate sampling with the transformer in service. The devices shall be provided with two electrically independent potential free contacts, one for alarm on gas accumulation and the other for tripping on sudden rise of pressure.

#### iv) Temperature Indicator

##### a) Oil Temperature Indicator (OTI)

The transformers shall be provided with a micro switch contact type thermometer with 150mm dial for top oil temperature indication. The thermometers shall have adjustable, electrically independent potential free alarm and trip contacts. Maximum reading pointer and resetting devices shall be mounted in the local control panel. A temperature sensing element suitably located in a pocket on top oil shall be furnished. This shall be connected to the OTI by means of capillary tubing. Accuracy class of OTI shall be  $\pm 1\%$  or better. One No electrical contact capable of operating at 5A ac at 230 volts supply.

##### b) Winding Temperature Indicator (WTI)

A device for measuring the hot spot temperature of the windings shall be provided. It shall comprise the following.

- i) Temperature sensing element.
- ii) Image Coil.
- iii) Microswitch contacts.
- iv) Auxiliary CTS, If required to match the image coil, shall be furnished and mounted in the local control panel.
- v) 150 mm dial local indicating instrument with maximum reading pointer mounted in local panel and with adjustable electrically independent ungrounded contacts, besides that required for control of cooling equipment, one for high winding temperature alarm and on for trip.
- vi) Two number electrical contact each capable of operating at 5A ac at 230 Volt supply.

### 7.9.3 Oil Preservation Equipment

#### 7.9.3.1 Oil Sealing

The oil preservation shall be diaphragm type oil sealing in conservator to prevent oxidation and contamination of oil due to contact with atmospheric moisture.

The conservator shall be fitted with a dehydrating filter breather. It shall be so designed that.

- i) Passage of air is through a dust filter & Silicagel.
- ii) Silicagel is isolate from atmosphere by an oil seal.
- iii) Moisture absorption indicated by a change in colour of the crystal of the silicagel can be easily observed from a distance.
- iv) Breather is mounted not more than 1400 mm above rail top level.

### 7.10 MARSHALLING BOX

- i) Sheet steel, weather, vermin and dust proof marshaling box fitted with required glands, locks, glass door, terminal Board, heater with switch, illumination lamp with switch, water-tight hinged and padlocked door of a suitable construction shall be provided with each transformer to accommodate temperature indicators, terminal block etc. The box shall have slopping roof and the interior and exterior painting shall be in accordance with the specification. Padlock along with duplicate key shall be supplied for marshaling box. The degree of protection shall be IP-55 or better.
- ii) The schematic diagram of the circuitry inside the marshaling box be prepared and fixed inside the door under a propped sheet.
- iii) The marshaling box shall accommodate the following equipment:
  - a) Temperature indicators.
  - b) Space for accommodating Control & Protection equipment in future for the cooling fan (for ONAF type cooling, maybe provided in future).
  - c) Terminal blocks and gland plates for incoming and outgoing cables.

All the above equipment except (c) shall be mounted on panels and back of panel wirings shall be used for inter-connection. The temperature indicators shall be so mounted that the dials are not more than 1600 mm from the ground level and the door(s) of the compartment(s) shall be provided with glazed window of adequate size. The transformers shall be erected on a plinth which shall be 2.5 feet above ground level.

- iv) To prevent internal condensation, a metal clad heater with thermostat shall be provided. The heaters shall be controlled by a MCB of suitable rating mounted in the box. The ventilation louvers, suitably padded with felt, shall also be provided. The louvers shall be provided with suitable felt pads to prevent ingress of dust.
- v) All incoming cables shall enter the kiosk from the bottom and the gland plates shall not be less than 450 mm from the base of the box. The gland plate and associated compartments shall be sealed in suitable manner to prevent the ingress of moisture from the cable trench.

## **7.11 TAPCHANGER**

### **7.11.1 ON-LOAD TAP-CHANGERS**

- i) The 3.15/5/6.3/8/10/12.5 MVA transformers shall be provided with On-load Taps. Specification of OLTC is attached herewith as Annexure.
- ii) The Transformer with off-load tap changing gear shall have taps ranging from +5% to -15% in 9 equal steps of 2.5% each for Off Load Tap.
- iii) The tap changing switch shall be located in a convenient position so that it can be operated from ground level. The switch handle shall be provided with locking arrangement along with tap position indication, thus enabling the switch to be locked in position.

## **7.12 FITTINGS AND ACCESSORIES**

The following fittings and accessories shall be provided on the transformers:

- i) Conservator with isolating valves, oil filling hole with cap and drain valve. The conservator vessel shall be filled with constant oil pressure diaphragm oil sealing system.
- ii) Magnetic type oil level gauge (150 mm dia) with low oil level alarm contacts.
- iii) Prismatic/toughened glass oil level gauge.
- iv) Silica gel breather with oil seal and connecting pipe complete with first fill of activated silica gel or Alumina mounted at a level of 1300 mm above ground level.
- v) A double float type Buchholz relay with isolating valve. Bleeding pipe and a testing cock, the test cock shall be suitable for flexible (pipe connection for checking its operation). A 5 mm dia. Copper pipe shall be connected from the relay test cock to a valve located at a suitable height above ground level to facilitate sampling of gas with the transformer in service. Interconnection between gas collection box and relay shall also be provided. The devices shall be provided with two electrically independent ungrounded contacts, one for alarm on gas accumulation and the other for tripping on sudden oil surge. These contacts shall be wired up to transformer marshaling box. The relay shall be provided with shut off valve on the conservator side as well as on the tank side.



- vi) Pressure relief devices (including pressure relief valve) and necessary air equalizer connection between his and the conservator with necessary alarm and trip contacts.
- vii) Air release plugs in the top cover.
- viii) Inspection cover, access holes with bolted covers for access to inner ends of bushing etc.
- ix) Winding temperature (hotspot) indicating device for local mounting complete in all respects. Winding temperature indicator shall have two set of contacts to operate at different settings :
  - a) To provide winding temperature high alarm
  - b) To provide temperature too high trip
- x) Dial thermometer with pocket for oil temperature indicator with one set of alarm and one set of trip contacts and maximum reading pointer.
- xi) Lifting eyes or lugs for the top cover, core and coils and for the complete transformer.
- xii) Jacking pads
- xiii) Haulage lugs.
- xiv) Protected type mercury / alcohol in glass thermometer and a pocket to house the same.
- xv) Top and bottom filter valves on diagonally opposite ends with padlocking arrangement on both valves.
- xvi) Top and bottom sampling valves.
- xvii) Drain valve with padlocking arrangement
- xviii) Rating and connection diagram plate.
- xix) Two numbers tank earthing terminals with associated nuts and bolts for connections to Employer's grounding strip.
- xx) Marshaling Box (MB)
- xxi) Shutoff valve on both sides of flexible pipe connections between radiator bank and transformer tank.
- xxii) Cooling Accessories:
  - a) Requisite number of radiators provided with :-
    - One shut off valve on top
    - One shut off valve at bottom
    - Air release device on top

- Drain and sampling device at bottom
- Lifting lugs.

b) Air released device and oil drain plug on oil pipe connectors:

- xxiii) Terminal marking plates for Current Transformer and Main Transformer
- xxiv) On/Off Load Tap changer as per BOQ
- xxv) Oil Preservation Equipment
- xxvi) Oil Temperature indicator
- xxvii) Transformers shall be supplied with all control cable, WTI & OTI, sensing cable, glands, lug set c (complete control).

**Note:**

1. The fittings listed above are indicative and any other fittings which are generally required for satisfactory operation of the transformer are deemed to be included in the quoted price of the transformer.
2. The contacts of various devices required for alarm and trip shall be potential free and shall be adequately rated for continuous, making and breaking current duties as specified.

**7.13 CONTROL CONNECTIONS AND INSTRUMENT AND WIRING TERMINAL BOARD AND FUSES**

- i) Normally no fuses shall be used anywhere instead of fuses MCB's (both in AC & DC circuits) shall be used. Only in cases where a MCB cannot replace a fuse due to system requirements, a HRC fuse can be accepted.
- ii) All wiring connections, terminal boards, fuses MCB's and link shall be suitable for tropical atmosphere. Any wiring liable to be in contact with oil shall have oil resisting insulation and the bare ends of stranded wire shall be sweated together to prevent seepage of oil along the wire.
- iii) Panel connections shall be neat and square fixed to the panel. All instruments and panel wirings shall be in PVC or non-rusting metal cleats of the compression type. All wiring to a panel shall be taken from suitable terminal boards.
- iv) Where conduits are used, the run shall be laid with suitable falls, and the lowest part of the run shall be external to the boxes. All conduit runs shall be adequately drained and ventilated. Conduits shall not be run at or below ground level.
- v) When 400 volt connections are taken through junction boxes or marshaling boxes, they shall be adequately screened and 400 volts Danger Notice must be affixed to the outside of the junction boxes or marshaling box. Proper colour code for Red, Yellow, Blue wire shall be followed.
- vi) All box wirings shall be in accordance with relevant ISS. All wirings shall be of stranded copper (48 strands ) of 1100 Volt grade and size not less than 2.5 sq.mm

- vii) All wires on panels and all multi-core cables shall have ferrules, for easy identifications, which bear the same number at both ends, as indicated in the relevant drawing.
- viii) At those points of interconnection between the wiring carried out by separate contractors, where a change of number cannot be avoided double ferrules shall be provided on each wire. The change of numbering shall be shown on the appropriated diagram of the equipment.
- ix) The same ferrule numbers shall not be used on wires in different circuits on the same panels.
- x) Ferrules shall be of white insulating material and shall be provided with glossy finish to prevent the adhesion of dirt. They shall be clearly and durably marked in black and shall not be affected by dampness or oil.
- xi) Stranded wires shall be terminated with tinned Ross Courtney terminals, claw washers or crimped tubular lugs. Separate washers shall be suited to the size of the wire terminated. Wirings shall, in general, be accommodated on the sides of the box and the wires for each circuit shall be separately grouped. Back of panel wiring shall be arranged so that access to the connecting items of relays and other apparatus is not impeded.
- xii) All circuits in which the voltage exceeds 125 volts, shall be kept physically separated from the remaining wiring. The function of each circuit shall be marked on the associated terminal boards.
- xiii) Where apparatus is mounted on panels, all metal cases shall be separately earthed by means of stranded (48 No.) copper wire of strip having a cross section of not less than 2 sq. mm where strip is used, the joints shall be sweated. The copper wires shall have green coloured insulation for earth connections.
- xiv) All wiring diagram for control and relay panel shall preferably be drawn as viewed from the back and shall show the terminal boards arranged as in services.
- xv) Terminal block rows should be spaced adequately not less than 100 mm apart to permit convenient access to external cables and terminations.
- xvi) Terminal blocks shall be placed with respect to the cable gland (at a minimum distance of 200 mm) as to permit satisfactory arrangement of multicore cable tails.
- xvii) Terminal blocks shall have pair of terminals for incoming and outgoing wires. Insulating barriers shall be provided between adjacent connections. The height of the barriers and the spacing between terminals shall be such as to give adequate protection while allowing easy access to terminals. The terminals shall be adequately protected with insulating dust proof covers. No live metal shall be exposed at the back of the terminal boards. CT terminals shall have shorting facilities. The terminals for CT should have provision to insert terminal plugs and with isolating links.
- xviii) All interconnecting wiring, as per the final approved scheme between accessories of transformer and marshaling box is included in the scope of this specification and shall be done by the Transformer supplier.
- xix) The schematic diagram shall be drawn and fixed under a transparent prospane sheet on the inner side of the marshaling box cover.
- xx) To avoid condensation in the Marshaling Box, space heaters shall be provided with an MCB and thermostat.
- xxi) Suitable MV, CFL light shall be provided in the Marshaling Box for lightning purpose.

**7.14 RADIO INTERFERENCE AND NOISE LEVEL**

Transformers shall be designed with particular care to suppress at least the third and fifth harmonic voltage so as to minimize interference with communication circuits. Transformer noise level when energized at normal voltage and frequency shall be as per NEMA stipulations.

## **8 INSPECTION AND TESTING**

- (i) The Contractor shall carry out a comprehensive inspection and testing program during manufacture of the transformer. This is, however, not intended to form a comprehensive program as it is contractor's responsibility to draw up and carry out such a program duly approved by the Employer.
- (ii) Transformer of each rating will be as per pre-type tested design.
- (iii) The pre-shipment checks shall also be carried out by the contractor.
- (iv) The requirements on site tests are as listed in the specifications.
- (v) Certified test report and oscillogram shall be furnished to the Employer Consultants for evaluation as per the schedule of distribution of documents. The Contractor shall also evaluate the test results and rectify the defects in the equipment based on his and the Employer's evaluation of the tests without any extra charge to the Employer. Manufacturer's Test Certificates in respect of all associated auxiliary and ancillary equipments shall be furnished.
- (vi) The bidder shall state in his proposal the testing facilities available at his works. In case full testing facilities are not available, the bidder shall state the method proposed to be adopted so as to ascertain the transformer characteristics corresponding to full capacity.

### **8.1 INSPECTION**

Transformers not manufactured as per Type-Tested design shall be rejected.

#### **i) Tank and Conservator**

- a) Inspection of major weld.
- b) Crack detection of major strength weld seams by dye penetration test.
- c) Check correct dimensions between wheels, demonstrate turning of wheels, through 90° and further dimensional check.
- d) Leakage test of the conservator.

#### **ii) Core**

- a) Sample testing of core materials for checking specific loss, properties, magnetization characteristics and thickness.
- b) Check on the quality of varnish if used on the stampings.
- c) Check on the amount of burrs.
- d) Visual and dimensional check during assembly stage.
- e) Check on completed core for measurement of iron loss, determination of maximum flux density,

- f) Visual and dimensional checks for straightness and roundness of core, thickness of limbs and suitability of clamps.
- g) High voltage DC test (2KV for one minute) between core and clamps.

Please refer to "**Check-list for Inspection of Prime quality CRGO for Transformers**" attached at Annexure-A. It is mandatory to follow the procedure given in this Annexure.

**iii) Insulating Material**

- a) Sample check for physical properties of materials.
- b) Check for dielectric strength
- c) Check for the reaction of hot oil on insulating materials.

**iv) Winding**

- a) Sample check on winding conductor for mechanical and electrical conductivity.
- b) Visual and dimensional checks on conductor for scratches, dent mark etc.
- c) Sample check on insulating paper for PH value, electric strength.
- d) Check for the bonding of the insulating paper with conductor.
- e) Check and ensure that physical condition of all material taken for windings is satisfactory and free of dust.
- f) Check for absence of short circuit between parallel strands.

**v) Checks Before Drying Process**

- a) Check condition of insulation on the conductor and between the windings.
- b) Check insulation distance between high voltage connections, between high voltage connections and earth and other live parts.
- c) Check insulating distances between low voltage connections and earth and other parts.
- d) Insulating test for core earthing.

**vi) Check During Drying Process**

- a) Measurement and recording of temperature and drying time during vacuum treatment.
- b) Check for completeness of drying

**vii) Assembled Transformer**

- a) Check completed transformer against approved outlined drawing, provision for all fittings, finish level etc.
- b) Jacking test on the assembled Transformer.

viii) Oil All standard tests in accordance with IS: 335 shall be carried out on Transformer oil sample before filling in the transformer.

ix) Test Report for bought out

items The contractor shall submit the test reports for all bought out/subcontracted items for approval.

- a) Buchholz relay
- b) Sudden pressure rise relay on Main Tank
- c) Winding temperature indicators (for TX capacity 5 MVA )
- d) Oil temperature indicators
- e) Bushings
- f) Bushing current transformers in neutral (If Provided)
- g) Marshaling box
- h) On/Off Load Tap changer as per BOQ
- i) Any other item required to complete the works.
- j) Porcelain, bushings, bushing current transformers, wherever provided, winding coolers, control devices, insulating oil and other associated equipments shall be tested by the

contractor in accordance with relevant IS. If such requirement is purchased by the contractor on a sub-contract, he shall have them tested to comply with these requirements.

**8.2 FACTORY TESTS**

- i) All standards routine tests in accordance IS:2026 with dielectric tests corresponding as per latest amendments to IS:2026 shall be carried out.
- ii) All auxiliary equipments shall be tested as per the relevant IS. Test certificates shall be submitted for bought out items.
- iii) High voltage withstand tests shall be performed on auxiliary equipment and wiring after complete assembly.
- iv) Following additional routine tests shall also be carried out on each transformer:
  - a) Magnetic Circuit Test Each core shall be tested for 1 minute at 2000 Volt AC
  - b) Oil leakage test on transformer

**8.2.1 Type Test**

**8.2.1.1** The measurements and tests should be carried out in accordance with the standards specified in each case as indicated in the following table if the same tests were not conducted earlier at CPRI or any NABL accredited Laboratory on the transformers of the offered design without any cost implication on employer.

**Table 6: Transformer type tests**

Type Test	Standard
Temperature Rise Test	IEC76/IS2026/IS6600
Impulse Voltage Withstand Test, including Full Waves and Chopped Waves as listed below	IEC76/IS2026
Noise Level Measurement	IEC551

In accordance with IEC76-3 the following sequence of impulses should have been/should be applied;

- One full wave at 50% BIL;
- One full wave at 100% BIL;
- One chopped wave at 50% BIL
- Two chopped waves at 100% BIL and
- Two full waves at 100% BIL.

**8.2.1.2** If the type test report(s) submitted by the bidder do not fulfill the criteria, as stipulated in the technical specification/Bidder's offer, the relevant type test(s) has/have to be conducted by the Bidder at his own cost in CPRI/NABL accredited laboratory in the presence of employer's representative(s) without any financial liability to employer in the event of order placed on him.

**8.2.1.3** The offered transformer must be manufactured as per type tested design. A copy of type test certificate must be submitted by manufacturer to Engineer/Employer. Transformers offered with out type tested however design shall not be accepted. In case manufacturer agrees for type testing of transformers, testing shall be conducted on manufacturer's cost. No claim shall be acceptable toward type testing. The transformer shall be accepted only on acceptance of type testing results by employer.

**8.2.1.4** The suppliers shall furnish calculations in accordance with IS:2026 to demonstrate the Thermal stability of the transformer to withstand Short Circuit forces.

**8.2.1(A) Special Test**

The short circuit test shall be a mandatory test for each design shall be supplied by the manufacturer and no exceptions shall be allowed. The test shall be conducted as per latest standard tabled below:

Short Circuit Test	IEC 76 / IS 2026
--------------------	------------------

**8.2.2 STAGE INSPECTION**

The suppliers shall offer the core, windings and tank of each transformer for inspection by the Employer's representative(s). During stage inspection, all the measurements like diameter, wind ow height, leg Centre, stack width, stack thickness, thickness of lamination etc. for core assembly, conductor size, insulation thickness, I.D., O.D, winding height, major and minor insulation s for both H.V and L.V windings, length, breadth, height and thickness of plates of Transformer tank, the quality of fittings and accessories will be taken/determined. The supplier can offer for final inspection of the transformers subject to clearance of the stage inspection report by the Employer.

**8.2.3 Routine Tests**

Transformer routine tests shall include tests stated in latest issue of IS: 2026 (Part-1). These tests shall also include but shall not be limited to the following :

- (i) Measurement of winding DC resistance.
- (ii) Voltage ratio on each tapping and check of voltage vector relationship.
- (iii) Impedance voltage at all tappings.
- (iv) Magnetic circuit test as per relevant ISS or CBIP manual or latest standard being followed.
- (v) Measurement of Load losses at normal tap and extreme taps.
- (vi) No load losses and no load current at rated voltage and rated frequency, also at 25% to 120 % of rated voltage in steps.
- (vii) Absorption index, insulation resistance for 15 seconds and 60 seconds (R<sub>60</sub>/R<sub>15</sub>) and polarization index, insulation resistance for 10 minutes and one minute (R<sub>10mt</sub>/R<sub>1 mt</sub>).
- (viii) Induced overvoltage withstand test.
- (ix) Separate source voltage withstand test.
- (x) Tan delta measurement and capacitance of each winding to earth (with all other windings earthed) & between all windings connected together to earth.
- (xi) Measurement of zero sequence impedance



- (xii) Tests on On/Off Load Tap changer as per BOQ (fully assembled on transformer) as per IS 2026
- (xiii) Auxiliary circuit tests
- (xiv) Oil BDV tests
- (xv) Measurement of neutral unbalance current which shall not exceed 2% of the full rated current of the transformer.
- (xvi) Magnetic balance test
- (xvii) Leakage test.

Six (6) set of certified test reports and oscillographs shall be submitted for evaluation prior to dispatch of the equipment. The contractor shall also evaluate the test results and shall correct any defect indicated by his and Employer's evaluation of the tests without charge to the Employer.

#### 8.4 TANK TESTS

##### a) Oil leakage Test:

The tank and oil filled compartments shall be tested for oil tightness completely filled with air or oil of viscosity not greater than that of insulating oil conforming to IS:335 at the ambient temperature and applying a pressure equal to the normal pressure plus 35 kN/m<sup>2</sup> measured at the base of the tank. The pressure shall be maintained for a period of not less than 12 hours of oil and one hour for air and during that time no leak shall occur.

##### b) Pressure Test

Where required by the Employer, one transformer tank of each size together with its radiator, conservator vessel and other fittings shall be subjected to a pressure corresponding to twice the normal head of oil or to the normal pressure plus 35 kN/m<sup>2</sup> whichever is lower, measured at the base of the tank and maintained for one hour.

##### c) Vacuum Test

One transformer tank of each size shall be subjected to the vacuum pressure of 60 mm of mercury. The tanks designed for full vacuum shall be tested at an internal pressure of 3.33 kN/m<sup>2</sup> (25 mm of mercury) for one hour. The permanent deflection of flat plates after the vacuum has been released shall not exceed the values specified in C.B.I.P. Manual on Transformers (Revised 1999) without affecting the performance of the transformer.

#### 8.5 PRE-SHIPMENT CHECK AT MANUFACTURER'S WORKS

- i) Check for proper packing and preservation of accessories like radiators, bushings, explosion vent, dehydrating breather, rollers, Buchholz relay, control cubicle connecting pipes and conservator etc.
- ii) Check for proper provision of bracing to arrest the movement of core and winding assembly inside the tank.
- iii) Gas tightness test to conform tightness.

**8.6 INSPECTION AND TESTING AT SITE**

On receipt of transformer at site, shall be performed detailed inspection covering areas right from the receipt of material up to commissioning stage. An indicative program of inspection as envisaged by the Engineer is given below.

**8.6.1 Receipt and Storage Checks**

- i) Check and record condition of each package visible parts of the transformer set for any damage.
- ii) Check and record the gas pressure in the transformer tank as well as in the gas cylinder.
- iii) Visual check of core and coils before filling up with oil and also check condition of core and winding in general.

**8.6.2 Installation Checks**

- i) Inspection and performance testing of accessories like tap changers etc.
- ii) Check choking of the tubes of radiators
- iii) Test on oil sample taken from main tank top and bottom and cooling system. Samples should be taken only after the oil has been allowed to settle for 24 hours.
- iv) Check the whole assembly for tightness, general appearance etc.
- v) Oil leakage tests.

**8.6.3 Pre-Commissioning Tests**

After the transformer is installed, the following pre-commissioning tests and checks shall be done before putting the transformer in service.

- i) Megger Test
- ii) Phase relationship test ( Vector group test)
- iii) Buchholz relay alarm & surge operation test (Physical)
- iv) Ratio test on all taps
- v) Low oil level ( in conservator) alarm
- vi) Temperature Indicators (Physical)
- vii) Marshaling kiosk (Physical)

**8.6.4 The following additional checks shall be made:**

- i) All oil valves are in correct position closed or opened as required
- ii) All air pockets are cleared.

- iii) Thermometer pockets are filled with oil
- iv) Oil is at correct level in the bushing, conservator, diverter switch & tank etc.
- v) Earthing connections are made.
- vi) Bushing arcing horn is set correctly and gap distance is recorded.
- vii) CT polarity and ratio is correct.

#### 8.7 **PERFORMANCE**

The performance of the transformer shall be measured on the following aspects.

- i) The transformer shall be capable of being operated without danger on any tapping at the rated kVA with voltage variations and  $\pm 10\%$  corresponding to the voltage of the tapping
- ii) Radio interference and Noise Level
- iii) The transformer shall be designed with particular attention to the suppression of third and fifth harmonics so as to minimize interference with communication circuits.

#### 8.8 **FAULT CONDITIONS**

- a) The transformer shall be capable of withstanding for two (2) seconds without damage any external short circuit to earth
- b) Transformer shall be capable of withstanding thermal and mechanical stresses conveyed by symmetrical or asymmetrical fault on any winding. This shall be demonstrated through calculation as per IS : 2026.
- c) Transformer shall accept, without injurious heating, combined voltage and frequency fluctuation which produce the 125% overfluxing condition for one minute and 140% for 5 seconds.

#### 8.9 **WITNESSING OF TESTS AND EXCESSIVE LOSSES**

- i) The Employer reserves the right to reject the transformer if losses exceed the maximum specified as per Clause No. 2. SPECIFIC TECHNICAL REQUIREMENTS (STANDARD CONDITIONS), item- 35 of this specification or if temperature rise of oil and winding exceed the values specified at item -26 of the above clause.

#### 9 **LIQUIDATED DAMAGES FOR EXCESSIVE LOSSES**

There is no positive tolerance on the guaranteed losses offered by the bidder. However, the transformer(s) shall be rejected outrightly, if any of the losses i.e. no load loss or load loss or both exceed(s) the guarantee maximum permissible loss figures quoted by the bidder in the Technical Data Schedule with the bid.

#### 10 **SPARE PARTS**

In case the manufacturer goes out of production of spare parts, then he shall make available the drawings of spare parts and specification of materials at no extra cost to the Employer to fabricate or procure spare parts from other sources.

**Mandatory Spare Parts**

The suppliers shall provide the following mandatory spares for each of Transformers supplied

1. H.V.&L.V. Bushing & Studs – Each 2 Nos
2. Bimetallic connector for H.V & L.V. Bushings – Each 2 sets

**10.1 INSTRUCTION MANUAL**

Eight sets of the instruction manuals shall be supplied at least four (4) weeks before the actual dispatch of equipment. The manuals shall be in bound volumes and shall contain all the drawings and information required for erection, operation and maintenance of the transformer. The manuals shall include among other, the following particular:

- a) Marked erection prints identifying the components, parts of the transformer as dispatched with assembly drawings.
- b) Detailed dimensions, assembly and description of all auxiliaries.
- c) Detailed views of the core and winding assembly, winding connections and tapping step changer construction etc. These drawings are required for carrying out overhauling operation at site.
- d) Salient technical particulars of the transformer.
- e) Copies of all final approved drawings.
- f) Detailed O&M instructions with periodical checklists and Performa etc.

**10.2 COMPLETENESS OF EQUIPMENT**

All fittings and accessories, which may not be specifically mentioned in the specification but which are necessary for the satisfactory operation of the transformer, shall be deemed to be included in the specification and shall be furnished by the supplier without extra charges. The equipment shall be complete in all details whether such details are mentioned in the specification or not, without any financial liability to the Employer under any circumstances.

**11.0 COMMISSIONING**

The utility will give a 10 days' notice to the supplier of transformer before commissioning. The manufacturer will depute his representative to supervise the commissioning. In case, the manufacturer fails to depute his representative, the utility will go ahead with the commissioning and under these circumstances, it would be deemed that commissioning is done as per recommendations of manufacturer.

**12.0 GUARANTEE**

The manufacturers of the transformer shall provide a guarantee of 60 months from the date of receipt of transformer at the stores of the Utility. In case the transformer fails within the guarantee period, the supplier will depute his representative within 15 days from date of

intimation by the utility for joint inspection. In case, the failure is due to the reasons attributed to supplier, the transformer will be replaced/repared by the supplier within 2 months from the date of joint inspection.

**Annexure-B**

**Methodologyforcomputingtotalowningcost for  
 Power Transformer**

<b>TOC=IC+(AxWi) +(BxWc) ; Losses in KW</b>		
Where,		
TOC	=	TotalOwningCost
IC	=	Initialcost including taxes of transformer as quoted by the manufacturer
Afactor	=	Cost of no load lossesinRs/KW (A = 334447)
Bfactor	=	Cost of load lossesin Rs/KW (B = 151616)
Wi	=	Noloadlosses quoted by themanufacturerin KW
Wc	=	Load losses quotedby the manufacturer in KW

**ONLOAD TAPCHANGERFOR33/11KV POWERTRANSFORMER**

The tapping range of On Load Tap Changers shall be +5% to -15% in steps of 1.25% each. The number of taps shall be 17. The On Load Tap Changers shall be supplied with RTCC panel and AVR (Automatic Voltage Regulating Relay)

The Continuous current rating of the tap changers shall be based on connected winding rating and shall have liberal and ample margin. Lower rated tap changers connected in parallel are not acceptable.

The on-load tap changing equipment shall have the provision for mechanical and electrical control from a local position and electrical control from a remote position. For local mechanical operation, the operating handle shall be brought outside the tank for operation from floor level with provision to lock the handle in each tap position. Remote electrical operations shall have an AUTO-MANUAL selection at the remote location. When selected AUTO, the tap changing gear shall maintain steady voltage within practical limit on the transformer secondary bus from which the reference shall not respond to transient variation of voltage due to grid disturbance and system fault.

The required voltage relay shall not be sensitive to frequency variation and shall be suitable for sensing voltage from the secondary of potential transformers mounted on the 66KV, 33KV, or 11KV bus.

The tap changers shall be provided with over-current protection in order to prevent the tap-change operation during a short circuit, which would do great stress to the contacts of the diverters switch. The function of protection shall be arranged as follows;

- (i) Whenever overcurrent occurs, the control circuit for commanding OLTC motor operations shall be blocked by the normally closed contacts of the overcurrent relays.
- (ii) If during tap change overcurrent occurs, the OLTC motor circuit shall be blocked through the mechanical cam switch, which is close from the very beginning to the very end of every tap change operation and to the normally open contacts of the overcurrent relays. The stop action of the motor shall be made through the motor brake contactor.

The design of the tap changing equipment shall be such that the mechanism will not stop in any intermediate position; however, if the mechanism through faulty operation does stop in an intermediate position, the full load must be carried by the transformer without injury to the equipment. The mechanical position indicator shall be equipped in the motor drive cubicle. The motor shall be designed to be of step control. In any case the operations shall be of step by step.

The **voltage regulating relay** shall be supplied together with the timer and undervoltage relay. The signal order from the voltage regulating relay to execute the tap changer operation, when the regulating voltage is out of the voltage regulating level shall be designed to be delayed by the adjustable timer. If the control voltage abnormally falls, the movement of the tap changers shall be blocked by the contact of the undervoltage relay, even if the contacts of the voltage regulating relay are working.

The control circuit of the transformers shall be completely designed and provisions shall be made for parallel operation with another transformer.

The following accessories, control and selector switches and other necessary accessories shall be furnished.

Remote tap changer control board

(Placed in the control room)

- Voltmeter
- "AUTO-MANUAL" control switch

- "RAISE-LOWER"controlswitch
- Tappositionindicator
- Tapchangeroperationprogramindicator.

TransformerTapChangerdrivingmechanismcontrolcubicle

- "REMOTE-LOCAL-TEST"selector switch
- "AUTOMATIC-MANUAL" controlswitch
- "RAISE-LOWER" controlswitch
- Tappositionindicator
- Tapchangeroperationprogramindicator
- Voltmeter
- Tapchangeoperationcounter
- Meansformanualoperationwhenpowersupplyislost

**Annexure - A**

**Check-list for Inspection of Prime quality CRGO for Transformers**

During inspection of PRIME CRGO, the following points needs to be checked by the Transformer manufacturer. Utility's inspector shall verify all these points during inspection:-

i) **In case PRIME CRGO cutting is at works of Transformer Manufacturer:**

Review of documents:

Purchase Order (unpriced) to PRIME CRGO supplier/Authorised Agency  
 Manufacturer's test certificate

Invoice of the Supplier

Packing List

Bill of Lading

Bill of Entry Certificate by Customs Deptt.

Reconciliation Statement as per format below  
 Certificate of Origin  
 BIS Certification

**Format for Reconciliation/Traceability records**

Packing List No./date /Quantity of PRIME CRGO received

Name of Manufacturer

Manufacturer test certificate No./date

Serial	Details of	Drawing	Quantity	Commulative	Balance
--------	------------	---------	----------	-------------	---------

No.	Package/Job	Reference	Involved	Quantity Consumed	Stock

(i).1 Inspection of PRIME CRGO Coils:

PRIME CRGO-Manufacturer’s Identification Slip on PRIME CRGO Coils  
 Visual Inspection of PRIME CRGO Coils offered as per packing list ( for verification of coil details as per Test certificate & healthiness of packaging).  
 Unique numbering inside of each sample of PRIME CRGO coil and verification of records to be maintained in the register for consumption of CRGO coil.  
 ISI logo sticker on packed mother coil and ISI logo in Material TC.

2.2. During inspection of PRIME CRGO, surveillance testing of sample shall be carried out for Stacking Factor, Permeability, Specific watt loss at 1.5 Tesla and/or 1.7 Tesla depending on the grade of PRIME CRGO and aging test etc. applicable as per relevant IS/ IEC standard, Tech. Spec., MQP and Transformer manufacturer plant standard.

**Inspection Clearance Report would be issued after this inspection**

3. Inspection of PRIME CRGO laminations: Transformer manufacturer will maintain records for traceability of laminations to prime CRGO coils and burr/bow on laminations shall be measured. Utility can review these records on surveillance basis.

4. Inspection at the time of core building:  
 Visual Inspection of PRIME CRGO laminations. In case of suspected mix-up/ rusting/decoloration, samples may be taken for testing on surveillance basis for tests mentioned in A.2.2 above.

Above tests shall be witnessed by Utility. In case testing facilities are not available at Manufacturer’s work, the sample(s) sealed by Utility to be sent to approved labs for testing.

**Inspection Clearance Report would be issued after this inspection**

**(i) In case PRIME CRGO cutting is at Sub-vendor of Transformer Manufacturer:**

Review of documents:

Purchase Order (unpriced) to PRIME CRGO supplier/ Authorised Agency

Purchase Order (unpriced) to Core Cutter

Manufacturer test certificate

Invoice of the Supplier

Packing List

Bill of Lading

Bill of Entry Certificate by Customs Deptt.

Reconciliation Statement as per format below

Certificate of origin

BIS Certification

**Format for Traceability records as below:-**

Packing List No./date /Quantity of PRIME CRGO received

Name of Manufacturer



Manufacturer test certificate No./date

Serial No.	Name of Customer	Deetails of Package/Job	Drawing Reference	Quantity Invoved	Commulative Quantity Consumed	Balance Stock	Dispatch details

(ii) .1 Inspection of PRIME CRGO Coils:

PRIME CRGO-Manufacturer’s Identification Slip on PRIME CRGO Coils  
 Visual Inspection of PRIME CRGO Coils offered as per packing list ( for verification of coil details as per Test certificate & healthiness of packaging).  
 Unique numbering inside of each sample of PRIME CRGO coil and verification of records to be maintained in the register for consumption of CRGO coil.  
 ISI logo sticker on packed mother coil and ISI logo in Material TC.

2.2. During inspection of PRIME CRGO, surveillance testing of sample shall be carried out for Stacking Factor, Permeability, Specific watt loss at 1.5 Tesla and/or 1.7 Tesla, thickness depending on the grade of PRIME CRGO and aging test etc. applicable as per relevant IS/ IEC standard, Tech. Spec., MQP and Transformer manufacturer plant standard.

**Inspection Clearance Report would be issued after this inspection**

3 Inspection of PRIME CRGO laminations:

Transformer manufacturer representative will inspect laminations and issue their internal Inspection Clearance Report. Inspection will comprise of review of traceability to prime CRGO coils, visual Inspection of PRIME CRGO laminations and record of burr/bow. After clearance given by transformer manufacturer, Utility will issue an Inspection Clearance Report after record review. If so desired by Utility, their representative may also join transformer manufacturer representative during this inspection.

**Inspection Clearance Report would be issued after this inspection**

vi) Inspection at the time of core building:

Visual Inspection of PRIME CRGO laminations. In case of suspected mix-up/rusting/decoloration, samples may be taken for testing on surveillance basis for tests mentioned in B.2.2.

**Inspection Clearance Report would be issued after this inspection**

**NOTE :-**

- a) Transformer Manufacturer to ensure that PRIME CRGO is procured from POWERGRID approved vendors and CRGO manufacturer should have valid BIS Certificate for respective offered Grade.
- 14.1 Transformer Manufacturer should also involve themselves for ensuring the quality of CRGO laminations at their Core Cutter’s works. They should visit the works of their Core cutter and carry out necessary checks.

**a) General**

If a surveillance sample is drawn and sent to TPL (if testing facility not available with the manufacturer), the Transformer manufacturer can continue manufacturing at their own risk and cost pending TPL test report on PRIME CRGO sample drawn. Decision for acceptance of PRIME CRGO shall be based upon report of the sample drawn.

**These checks shall be read in-conjunction with approved Quality Plan, specification as a whole and conditions of contract.**

**Sampling Plan (PRIME CRGO)**

33 / 11 kV	-1 <sup>st</sup> transformer and subsequently at random 10% of Transformers (min. 1) offered for inspection.
DTs and other ratings	-1 <sup>st</sup> transformer and subsequently at random 2% of Transformers (min. 1) offered for inspection.

**NOTE:-** One sample for each lot of CRGO shall be drawn on surveillance basis.

CRGO has to be procured only from POWERGRID approved vendors. List of such vendors is available at the following website. Since the list is dynamic in nature, the site may be checked from time to time to see the list of approved vendors.

<http://apps.powergridindia.com/ims/ComponentList/Power-former%20upto%20420%20kV-CM%20List.pdf>

**Single Phase Oil Immersed Distribution Transformers (Outdoor Type)**

**1 SCOPE:**

- 1.1 This specification covers design, engineering, manufacture, assembly, stage testing, inspection and testing before supply and delivery at site of oil immersed naturally cooled 11kV/240V, 11/√3kV/240V single phase distribution transformers for outdoor use.
- 1.2 The equipments shall conform in all respects to high standards of engineering, design and workmanship and shall be capable of performing in continuous commercial operation in a manner acceptable to the purchaser, who will interpret the meanings of drawings and specifications and shall have the power to reject any work or material which, in his judgment is not in accordance therewith. The offered equipments shall be complete with all components necessary for their effective and trouble free operation. Such components shall be deemed to be within the scope of bidder's supply irrespective of whether these are specifically brought out in this specification and/or the commercial order or not.
- 1.3 The transformer and accessories shall be designed to facilitate operation, inspection, maintenance and repairs. The design shall incorporate every precaution and provision for the safety of equipment as well as staff engaged in the operation and maintenance of equipment.
- 1.4 All outdoor apparatus, including bushing insulators with their mountings, shall be designed so as to avoid any accumulation of water.

**1.5 STANDARD RATINGS**

- 1.5.1 Standard ratings of single phase transformers shall be 5, 10, 16 and 25 kVA.

**2 STANDARDS:**

- 2.1 The materials shall conform in all respects to the relevant Indian Standard, with latest amendments there of unless otherwise specified herein; some of them are listed below.
- 2.2 Material conforming to other internationally accepted standards, which ensure equal or better quality than the standards mentioned above would also be acceptable. In case the bidder who wishes to offer material conforming to the other standards, salient points of difference between the standards adopted and the specific standards shall be clearly brought out in relevant schedule. Four copies of such standards with authentic English translation shall be furnished along with the offer.

**3 SERVICE CONDITIONS:**

Indian Standards	Title	International Standards
IS-2026	Specification for Power Transformers	IEC76
IS1180 (Part-I): 2014	Outdoor Type Oil Immersed Distribution Transformers upto and including 2500kVA, 33kV- Specification	
IS12444	Specification for Copper wire rod	ASTMB-49
IS-335	Specification for Transformer/Mineral Oil	IEC Pub296
IS-5	Specification for colors for ready mixed paints	
IS-104	Ready mixed paint, brushing zinc chromate, priming	
IS-2099	Specification for high voltage porcelain bushing	
IS-649	Testing for steel sheets and strips and magnetic circuits	
IS-3024	Cold rolled grain oriented electrical sheets and strips	
IS -4257	Dimensions for clamping arrangements for bushings	
IS -7421	Specification for Low Voltage bushings	

IS -3347	SpecificationforOutdoorBushings	DIN42531 to 33
IS -5484	SpecificationforAlWirerods	ASTMB- 233
IS -9335	Specification forInsulating Kraft Paper	IEC554
IS -1576	SpecificationforInsulatingPressBoard	IEC641
IS -6600	GuideforloadingofoilImmersedTransformers	IEC76
IS -2362	Determination of watercontent in oil forporcelain bushingoftransformer	
IS -6162	Papercovered Aluminumconductor	
IS -6160	RectangularElectricalconductorforelectricalmachines	
IS -5561	Electricalpowerconnector	
IS -6103	Testingof specificresistanceof electrical insulatingliquids	
IS -6262	Method of testfor powerfactorand dielectric constant of electrical insulating liquids	
IS -6792	Determination of electricalstrength ofinsulating oil	
IS -10028	Installationandmaintenance oftransformers.	

3.1 The distribution transformer to be supplied against this specification shall be suitable for satisfactory continuous operation under the following climatic conditions as per IS 2026 (Part-I).

- i) Location : At various locations in the country
- ii) Max ambient air temperature (°C) : 50
- iii) Minimum ambient air temperature (°C) : -5
- iv) Maximum Averaged daily ambient air temperature (°C) : 40
- v) Maximum Yearly weighted average ambient temperature (°C) : 32
- vi) Maximum altitude above 5000 meters mean sea level (metres) :  

For HP, J&K, Uttarakhand, Sikkim,  
Assam, Meghalaya,  
Manipur, Nagaland, Tripura, Arunachal  
Pradesh and Mizoram

1. The climatic conditions specified above are indicative and can be changed by the user as per requirements.

2. The equipment shall generally be for use in moderately hot and humid tropical climate, conducive to rust and fungus growth unless otherwise specified.

**4 PRINCIPAL PARAMETERS:**

4.1 The Transformer shall be suitable for outdoor installation with single phase, 50 Hz, 11 kV systems in which the neutral is effectively earthed and they should be suitable for service under fluctuations in supply voltage up to plus 12.5% to minus 12.5%.

4.2 The transformers shall conform to the following specific parameters. Rated HV side value (11kV or  $11/\sqrt{3}$  kV) shall be specified in the detailed bill of quantity by purchaser.

Sl.No	ITEM	SPECIFICATION
1.	System voltage(max)	7/ 12kV
2.	Rated voltage HV Rated	$11/\sqrt{3}$ or 11 kV 240 V*
3.	Frequency	50 Hz +/-5%
4.	No.of Phases	Single
5.	Type of cooling	ONAN

**4.3 INSULATION LEVELS**

Voltage(Volts)	Impulse Voltage (kV Peak)	Power Frequency(kV)
433	-	3
11000	75	28
$11000/\sqrt{3}$	60	20

**5 TECHNICAL REQUIREMENTS:**

**5.1 CORE MATERIAL:**

- 5.1.1 Transformer core shall be wound core type construction using new and high quality cold rolled grain oriented (CRGO) steel with heat resistant insulating coating or Amorphous metal.
- 5.1.2 The bidder should offer the core for inspection and approval by the purchaser during manufacturing stage. CRGO steel for core shall be purchased only from the approved vendors, list of which is available at <http://apps.powergridindia.com/ims/ComponentList/Power-former%20upto%20420%20kV-CM%20List.pdf>
- 5.1.3 The transformers shall be suitable for overfluxing (due to combined effect of voltage and frequency) upto 12.5% without injurious heating. The operating flux density shall be such that there is a clear safety margin over the overfluxing limit of 12.5%.
- 5.1.4 No-load currents shall not exceed 3% of full load current and will be measured by energizing the transformer at rated voltage and frequency. Increase of 12.5% of rated voltage shall not increase the no-load current by 6% of full load current.
- 5.1.5 Please refer to "**Check-list for Inspection of Prime quality CRGO for Transformers**" attached at Annexure-A. It is mandatory to follow the procedure given in this Annexure.

**5.2 WINDINGS MATERIALS:**

- 5.2.1 HV and LV windings shall be wound from Aluminum/Copper conductors covered with double paper/enamel. The interlayer insulation shall be of nomex/epoxy resin dotted kraft paper.
- 5.2.2 Proper bonding of interlayer insulation with the conductor shall be ensured. Test for bonding strength to be conducted.
- 5.2.3 The core coil assembly shall be dried in an oven. The type of windings shall be indicated in the tender. Whether LV windings are of conventional type or foil wound shall be indicated.
- 5.2.4 Dimensions of winding coils are very critical. Dimensional tolerances for winding coils shall be within limits as specified in guaranteed technical particulars (GTP).
- 5.2.5 The core coil assembly shall be securely held in position to avoid any movement under short circuit conditions.
- 5.2.6 Joints in the windings shall be avoided. However, if jointing is necessary the joints shall be properly brazed and the resistance of the joints shall be less than that of parent conductor. In case of foil windings, welding of leads to foil can be done within the winding.

**5.3 WINDING CONNECTION AND TERMINAL ARRANGEMENTS:**

- 5.3.1 For 11kV transformers both ends of primary windings shall be brought out through HV bushings. For 11/√3kV transformers, neutral end of the primary HV windings shall be brought out for connecting to 'Neutral' supply wire through 1kV bushings. There shall be provision for connecting 'Neutral' terminal, to local 'Earth' by way of a tinned Copper strip of adequate size and dimension. The secondary windings shall be connected to two LV bushings.

**5.4 OIL:**

- 5.4.1 The insulating oil shall comply with the requirements of IS 335. Use of recycled oil is not acceptable. The specific resistance of the oil shall not be less than  $2.5 \times 10^{12}$  ohm-cm at 27°C when tested as per IS 6103.
- 5.4.2 Oil shall be filtered and tested for breakdown voltage (BDV) and moisture content before filling
- 5.4.3 The design and all materials and processes used in the manufacture of the transformer, shall be such as to reduce to a minimum the risk of the development of acidity in the oil.

**6 LOSSES:**

- 6.1 The bidder shall guarantee individually the no-load loss and load loss without any positive tolerance. The bidder shall also guarantee the total losses (no load + load losses at 75°C) at the 50% of rated load and total losses at 100% of rated shall not exceed the maximum total loss values given in Table-9 of IS 1180 (Part-1):2014.
- 6.2 The maximum allowable losses at rated voltage and rated frequency permitted at 75°C for 11/0.433kV transformers can be chosen by the utility as per **Table-9 for ratings 5, 10, 16, 25kVA as per Energy Efficiency Level-2 specified in IS 1180 (Part-1):2014** for single phase distribution transformers.

6.2 The above losses are maximum allowable and there would not be any positive tolerance. Bids with higher losses than the above specified values would be treated as non-responsive. However, the manufacturer can offer losses less than above stated values. The utility can evaluate offers with losses lower than the maximum allowable losses on total owning cost basis in accordance with methodology given in Annex-I.

**7 PERCENTAGE IMPEDANCE:**

7.1 The percentage impedance of single-phase transformers at 75<sup>0</sup>C for different ratings upto 25kVA shall be as per Table 9 of IS 1180 (Part-1):2014.

**8 TEMPERATURE RISE:**

8.1 The permissible temperature rise shall be as per IS: 1180

8.2 Bids not conforming to the above limits of temperature rise will be treated as non-responsive.

**9 PENALTY FOR NON PERFORMANCE**

9.1 During testing at supplier's works if it is found that the actual measured losses are more than the values quoted by the bidder, the purchaser shall reject the transformer and he shall also have the right to reject the complete lot.

9.2 Purchaser shall reject the entire lot during the test at supplier's works, if the temperature rise exceeds the specified values.

9.3 Purchaser shall reject any transformer during the test at supplier's works, if the impedance values differ from the guaranteed values including tolerance and if they do not meet the requirements of clause 7.1

**10 BUSHINGS:**

10.1 The bushings shall be either porcelain or epoxy type and shall conform to the relevant standards specified. Polymer insulator bushings conforming with relevant IEC can also be used.

10.2 For HV, 12 kV class bushings shall be used and for LV, 1 kV class bushings shall be used.

10.3 The terminal arrangements shall not require separate oil chamber not connected to oil in the main tank.

10.4 The HV bushings shall be fixed to the top cover of the transformer and the LV bushings shall be fixed to transformer on sides and in the same plane.

10.5 The bushing rods and nuts shall be of brass/stainless steel.

10.6 Arcing horns will be provided on HV bushings shall not have arcing horns and 1 clamp for LA shall also be provided for each HT bushing. Supply of LA is not included in DT supplier's scope.

10.7 Bushings shall be marked with manufacturer's name, month and year of manufacture.

**11 BUSHING TERMINALS:**

11.1 HV terminal shall be designed to directly receive ACSR conductor upto 7/2.59mm (without requiring the use of lug) and the LV terminal shall be suitable for directly receiving LT cables (aluminum) ranging from 10 Sqmm to 25 Sqmm both in vertical and horizontal position and the arrangements should be such as to avoid bimetallic corrosion. Terminal connectors must be type tested as per IS 5561.

**12 TANK:**

12.1 The oil volume inside the tank shall be such that even under the extreme operating conditions, the pressure generated inside the tank does not exceed 0.4kg/sq.cm positive or negative. There must be sufficient space from the core to the top cover to take care of oil expansion.

12.2 The tank cover shall have plasticized surface at the top to guard against bird faults. Alternately, suitable insulating shroud shall be provided on the bushing terminals.

12.3 The transformer tank shall be of robust construction round/rectangular in shape and shall be built up of

tested CRCA/Mild Steel Sheet.

- 12.4 The tank shall be capable of withstanding a pressure of  $1 \text{ kg/cm}^2$  (g) and a vacuum of 760 mm of Hg for 30 minutes without any permanent deflection (Air pressure tests shall be conducted as per IS-1180 (Part-I):2014.
- 12.5 The L-seam joint, C-seam joint and all fittings and accessories shall be oiltight and no deflection / bulgings should occur during service.
- 12.6 Manufacturer should carry out the all the welding operations as per the relevant ASME standards and submit a copy of the welding procedure and welder performance qualification certificates to the Purchaser.
- 12.7 The circular bottom plate edges of the tank should be folded upward, for at least 25 mm, to have sufficient overlap with vertical sidewall of the transformer.
- 12.8 The Transformer tank and the top covers shall be designed in such a manner as to leave no external pockets in which water can lodge.
- 12.9 Tank shall have permanent lugs for lifting the transformer body and there shall be facilities for lifting the core coil assembly separately.
- 12.10 The transformers shall be provided with two mounting lugs suitable for fixing the transformer to a single pole by means of 2 bolts of 20 mm diameter as per ANSI C 57.12.20-1988.
- 12.11 Both mounting lugs are made with steel of minimum 5 mm thickness.
- 12.12 Jump proof lips shall be provided for upper mounting lug.
- 12.13 Mounting lug faces shall be in one plane.
- 12.14 Minimum Oil level mark shall be embossed inside the tank (at  $25^{\circ}\text{C}$ ).
- 12.15 The top covers shall be fixed to the tank through clamping only.
- 12.16 HV bushing pockets shall be embossed to top side of the top covers so as to eliminate ingress of moisture and water.
- 12.17 The edges of the top cover shall be formed, so as to cover the top end of the tank and gasket.
- 12.18 Nitrile/polyurethane/neoprene rubber gaskets conforming to latest IS 4253 part-II shall be provided between tank and top cover.
- 12.19 The gaskets shall be continuous i.e. without any joint.

### 13 **TANK SEALING:**

- 13.1 The space on the top of the oil shall be filled with dry air or nitrogen. The nitrogen plus oil volume inside the tank shall be such that even under extreme operating conditions, the pressure generated inside the tank does not exceed  $0.4 \text{ kg/sq.cm}$  positive or negative. The nitrogen shall conform to commercial grade of the relevant standards.

### 14 **SURFACE PREPARATION AND PAINTING:**

#### 14.1 **GENERAL**



14.1.1 All paints, when applied in a normal full coat, shall be free from runs, sags, wrinkles, patchiness, brush marks or other defects.

14.1.2 All primers shall be well marked into the surface, particularly in areas where painting is evident, and the first priming coat shall be applied as soon as possible after cleaning. The paint shall be applied by airless spray according to manufacturer's recommendations.

**14.2 CLEANING AND SURFACE PREPARATION:**

14.2.1 After all machining, forming and welding has been completed, all steel work surfaces shall be thoroughly cleaned of rust, scale, welding slag or spatter and other contamination prior to any painting. Steel surfaces shall be prepared by Shotblast cleaning (IS 9954) to grade Sa. 2.5 of ISO 8501-1 or chemical cleaning including phosphating (IS 3618).

14.2.2 The pressure and volume of the compressed air supply for blast cleaning shall meet the work requirements and shall be sufficiently free from all water contamination to ensure that the cleaning process is not impaired.

14.2.3 Chipping, scraping and steel wire brushing using manual or power driven tools cannot remove firmly adherent mill-scale and shall only be used where shotblast cleaning is impractical. Manufacturer shall indicate such location, for purchaser's information, in his offer.

**14.3 PROTECTIVE COATING:**

As soon as all items have been cleaned and within four hours of the subsequent drying, they shall be given suitable anti-corrosion protection.

**14.4 PAINT MATERIAL:**

Following are the types of paint that may be suitably used for the items to be painted at shop and supply of matching paint to site:

14.4.1 The painting shall be as per Annexure-Paint which is attached herewith.

14.4.2 For external surfaces one coat of Thermo Setting paint or 1 coat of epoxy primer followed by 2 coats of polyurethane base paint. These paints can be either air-drying or stoving.

14.4.3 In case of highly polluted area, chemical atmosphere or at a place very near the sea coast, paint as above with one intermediate coat of high build MIO (Micaceous iron oxide) as an intermediate coat may be used to give a total dry film thickness of 150 to 180 microns.

**14.5 PAINTING PROCEDURE:**

14.5.1 All prepared steel surfaces should be primed before visible rusting occurs or within 4 hours, whichever is sooner. Chemical treated steel surfaces shall be primed as soon as the surface is dry and while the surface is still warm.

14.5.2 Where the quality of film is impaired by excess film thickness (wrinkling, mud cracking or general softness) the suppliers shall remove the unsatisfactory paint coating and apply another. In all instances where two or more coats of the same paint are specified, such coatings may or may not be of contrasting colours.

**14.5.3 DAMAGED PAINTWORK:**

14.5.4 Any damage occurring to any part of a painting scheme shall be made good to the same standard of corrosion protection and appearance as that was originally employed.

14.5.5 Any damaged paint work shall be made good as follows:

14.5.6 The damaged area, together with an area extending 25mm around its boundary, shall be cleaned down to bare metal.

14.5.7 A priming coat shall be immediately applied, followed by a full paint finish equal to that originally applied and extending 50mm around the perimeter of the original damage.

14.5.8 The repainted surface shall present a smooth surface. This shall be obtained by carefully chamfering the painted edges before and after priming.

**14.6 DRY FILM THICKNESS:**

14.6.1 To the maximum extent practicable the coats shall be applied as a continuous film of uniform thickness and free of pores. Overspray, skips, runs, sags and drips should be avoided. The different coats may or may not be of the same colour.

14.6.2 Each coat of paint shall be allowed to harden before the next is applied as per manufacturer's recommendation.

14.6.3 Particular attention must be paid to full film thickness at edges.

**14.7 TESTS:**

- The painted surfaces shall be tested for paint thickness.
- The painted surfaces shall pass the cross-hatch adhesion test and impact test as routine test, Salt spray and Hardness test as per the relevant ASTM standards.

14.8 The paint shade shall be as per Annexure-Paint which is attached herewith.

Note: Supplier shall guarantee the painting performance requirement for a period of not less than 5 years.

**15 RATING AND TERMINAL PLATES:**

15.1 Each transformer shall be provided with a rating plate made of anodized aluminum/stainless steel material securely fixed on the outer body, easily accessible, showing the information given in Fig. 2 of IS 1180 (Part-1):2014 for single phase transformers. The entries on the rating plates shall be indelibly marked by engraving.

15.2 Each transformer shall be provided with a terminal marking plate in accordance with Fig. 5 of IS 1180 (Part-1):2014. The rating and terminal marking plates may be combined into one plate at the option of manufacturer.

15.3 The distribution transformer be marked with the Standard Mark and the use of Standard Mark is governed by the provisions of Bureau of Indian Standards Act, 1986 and the Rules and regulations made thereunder. As per Quality Control Order for Electrical Transformers- 2015, issued by Dept. of Heavy Industries, the Standard / ISI marking on Distribution Transformers is mandatory and the product should be manufactured in compliance with IS 1180 Part-1: (2014).

**16 PRESSURE AND VACUUM REQUIREMENTS:**

16.1 Single phase transformers up to 25kVA, the transformer tank shall be of robust construction, round in shape shall be capable of withstanding a pressure of 100kPa and a vacuum of 760mm of mercury.

**17 FITTINGS:**

17.1 The following standard fittings shall be provided :

17.1.1 Two earthing terminals with earthing symbol.

17.1.2 Lifting lugs for the complete transformer as well as for core and winding assembly.

- 17.1.3 HV side neutral grounding strip (where one of the bushing terminal is connected to earth).
- 17.1.4 Rating and terminal marking plates. (Non detachable type)
- 17.1.5 Pressure relief device or self-ventilating cover
- 17.1.6 HV bushings.
- 17.1.7 LV bushings.
- 17.1.8 HV and LV terminal connectors.
- 17.1.9 Top cover fixing clamps.
- 17.1.10 Mounting lugs - 2 Nos.
- 17.1.11 Bird guard.
- 17.1.12 LV earthing arrangement.
- 17.1.13 Any other fitting required as per IS: 1180 (Part 1)

**18 FASTENERS:**

- 18.1 All bolts, studs, screw threads, pipe threads, bolt heads and nuts shall comply with the appropriate Indian Standards for metric threads, or the technical equivalent.
- 18.2 Bolts or studs shall not be less than 6 mm diameter except when used for small wiring terminals.
- 18.3 All nuts and pins shall be adequately locked.
- 18.4 Wherever possible bolts shall be fitted in such a manner that in the event of failure of locking resulting in the nuts working loose and falling off, the bolt will remain in position.
- 18.5 All bolts/nuts/washers exposed to atmosphere should be as follows.
  - a) Size 12 mm or below – Stainless steel
  - b) Above 12 mm- steel with suitable finish like electro galvanized with passivation or hot dip galvanized.
- 18.6 Each bolt or stud shall project at least one thread but not more than three threads through the nut, except when otherwise approved for terminal board studs or relay systems. If bolts and nuts are replaced so that they are inaccessible by means of ordinary spanners, special spanners shall be provided.
- 18.7 The length of the screwed portion of the bolts shall be such that no screw thread may form part of a shear plane between members.
- 18.8 Taper washers shall be provided where necessary. Protective washers of suitable material shall be provided front and back or the securing screws.

**19 OVERLOAD CAPACITY:**

- 19.1 The transformers shall be suitable for loading as per latest IS 6600.

**20 TESTS:**

All the equipment offered shall be fully type tested by the bidder as per the relevant standards including the additional type tests mentioned at clause 23. The type test must have been conducted on a transformer of same design during the last five years at the time of

bidding. The bidders shall furnish four sets of type test reports along with the offer. **In case, the offered transformer is not type tested, the bidder will conduct the type test as per the relevant standards including the additional type tests at his own cost in CPRI/NABL accredited laboratory in the presence of employers representative(s) without any financial liability to employer in the event of order placed on him.**

- 20.1 Special tests other than type and routine tests, as agreed between purchaser and bidder shall also be carried out as per the relevant standards
- 20.2 The test certificates for all routine and type tests for the transformers and also for the bushings and transformer oil shall be submitted with the bid. However, if the same are not available at the time of bidding, the same may be submitted after order but before commencement of supply.
- 20.3 The procedure for testing shall be in accordance with IS 1180 (Part-1): 2014/2026 as the case may be except for temperature rise.
- 20.4 Before dispatch each of the completely assembled transformers shall be subjected to the routine tests at the manufacturer's works.
- 21 ROUTINE TESTS:**
- 21.1 Ratio, polarity tests.
- 21.2 No load current and losses at service voltage and normal frequency.
- 21.3 Load losses at rated current and normal frequency.
- 21.4 Impedance voltage test.
- 21.5 Resistance of windings cold (at or near the test bed temperature).
- 21.6 Insulation resistance.
- 21.7 Induced over voltage withstand test.
- 21.8 Separate source voltage withstand test. This test will not be applicable for single phase DTs with  $11/\sqrt{3}$  kV as primary voltage.
- 21.9 Oil sample test (one sample per lot) to comply with IS 1866.
- 21.10 Air pressure test on empty tank as per IS 1180

**22 TYPE TESTS TO BE CONDUCTED ON ONE UNIT:**

In addition to the tests mentioned above following tests shall be conducted:

- 22.1 Temperature rise test for determining the maximum temperature rise after continuous full load run. The ambient temperature and time of test should be stated in the test certificate.
- 22.2 Impulse voltage withstand test: As per IS 2026 part-III. Basic insulation level (BIL) for 11 kV shall be 75 kV peak while for  $11/\sqrt{3}$  kV, it will be 60 kVp
- 22.3 Air pressure test: As per IS 1180 (Part-I): 2014.
- 22.4 Short circuit withstand test: Thermal and dynamic ability.

- 22.5 Oil samples (Post short circuit and temperature rise test) - Only DGA & BDV test shall be conducted.
- 22.6 Noise level measurement.
- 22.7 Permissible flux density and overfluxing withstand test.
- 22.8 Type test certificates for the tests carried out on prototype of same specifications shall be submitted along with the bid.
- 22.9 The purchaser may select the transformer for type tests randomly.

**23.10 Short Circuit Test and Impulse Voltage Withstand Test:** The purchaser intends to procure transformers designed and successfully tested for short circuit and impulse test. In case the transformers proposed for supply against the order are not exactly as per the tested design, the suppliers shall be required to carry out the short circuit test and impulse voltage withstand test at their own cost in the presence of the representative of the purchaser.

- 23.11 The supply shall be accepted only after such test is done successfully, as it confirms on successful withstand of short circuit and healthiness of the active parts thereafter on un-tanking after a short circuit test.
- 23.12 Apart from dynamic ability test, the transformers shall also be required to withstand thermal ability test or thermal withstand ability will have to be established by way of calculations.
- 23.13 It may also be noted that the purchaser reserves the right to conduct short circuit test and impulse voltage test in accordance with the IS, afresh on each ordered rating at purchaser's cost, even if the transformer of the same rating and similar design are already tested. This test shall be carried out on a transformer to be selected by the purchaser either at their works when they are offered in a lot for supply or randomly from the supplies already made to purchaser's Stores. The findings and conclusions of these tests shall be binding on the supplier.

**24 TESTS AT SITE:**

- 24.1 The purchaser reserves the right to conduct all tests on transformer after arrival at site and the manufacturer shall guarantee test certificate figures under actual service conditions.

**25 ACCEPTANCE TESTS:**

- 25.1 The transformers shall be subjected to the following routine/acceptance test in the presence of purchaser's representative at the place of manufacture before despatch without any extra charges. The testings shall be carried out in accordance with IS 1180, Part-1 (2014) and IS 2026. Checking of mass, dimensions, fitting and accessories, tank sheet thickness, oil quality, material, finish and workmanship as per GTP/QA plan and contract drawings.
- 25.2 Physical verification of core coil assembly and measurement of flux density of one unit of each rating, in every inspection with reference to short circuit test report.
- 25.3 All tests as specified in clause 22.

**26 INSPECTION:**

- 26.1 In respect of raw materials such as core stampings, winding conductors, insulating paper and oil, suppliers shall use materials manufactured/supplied by standard manufacturers and furnish the manufacturer's test certificate as well as the proof of purchase from the manufacturers (excise gate pass) for information of the purchaser. The bidders shall furnish following documents along with their offer in respect of the raw materials:

- 26.1.1 Invoice of supplier.
- 26.1.2 Mill's certificate.
- 26.1.3 Packing List.
- 26.1.4 Bill of lading.
- 26.1.5 Bill of entry certificate by custom.  
 Please refer to "**Check-list for Inspection of Prime quality CRGO for Transformers**" attached at Annexure-A. It is mandatory to follow the procedure given in this Annexure.
- 26.2 To ensure about the quality of transformers, the inspections shall be carried out by the purchaser's representative at following stages:
- 26.2.1 Online any time during receipt of raw material and manufacture/assembly whenever the purchaser desires.
- 26.2.2 When the raw material is received, and the assembly is in process in the shop floor.
- 26.2.3 At finished stage i.e. transformers are fully assembled and are ready for despatch.
- 26.3 After the main raw materials i.e. core and coil materials and tanks are arranged and transformers are taken for production on shop floor and a few assembly have been completed, the firm shall intimate the purchaser in this regard, so that an officer for carrying out such inspection could be deputed, as far as possible within seven days from the date of intimation. During the stage inspection a few assembled cores shall be dismantled (only in case of CRGO material) to ensure that the CRGO laminations used are of good quality. Further, as and when the transformers are ready for despatch, an offer intimating about the readiness of transformers, for final inspection for carrying out tests as per relevant IS and as in clauses above, shall be sent by the firm along with routine test certificates. The inspections shall normally be arranged by the purchaser at the earliest after receipt of offer for pre-delivery inspection.
- 26.4 In case of any defect/defective workmanship observed at any stage by the purchaser's inspecting officer; the same shall be pointed out to the firm in writing for taking remedial measures. Further processing should only be done after clearance from the Inspecting officer/purchaser.
- 26.5 All tests and inspections shall be carried out at the place of manufacture unless otherwise specifically agreed upon by the manufacturer and purchaser at the time of purchase. The manufacturer shall offer the inspector representing the purchaser all reasonable facilities, without charges, to satisfy him that the material is being supplied in accordance with this specification. This will include stage inspection during manufacturing stages as well as active part inspection during acceptance tests.
- 26.6 The manufacturer shall provide all services to establish and maintain quality of workmanship in his work and that of his sub-contractors to ensure the mechanical/electrical performance of components, compliance with drawings, identification and acceptability of all materials, parts and equipment as per latest quality standards of ISO 9000.
- 26.7 Along with the bid the manufacturer shall prepare Quality Assurance Plan (QAP) identifying the various stages of manufacture, quality checks performed at each stage and the customer hold points. The documents shall also furnish details of method of checking, inspection and acceptance standards/value and get the approval of purchaser or his representative before proceeding with manufacturing. However, purchaser or his representatives shall have the right to review the inspection reports, quality checks and results of manufacturer's in-house inspection department which are not customer hold points and the manufacturer shall comply with the remarks made by purchaser or his representative on such reviews.

with regard to further testing, rectification or rejection etc. Manufacturers should submit the list of equipment for testing along with latest calibration certificates to the purchaser.

- 26.8 Purchaser shall have every right to appoint a third party inspection to carry out the inspection process. The purchaser has the right to have the test carried out at his own cost by an independent agency wherever there is a dispute regarding the quality of supply. Purchaser has right to test 1% of the supply selected either from the stores or field to check the quality of the product. In case of any deviation purchaser has every right to reject the entire lot or penalise the manufacturer, which may lead to blacklisting among other things.

**27 QUALITY ASSURANCE PLAN:**

- 27.1 The bidders shall invariably furnish following information along with his bid, failing which his bid shall be liable for rejection. Information shall be separately given for individual type of material offered.
- 27.2 Statement giving list of important raw materials, names of sub-suppliers for the raw materials, list of standards according to which the raw materials are tested, list of tests normally carried out on raw materials in presence of bidder's representative and copies of test certificates.
- 27.3 Information and copies of test certificates as above in respect of bought out accessories.
- 27.4 List of manufacturing facilities available.
- 27.5 Level of automation achieved and list of areas where manual processing exists.
- 27.6 List of areas in manufacturing process, where stage inspections are normally carried out for quality control and details of such tests and inspections.
- 27.7 List of testing equipment available with the bidder for final testing of equipment along with valid calibration reports shall be furnished with the bid. Manufacturers shall possess 0.1 accuracy class instruments for measurement of losses.
- 27.8 Quality assurance plan with hold points for purchaser's inspection.
- 27.9 The successful bidder shall within 30 days of placement of order, submit following information to the purchaser.
- 27.9.1 List of raw materials as well as bought out accessories and the names of sub-suppliers selected from those furnished along with offer.
- 27.9.2 Type test certificates of the raw materials and bought out accessories.
- 27.10 The successful bidder shall submit the routine test certificates of bought out accessories and central excise passes for raw material at the time of routine testing.
- 27.11 ISI marking on the transformer is mandatory. As per Quality Control Order for Electrical Transformers- 2015, issued by Dept. of Heavy Industries, the Standard / ISI marking on Distribution Transformers is mandatory and the product should be manufactured in compliance with IS 1180 Part-1:(2014).

**28 DOCUMENTATION:**

- 28.1 Completely dimensioned drawings indicating general arrangement and details of fittings, clearances and winding details shall accompany the tender.
- 28.2 Drawings of internal constructional details and fixing details of coils should also be indicated. Tank dimensions, position of fittings, clearances between leads within the transformer, core grade of laminations, distance of core centers, area of conductor bare and within insulation. No. of coils, No. of turns per coil material

lofbushingmetalpartsetc.,shallalsobefurnishedwithtender.

**29 PACKINGandFORWARDING:**

- 29.1 Thepackingshall bedoneas per themanufacturer’sstandardpractice. However,heshouldensurethepackingissuchthat,thematerialshouldnotgetdamagedduringtransit by rail/road.
- 29.2 The markingoneachpackageshall beas pertherelevantIS.

**30 GUARANTEE:**

- 31.1 The manufacturers of the transformer shall provide a guarantee of 60 months from the date of receipt of transformer at the stores of the Utility. In case the transformer fails within the guarantee period, the supplier will depute his representative within 15 days from date of intimation by utility for joint inspection. In case, the failure is due to the reasons attributed to supplier, the transformer will be replaced/repared by the supplier within 2 months from date of joint inspection.
- 31.2 Theoutageperiodi.e.periodfromthedateoffailuretillunitisrepaired/replacedshallnotbecounted forarrivingat theguarantee period.
- 31.3 Intheeventof thesupplier’sinability to adhere to theaforesaidprovisions,suitable penalactionwill betakenagainststhesupplier,which mayinteralia includeblacklistingofthefirmfor futurebusinesswiththepurchaserfor a certainperiod.

**Methodologyforcomputingtotalowningcost  
Annex-I**

<b>TOC=IC+(A×Wi) +(B×Wc) ; Losses in KW</b>			
Where,			
TOC	=	TotalOwningCost	
IC	=	Initialcost including taxes of transformer as quoted by the manufacturer	
Afactor	=	Cost of no load lossesinRs/KW	(A = 288239)
Bfactor	=	Cost of load lossesin Rs/KW	(B = 93678)
Wi	=	Noloadlosses quoted by themanufacturerin KW	



Wc	=	Load losses quoted by the manufacturer in KW
----	---	--

Note:

No (+)ve tolerance shall be allowed at any point of time on the quoted losses after the award. In case, the losses during type testing ,routine testing etc. are found above the quoted losses, the award shall stand cancelled. In such a case, the CPG money shall also be forfeited.

**Annexure-Paint**

	Surface Preparation	primer coat	intermediate under coat	finish coat	total DFT	Colour shade
Main tank, pipes, conservator tank, etc. (External surfaces)	Blast cleaning Sa2½	Epoxy base Zinc primer 30-40 micron	Epoxy base Zinc primer 30-40 micron	Aliphatic Polyurethane (PU Paint) (min 50 micron	Min 110 micron	541 shade of IS:5

Main tank, pipes (above 80 NB), conservator tank, etc (Internal surfaces)	Blast cleaning Sa2½	Hot oil resistant, non-corrosive varnish or paint	--	--	Min 30 micron	Glossy white for paint
Radiator (External surfaces)	Chemical / blast cleaning (Sa2½)	Epoxy base zinc primer 30-40 micron	Epoxy base Zinc primer Min 30-40 micron	Aliphatic Polyurethane (PU Paint) (min)50 micron	Min 110 micron	541 shade of IS:5
Radiator and pipes up to 80 NB (Internal surfaces)	Chemical cleaning if required	Hot oil proof low viscosity varnish or hot oil resistant non corrosive paint	--	--	--	Glossy white for paint

**Painting-Transformer Main tank, pipes, Conservator Tank, Radiator etc.-**

**Schedule IA**

**GUARANTEED TECHNICAL PARTICULARS FOR COMPLETELY SELF PROTECTED DISTRIBUTION TRANSFORMERS**

**Sl.No.Description    6.3kVA    10 kVA 16kVA 25kVA**

1. Name of the manufacturer and place of manufacture
2. Continuous maximum rating as per this specification.
3. Normal ratio of transformer

4. Method of connection HV/LV
5. Maximum current density in Windings :
  1. HV (A/sqmm)
  2. LV (A/sqmm)
6. Maximum hotspot temperature<sup>0</sup>C. (Ambient air temperature on which above is based)<sup>0</sup>C.
7. Maximum temperature:<sup>0</sup>C
  - (a) Maximum observable oil temperature (ambient air temperature on which above is based)
  - (b) Maximum winding temperature at ambient temperature of
8. No-load losses at rated voltage (watt)
9. Full load losses at 75<sup>0</sup>C (watt)
10. Total losses at 100% load (watt)
11. Total losses at 50% load (watt)
12. Efficiency at normal voltage :
  - (i) Unity Power Factor
    - (a) At 50% load
    - (b) At 75% load
    - (c) At full load
  - (ii) 0.8 Power Factor
    - (a) At 50% load
    - (b) At 75% load
    - (c) At full load
13. Regulation as percentage of normal voltage:
  - (a) At unity power factor
  - (b) At 0.8 power factor lagging
14. Percentage impedance voltage at normal ratio between HV and LV windings
15. Type of transformers, CRGO/ amorphous type
16. Type of insulation used in
  - HV Winding
  - LV Windings
17. Type of insulation used in
  - Core bolts
  - Core bolt washers
  - End plates
  - Core lamination
18. Impulse withstand test voltage level (kV)
  - HV Windings
  - LV Windings
19. Characteristics of transformer oil
20. Total content of oil in litres

- 21. Whether transformer will be transported without?
- 22. Type of transformer tank
- 23. Approximate overall dimensions

- a) Height                      mm
- b) Length                     mm
- c) Width                      mm

Tank dimensions

- a) Diameter                  mm
- b) Height                     mm

- 24. Mass of insulated conductor
  - HV  
(minimum) kg
  - LV  
(minimum) kg
- 25. Mass of core (minimum) kg (CRGO or amorphous metal)
- 26. Mass of complete transformer arranged for transport (kg)

**ADDITIONAL DETAILS**

Schedule IB

Sl.No.	Description	
1.	Core grade	
2.	Core dimensions	mm
3.	Gross core area	cm <sup>2</sup>
4.	Net Core area	cm <sup>2</sup>
5.	Flux density	Tesla
6.	Mass of Core	kg
7.	Loss per kg of core at the specified flux density	watt
8.	Core window height	mm
9.	Center to center distance of the core	mm
10.	No. of LV Turns	

11.	No. of HVturns	
12.	Size ofLV Conductorbare/ covered(dia)	mm
13.	Size of HV conductorbare/covered(dia)	mm
14.	No.ofparallels	
15.	CurrentdensityofLVwinding	A/sq mm
16.	CurrentdensityofHVwinding	A/sq mm
17.	Massof the LV winding forTransformer	kg
18.	Massofthe HVwinding forTransformer	kg
19.	No.ofofLVCoils/phase	
20.	No. of HVcoils.phase	
21.	Height ofLVWindings	mm
22.	Height ofHVwinding	mm
23.	ID/ODofLVwindingHV	mm
24.	ID/ODofLVwinding	mm
25.	Sizeofthe ductinLVwinding	mm
26.	Sizeofthe ductinHVwinding	mm
27.	Sizeofthe ductbetween HV andLV	mm
28.	HV windingto LVclearance	mm
29.	HV windingto tank clearance	mm
30.	Calculatedimpedance	%
31.	HVto earthcreepagedistance	mm
32.	LV to earthcreepagedistance	mm

**ScheduleII**

**SOURCEOFMATERIALS/PLACESOFMANUFACTURE, TESTINGAND**

**INSPECTION**

Sl.No.	Item	Sourceof Material	PlaceofManu facture	Placeoftesti ngandinspe ction
1.	Laminations			
2.	Aluminium/Copper			
3.	Insulated windingwires			

4.	Oil			
5.	Pressboards			
6.	Kraftpaper			
7.	MSplates/Angles/Channels			
8.	Gaskets			
9.	Bushing HV/LV			
10.	Paints			

**Annexure - A**

**Check-list for Inspection of Prime quality CRGO for Transformers**

During inspection of PRIME CRGO, the following points needs to be checked by the Transformer manufacturer. Utility's inspector shall verify all these points during inspection:-

ii) **In case PRIME CRGO cutting is at works of Transformer Manufacturer:**

Review of documents:

Purchase Order (unpriced) to PRIME CRGO supplier/Authorised Agency  
 Manufacturer's test certificate

Invoice of the Supplier

Packing List

Bill of Lading  
 Bill of Entry Certificate by Customs Deptt.  
 Reconciliation Statement as per format below  
 Certificate of Origin  
 BIS Certification

**Format for Reconciliation/Traceability records**

Packing List No./date /Quantity of PRIME CRGO received

Name of Manufacturer

Manufacturer test certificate No./date

Serial No.	Details of Package/Job	Drawing reference	Quantity Involved	Commulative Quantity Consumed	Balance Stock

(iii) .1 Inspection of PRIME CRGO Coils:

PRIME CRGO-Manufacturer’s Identification Slip on PRIME CRGO Coils

**Visual Inspection of PRIME CRGO Coils offered as per packing list ( for verification of coil details as per Test certificate & healthiness of packaging).**

**Unique numbering inside of each sample of PRIME CRGO coil and verification of records to be maintained in the register for consumption of CRGO coil.**

**ISI logo sticker on packed mother coil and ISI logo in Material TC.**

2.2. During inspection of PRIME CRGO, surveillance testing of sample shall be carried out for Stacking Factor, Permeability, Specific watt loss at 1.5 Tesla and/or 1.7 Tesla depending on the grade of PRIME CRGO and aging test etc. applicable as per relevant IS/ IEC standard, Tech. Spec., MQP and Transformer manufacturer plant standard.

**Inspection Clearance Report would be issued after this inspection**

3 Inspection of PRIME CRGO laminations: Transformer manufacturer will maintain records for traceability of laminations to prime CRGO coils and burr/bow on laminations shall be measured. Utility can review these records on surveillance basis.

4. Inspection at the time of core building:

Visual Inspection of PRIME CRGO laminations. In case of suspected mix-up/ rusting/decoloration, samples may be taken for testing on surveillance basis for tests mentioned in A.2.2 above.

Above tests shall be witnessed by Utility. In case testing facilities are not available at Manufacturer’s work, the sample(s) sealed by Utility to be sent to approved labs for testing.

**Inspection Clearance Report would be issued after this inspection**

**(ii) In case PRIME CRGO cutting is at Sub-vendor of Transformer Manufacturer:**

Review of documents:

Purchase Order (unpriced) to PRIME CRGO supplier/ Authorised Agency

- Purchase Order (unpriced) to Core Cutter
- Manufacturer test certificate
- Invoice of the Supplier
- Packing List
- Bill of Lading
- Bill of Entry Certificate by Customs Deptt.
- Reconciliation Statement as per format below
- Certificate of origin
- BIS Certification

**Format for Traceability records as below:-**

Packing List No./date /Quantity of PRIME CRGO received

Serial No.	Name of consumer	Details of Package/Job	Drawing reference	Quantity Involved	Commulative Quantity Consumed	Balance Stock	Dispatch

(iv) .1 Inspection of PRIME CRGO Coils:

PRIME CRGO-Manufacturer’s Identification Slip on PRIME CRGO Coils

**Visual Inspection of PRIME CRGO Coils offered as per packing list ( for verification of coil details as per Test certificate & healthiness of packaging).**

**Unique numbering inside of each sample of PRIME CRGO coil and verification of records to be maintained in the register for consumption of CRGO coil.**

**ISI logo sticker on packed mother coil and ISI logo in Material TC.**

- 2.2. During inspection of PRIME CRGO, surveillance testing of sample shall be carried out for Stacking Factor, Permeability, Specific watt loss at 1.5 Tesla and/or 1.7 Tesla, thickness depending on the grade of PRIME CRGO and aging test etc. applicable as per relevant IS/ IEC standard, Tech. Spec., MQP and Transformer manufacturer plant standard.

**Inspection Clearance Report would be issued after this inspection**

3 Inspection of PRIME CRGO laminations:

Transformer manufacturer representative will inspect laminations and issue their internal Inspection Clearance Report. Inspection will comprise of review of traceability to prime CRGO coils, visual Inspection of PRIME CRGO laminations and record of burr/bow. After clearance given by transformer manufacturer, Utility will issue an Inspection Clearance Report after record review. If so desired by Utility, their representative may also join transformer manufacturer representative during this inspection.

**Inspection Clearance Report would be issued after this inspection**

vii) Inspection at the time of core building:

Visual Inspection of PRIME CRGO laminations. In case of suspected mix-up/rusting/decoloration, samples may be taken for testing on surveillance basis for tests mentioned in B.2.2.

**Inspection Clearance Report would be issued after this inspection**



**NOTE :-**

a) Transformer Manufacturer to ensure that PRIME CRGO is procured from POWERGRID approved vendors and CRGO manufacturer should have valid BIS Certificate for respective offered Grade.

14.2 Transformer Manufacturer should also involve themselves for ensuring the quality of CRGO laminations at their Core Cutter's works. They should visit the works of their Core cutter and carry out necessary checks.

**b) General**

If a surveillance sample is drawn and sent to TPL (if testing facility not available with the manufacturer), the Transformer manufacturer can continue manufacturing at their own risk and cost pending TPL test report on PRIME CRGO sample drawn. Decision for acceptance of PRIME CRGO shall be based upon report of the sample drawn.

**These checks shall be read in-conjunction with approved Quality Plan, specification as a whole and conditions of contract.**

**Sampling Plan (PRIME CRGO)**

33 / 11 kV	-1 <sup>st</sup> transformer and subsequently at random 10% of Transformers (min. 1) offered for inspection.
DTs and other ratings	-1 <sup>st</sup> transformer and subsequently at random 2% of Transformers (min. 1) offered for inspection.

**NOTE:-** One sample for each lot of CRGO shall be drawn on surveillance basis.

CRGO has to be procured only from POWERGRID approved vendors. List of such vendors is available at the following website. Since the list is dynamic in nature, the site may be checked from time to time to see the list of approved vendors.

<http://apps.powergridindia.com/ims/ComponentList/Power-former%20upto%20420%20kV-CM%20List.pdf>

**3-Phase Distribution Transformers 11 or 33 kV/433-250V (Outdoor Type)**

**1. SCOPE:**

- i) This specification covers design, engineering, manufacture, assembly, stage testing, inspection and testing before supply and delivery at site of oil immersed, naturally cooled 3-phase 11kV/433-250V and 33kV/433-250 V distribution transformers for outdoor use.
- ii) The equipments shall conform in all respects to high standards of engineering, design and workmanship and shall be capable of performing in continuous commercial operation, in a manner acceptable to the purchaser, who will interpret the meanings of drawings and specification and shall have the power to reject any work or material which, in his judgment is not in accordance therewith. The offered equipments shall be complete with all components necessary for their effective and trouble free operation. Such components shall be deemed to be within the scope of bidder's supply irrespective of whether these are specifically brought out in this specification and / or the commercial order or not.
- iii) The transformer and accessories shall be designed to facilitate operation, inspection, maintenance and repairs. The design shall incorporate every precaution and provision for the safety of equipments as well as staff engaged in operation and maintenance of equipment.

- iv) All outdoor apparatus, including bushing insulators with their mountings, shall be designed so as to avoid any accumulation of water.

**2 STANDARD RATINGS:**

The standard ratings shall be 16, 25, 63, 100, 160, 200, 250, 315, 400, 500, 630, 1000, 1250, 1600, 2000 and 2500 kVA for 11 kV distribution transformers and 100, 160, 200, 315, 400, 500, 630, 1000, 1250, 1600, 2000, 2500 kVA for 33 kV distribution transformers.

**3 STANDARDS:**

- 3.1 The major materials used in the transformers shall conform in all respects to the relevant/specified Indian Standards and international Standards with latest amendments thereof as on bid opening date, unless otherwise specified herein. Some of the applicable Indian Standards are listed as hereunder:

3.2

Indian Standard	Title	International Standard
IS-2026	Specification for Power Transformers	IEC76
IS1180 (Part-I): 2014	Outdoor Type Oil Immersed Distribution Transformers upto and including 2500 kVA, 33 kV - Specification	
IS12444	Specification for Copper wire rod	ASTMB-49
IS-335	Specification for Transformer/Mineral Oil	IEC Pub296
IS-5	Specification for colors for ready mixed paints	
IS-104	Ready mixed paint, brushing zinc chromate, priming	
IS-2099	Specification for high voltage porcelain bushing	
IS-649	Testing for steel sheets and strips and magnetic circuits	
IS-3024	Cold rolled grain oriented electrical sheets and strips	
IS -4257	Dimensions for clamping arrangements for bushings	
IS -7421	Specification for Low Voltage bushings	
IS -3347	Specification for Outdoor Bushings	DIN42531 to 33
IS -5484	Specification for Al Wire rods	ASTMB- 233
IS -9335	Specification for Insulating Kraft Paper	IEC554
IS -1576	Specification for Insulating Press Board	IEC641
IS -6600	Guide for loading of oil Immersed Transformers	IEC76

IS -2362	Determination of water content in oil for porcelain bushing of transformer	
IS -6162	Paper covered Aluminium conductor	
IS -6160	Rectangular Electrical conductor for electrical machines	
IS -5561	Electrical power connector	
IS -6103	Testing of specific resistance of electrical insulating liquids	
IS -6262	Method of test for power factor and dielectric constant of electrical insulating liquids	
IS -6792	Determination of electrical strength of insulating oil	
IS -10028	Installation and maintenance of transformers.	

**4 SERVICE CONDITIONS:**

- 4.1 The Distribution Transformer to be supplied against this Specifications shall be suitable for satisfactory continuous operation under the following climatic conditions as per IS2026 (Part-I).

- i) Location : At various locations in the country

- ii) Maximum ambient air temperature (<sup>0</sup>C) : 50
- iii) Minimum ambient air temperature (<sup>0</sup>C) : -5
- iv) Maximum averagedaily ambient air temperature (<sup>0</sup>C): 40
- v) Maximum yearly weighted average ambient temperature (<sup>0</sup>C) : 32
- vi) Maximum altitude above Altitude of 5000 meters mean sea level (meters) :  
for HP, J&K, Uttarakhand, Sikkim , Assam, Meghalaya, Manipur, Nagaland, Tripura, Arunachal Pradesh and Mizoram

Note:

1. The climatic conditions specified above are indicative and can be changed by the user as per requirements.
2. The equipments shall generally be for use in moderately hot and humid tropical climate, conducive to rust and fungus growth unless otherwise specified.

**5 PRINCIPAL PARAMETERS:**

5.1 The transformers shall be suitable for outdoor installation with three phase, 50Hz, 11kV or 33kV system in which the neutral is effectively earthed and they should be suitable for service with fluctuations in supply voltage up to plus 12.5% to minus 12.5%.

(i) The transformers shall conform to the following specific parameters:

Sl.No.	Item	11kV Distribution Transformers	33kV Distribution Transformers
1	System voltage (Max.)	12 kV	36 kV
2	Rated Voltage (HV)	11 kV	33 kV
3	Rated Voltage (LV)	433 -250V*	433 -250V*
4	Frequency	50 Hz +/-5%*	50 Hz +/-5%
5	No. of Phases	Three	Three
6	Connection HV	Delta	Delta
7	Connection LV	Star (Neutral brought out)	Star (Neutral brought out)
8	Vector group	Dyn-11	Dyn-11
9	Type of cooling	ONAN	ONAN

Audible sound levels (decibels) at rated voltage and frequency for liquid immersed distribution transformers shall be as below (NEMA Standards):

kVA rating	Audible sound levels (decibels)
0-50	48
51-100	51
101-300	55
301-500	56
750	57
1000	58
1500	60
2000	61
2500	62

**TECHNICAL REQUIREMENTS:**

**6.1.1 CORE MATERIAL**

6.1.2.1 The core shall be stack/wound type of high grade Cold Rolled Grain Oriented or Amorphous Core annealed steel lamination having low loss and good grain properties, coated with hot oil proof insulation, bolted together and to the frames firmly to prevent vibration or noise. The core shall be stress relieved by annealing under inert atmosphere if required. The completed design of core must ensure permanency of the core loss with continuous working of the transformers. The value of the maximum flux density allowed in the design and grade of lamination used shall be clearly stated in the offer.

6.1.2.2 The bidders should offer the core for inspection and approval by the purchaser during manufacturing stage. CRGO steel for core shall be purchased only from the approved vendors, list of which is available at <http://apps.powergridindia.com/ims/ComponentList/Power-former%20upto%20420%20kV-CM%20List.pdf>

6.1.2.3 The transformer core shall be suitable for overfluxing (due to combined effect of voltage and frequency) upto 12.5% without injurious heating at full load conditions and shall not get saturated. The bidders shall furnish necessary design data in support of this situation.

6.1.2.4 No-load current upto 200 kVA shall not exceed 3% of full load current and will be measured by energising the transformer at rated voltage and frequency. Increase of 12.5% of rated voltage shall not increase the no-load current by 6% of full load current.

or

No-load current above 200 kVA and upto 2500 kVA shall not exceed 2% of full load current and will be measured by energising the transformer at rated voltage and frequency. Increase of 12.5% of rated voltage shall not increase the no-load current by 5% of full load current.

6.1.2.5 Please refer to "**Check-list for Inspection of Prime quality CRGO for Transformers**" attached at Annexure-A. It is mandatory to follow the procedure given in this Annexure.

**7 WINDINGS:**

**(i) Material:**

- 7.1.1 HV and LV windings shall be wound from Super Enamel covered / Double Paper covered Aluminum / Electrolytic Copper conductor.
- 7.1.2 LV windings shall be such that neutral formation will be at top.
- 7.1.3 The winding construction of single HV coil wound over LV coil is preferable.
- 7.1.4 Inter layer insulation shall be Nomex/Epoxy dotted Kraft Paper.
- 7.1.5 Proper bonding of interlayer insulation with the conductor shall be ensured. Test for bonding strength shall be conducted.
- 7.1.6 Dimensions of winding coils are very critical. Dimensional tolerances for winding coils shall be within limits as specified in Guaranteed Technical Particulars (GTP Schedule I).
- 7.1.7 The core/coil assembly shall be securely held in position to avoid any movement under short circuit conditions.
- 7.1.8 Joints in the windings shall be avoided. However, if jointing is necessary the joints shall be properly brazed and the resistance of the joints shall be less than that of parent conductor. In case of foil windings, welding of leads to foil can be done within the winding.

**8 TAPPING RANGES AND METHODS:**

- 8.1.1 No tapping shall be provided for distribution transformers up to 100 kVA rating.
- 8.1.2 The tapping shall be as per provisions of IS: 1180 Part-I (2014).
- 8.1.3 Tap changing shall be carried out by means of an externally operated self-position switch and when the transformer is in de-energised condition. Switch position No. 1 shall correspond to the maximum plus tapping. Each tap change shall result in variation of 2.5% in voltage. Arrangement for padlocking shall be provided. Suitable aluminum anodized plates shall be fixed for tap changing switch to know the position number of tap.

**9 OIL:**

- 9.1 The insulating oil shall comply with the requirements of IS 335. Use of recycled oil is not acceptable. The specific resistance of the oil shall be as per IS 335.
- 9.2 Oil shall be filtered and tested for breakdown voltage (BDV) and moisture content before filling.
- 9.3 The oil shall be filled under vacuum.
- 9.4 The design and all materials and processes used in the manufacture of the transformer, shall be such as to reduce to a minimum the risk of the development of acidity in the oil.

**10 INSULATION LEVELS:**

Sl. No.	Voltage (kV)	Impulse Voltage (kV Peak)	Power Frequency Voltage (kV)
1	0.433	-	3
2	11	75	28
3	33	170	70

**11 LOSSES:**

11.1 The transformer of HV voltage upto 11kV, the total losses (no-load + load losses at 75<sup>0</sup>C) at 50% of rated load and total losses at 100% of rated load shall not exceed the maximum total loss values given in Table-3 upto 200kVA & Table-6 for ratings above 200kVA of IS 1180 (Part-1):2014.

11.2 The maximum allowable losses at rated voltage and rated frequency permitted at 75<sup>0</sup>C for 11/0.433kV transformers can be chosen by the utility as per **Table-3 upto 200kVA and Table-6 for ratings above 200kVA as per Energy Efficiency Level-2 specified in IS 1180 (Part-1):2014** for all kVA ratings of distribution transformers.

11.3 The above losses are maximum allowable and there would not be any positive tolerance. Bids with higher losses than the above specified values would be treated as non-responsive. However, the manufacturer can offer losses less than above stated values. The utility can evaluate offers with losses lower than the maximum allowable losses on total owning cost basis in accordance with methodology given in Annex-I.

**12 TOLERANCES:**

12.1 No positive tolerance shall be allowed on the maximum losses displayed on the label for both 50% and 100% loading values.

**13 PERCENTAGE IMPEDANCE:**

The percentage impedance of transformers at 75<sup>0</sup>C for different ratings upto 200kVA shall be as per Table 3 and for ratings beyond 200 kVA shall be as per Table 6 of IS 1180 (Part-1):2014.

**14 Temperature rise:** The temperature rise over ambient shall not exceed the limits given below:

14.1 The permissible temperature rise shall be as per IS: 1180 (Part-I):2014.

14.2 The transformers shall be capable of giving continuous rated output without exceeding the specified temperature rise. Bidders shall submit the calculations sheet in this regard.

**15 PENALTY FOR NON PERFORMANCE:**

15.1 During testing at supplier's works if it is found that the actual measured losses are more than the values quoted by the bidder, the purchaser shall reject the transformer and he shall also have the right to reject the complete lot.

15.2 Purchaser shall reject the entire lot during the test at supplier's works, if the temperature rise exceeds the specified values.

15.3 Purchaser shall reject any transformer during the test at supplier's works, if the impedance values differ from the guaranteed values including tolerance.

**16 INSULATION MATERIAL:**

16.1 Electrical grade insulation epoxy dotted Kraft Paper/Nomex and pressboard of standard make or any other superior material subject to approval of the purchaser shall be used.

16.2 All spacers, axial wedges/runners used in windings shall be made of pre-compressed Pressboard-solid, conforming to type B3.1 of IEC 641-3-2. In case of cross-over coil winding of HV all spacers shall be properly sheared and dovetail punched to ensure proper locking. All axial wedges/runners shall be properly milled to dovetail shapes so that they pass through the designed spacers freely. Insulation shearing, cutting, milling and punching operations shall be carried out in such a way, that there should not be any burr and dimensional variations.

**17.1 TANK:**

- Transformer tank construction shall conform in all respect to clause 15 of IS1180(Part-1):2014.
- The internal clearance of tank shall be such, that it shall facilitate easy lifting of core with coils from the tank without dismantling LV bushings.
- All joints of tank and fittings shall be oil tight and no bulging should occur during service.
- Inside of tank shall be painted with varnish/hot oil resistant paint.
- The top cover of the tank shall be slightly sloping to drain rain water.
- The tank plate and the lifting lugs shall be of such strength that the complete transformer filled with oil may be lifted by means of lifting shackle/Hook Type.
- Manufacturer should carry out all welding operations as per the relevant ASME standards and submit a copy of the welding procedure and welder performance qualification certificate to the customer.

**i) PLAIN TANK:**

- 17.2.1 The transformer tank shall be of robust construction rectangular/octagonal/round/elliptical in shape and shall be built up of electrically tested welded mild steel plates of thickness of 3.15mm for the bottom and top and not less than 2.5mm for the sides for distribution transformers up to and including 25kVA, 5.0mm and 3.15mm respectively for transformers of more than 25kVA and up to and including 100 kVA and 6mm and 4 mm respectively above 100kVA. Tolerances as per IS1852 shall be applicable.
- 17.2.2 In case of rectangular tanks above 100kVA the corners shall be fully welded at the corners from inside and outside of the tank to withstand a pressure of 0.8kg/cm<sup>2</sup> for 30 minutes. In case of transformers of 100kVA and below, there shall be no joints at corners and there shall not be more than 2 joints in total.
- 17.2.3 Under operating conditions the pressure generated inside the tank should not exceed 0.4 kg/sq. cm positive or negative. There must be sufficient space from the core to the top cover to take care of oil expansion. The space above oil level in the tank shall be filled with dry air or nitrogen conforming to commercial grade of IS 1747 for DT up to 63 KVA. For DT of 63 KVA and above rating, conservator shall be provided.

- (i) The tank shall be reinforced by welded flats on all the outside walls on the edge of the tank.
- (ii) Permanent deflection: The permanent deflection, when the tank without oil is subjected to a vacuum of 52.5mm of mercury for rectangular tank and 760mm of mercury for round tank, shall not be more than the values as given below:

(All figures are in mm)

<b>Horizontal length of flat plate</b>	<b>Permanent deflection</b>
Upto and including 750	5.0
751 to 1250	6.5
1251 to 1750	8.0
1751 to 2000	9.0

17.2.4 The tank shall further be capable of withstanding a pressure of 0.8 kg/sq.cm and a vacuum of 0.7 kg/sq.cm (g) without any deformation.

17.2.5 The radiators can be tube type or fin type or pressed steel type to achieve the desired cooling to limit the specified temperature rise.

**17.3 CORRUGATED TANK:**

17.3.1 The bidder may offer corrugated tanks for transformers of all ratings.

17.3.2 The transformer tank shall be of robust construction corrugated in shape and shall be built up of tested sheets.

17.3.3 Corrugation panel shall be used for cooling. The transformers shall be capable of giving continuous rated output without exceeding the specified temperature rise. Bidders shall submit the calculations sheet in this regard.

17.3.4 Tanks with corrugation shall be tested for leakage test at a pressure of 0.25 kg/sq.cm measured at the top of the tank.

17.3.5 The transformers with corrugation should be provided with a pallet for transportation, the dimensions of which should be more than the length and width of the transformer tank with corrugations.

**18 CONSERVATOR:**

(i) Transformers of rating 63 kVA and above with plain tank construction, the provision of conservator is mandatory. For corrugated tank and sealed type transformers with or without inert gas cushion, conservator is not required.

(ii) When a conservator is provided, oil gauge and the plain or dehydrating breathing devices shall be fitted to the conservator which shall also be provided with a drain plug and a filling hole [32 mm (1 ¼")] normal size thread with cover. In addition, the cover of the main tank shall be provided with an air release plug.

(iii) The dehydrating agents shall be silica gel. The moisture absorption shall be indicated by a change in the color of the silica gel crystals which should be easily visible from a distance. Volume of breathers shall be suitable for 500 g of silica gel conforming to IS 3401 for transformers up to 200 kVA and 1 kg for transformers above 200 kVA.

(iv) The capacity of a conservator tank shall be designed keeping in view the total quantity of oil and its contraction and expansion due to temperature variations. The total volume of conservator shall be such as to contain 10% quantity of the oil. Normally 3% quantity of the oil shall be contained in the conservator.

(v) The cover of main tank shall be provided with an air release plug to enable air trapped within to be released, unless the conservator is so located as to eliminate the possibility of air being trapped within the main tank.

(vi) The inside diameter of the pipe connecting the conservator to the main tank should be within 20 to 50 mm and it should be projected into the conservator so that it ends approximately 20 mm above the bottom of the conservator so as to create a sump for collection of impurities. The minimum oil level (corresponding to 5<sup>0</sup>C) should be above the sump level.

**19 SURFACE PREPARATION AND PAINTING:**



**(i) GENERAL**

19.1.1 All paints, when applied in a normal full coat, shall be free from runs, sags, wrinkles, patchiness, brush marks or other defects.

19.1.2 All primers shall be well marked into the surface, particularly in areas where repainting is evident and the first priming coat shall be applied as soon as possible after cleaning. The paint shall be applied by airless spray according to manufacturer's recommendations. However, wherever airless spray is not possible, conventional spray be used with prior approval of purchaser.

**19.2 CLEANING AND SURFACE PREPARATION:**

a) After all machining, forming and welding has been completed, all steel work surfaces shall be thoroughly cleaned of rust, scale, welding slag or spatter and other contamination prior to any painting.

b) Steel surfaces shall be prepared by shot blast cleaning (IS 9954) to grade Sq. 2.5 of ISO 8501-1 or chemical cleaning including phosphating of the appropriate quality (IS 3618).

c) Chipping, scraping and steel wire brushing using manual or power driven tools cannot remove firmly adherent mill-scale. These methods shall only be used where blast cleaning is impractical. Manufacturer to clearly explain such areas in his technical offer.

**19.3 PROTECTIVE COATING:**

19.3.1 As soon as all items have been cleaned and within four hours of the subsequent drying, they shall be given suitable anti-corrosion protection.

**19.4 PAINT MATERIAL:**

i) Following are the types of paint which may be suitably used for the items to be painted at shop and supply of matching paint to site: Heat resistant paint (Hot oil proof) for inside surface

ii) For external surfaces one coat of thermosetting powder paint or one coat of epoxy primer followed by two coats of synthetic enamel/polyurethane base paint. These paints can be either air drying or stoving.

iii) For highly polluted areas, chemical atmosphere or for places very near to the sea coast, paint as above with one coat of high build Micaceous iron oxide (MIO) as an intermediate coat may be used.

**19.5 PAINTING PROCEDURE:**

i) All prepared steel surfaces should be primed before visible rusting occurs or within 4 hours, whichever is sooner. Chemical treated steel surfaces shall be primed as soon as the surface is dry and while the surface is still warm.

ii) Where the quality of film is impaired by excess film thickness (wrinkling, mud cracking or general softness) the suppliers shall remove the unsatisfactory paint coating and apply another coating. As a general rule, dry film thickness should not exceed the specified minimum dry film thickness by more than 25%.

**19.6 DAMAGED PAINTWORK:**

(i) Any damage occurring to any part of a painting scheme shall be made good to the same standard of corrosion protection and appearance as that was originally applied.

(ii) Any damaged paint work shall be made good as follows:

19.6.2.1 The damaged area, together with an area extending 25 mm around its boundary, shall be cleaned down to bare metal.

19.6.2.2 A priming coat shall be immediately applied, followed by a full paint finish equal to that originally applied and extending 50 mm around the perimeter of the original damage.

19.6.2.3 The repainted surfaces shall present a smooth surface. This shall be obtained by carefully chamfering the painted edges before and after priming.

19.6.2.4 The paint shade shall be as per Annexure-Paint which is attached herewith.

**19.7 DRY FILM THICKNESS:**

19.7.1 To the maximum extent practicable the coats shall be applied as a continuous film of uniform thickness and free of pores. Overspray, skips, runs, sags and drips should be avoided. The different coats may or may not be of the same colour.

19.7.2 Each coat of paint shall be allowed to harden before the next is applied as per manufacturer's recommendation.

19.7.3 Particular attention must be paid to full film thickness at the edges.

19.7.4 The requirements for the dry film thickness (DFT) of paint and the material to be used shall be as given below:

Sl. No.	Paint type	Area to be painted	No. of coats	Total dry film thickness (min.) (microns)
1.	Thermosetting powder paint	inside outside	01 01	30 60
2.	<b>Liquid paint</b>			
	a) Epoxy (primer)	outside	01	30
	b) P.U. Paint (Finish coat)	outside	02	25 each
		inside	01	35/10

**19.8 TESTS FOR PAINTED SURFACE:**

19.8.1 The painted surface shall be tested for paint thickness.

19.8.2 The painted surface shall pass the cross hatch adhesion test

and impact test as acceptance tests and Salt spray test and Hardness test as type test as per the relevant ASTM standards.

Note: Suppliers shall guarantee the painting performance requirement for a period of not less than 5 years.

**20 BUSHINGS:**

20.1 The bushings arrangement shall be decided by utility during detailed engineering.

20.2 For 33kV-36kV class bushings shall be used for transformers of ratings 500kVA and above. And for transformers below 500KVA, 33kV class bushings, for 11kV -12 kV class bushings and for 0.433 kV-1 kV class bushings shall be used.

20.3 Bushing can be of porcelain/epoxy material. Polymer insulator or bushings conforming with relevant IEC can also be used.

20.4 Dimension of the bushings of the voltage class shall conform to the Standard specified and dimension of clamping arrangements shall be as per IS 4257

20.5 Minimum external phase to phase and phase to earth clearances of bushing terminal shall be as follows:

Voltage	Clearance	
	Phase to phase	Phase to earth
33 kV	350mm	320mm
11 kV	255mm	140mm
LV	75mm	40mm

For DTs of 200 KVA and above, the clearances of cable box shall be as below:

Voltage	Clearance	
	Phase to phase	Phase to earth
33 kV	350mm	220mm
11 kV	130mm	80mm
LV	25mm	20mm

20.6 Arcing horn shall be provided on HV bushings.

20.7 Brazing of all interconnections, jumpers from winding to bushings shall have cross section larger than the winding conductor. All the Brazes shall be qualified as per ASME, section-IX.

20.8 The bushings shall be of reputed make supplied by those manufacturers who are having manufacturing and testing facilities for insulators.

20.9 The terminal arrangements shall not require separate oil chamber not connected to oil in the main tank.

**21 TERMINAL CONNECTORS:**

21.1 The LV and HV bushing stem shall be provided with suitable terminal connectors as per IS 5082 so as to connect the jumper without disturbing the bushing stem. Connectors shall be with eye bolts so as to receive conductor for HV. Terminal connectors shall be type tested as per IS 5561.

**22 LIGHTNING ARRESTORS:**

22.1 9 kV, 5 kA metal oxide lightning arrestors of reputed make conforming to IS 3070 Part-III, one

number per phase shall be provided.( To be mounted on pole or to be fitted under the HV bushing with GI earth strip 25x4 mm connected to the body of the transformer with necessary clamping arrangement as per requirement of purchaser.) Lightning arrestors with polymer insulators in conformance with relevant IEC can also be used. 1 clamp for LA shall also be provided for each HT bushing. Supply of LA is not included in DT supplier's scope.

**23 CABLEBOXES:**

No cable box shall be provided in transformer below 200 kVA. Above 200kVA, Cable Boxes shall be provided on both HV & LV side.

- 23.1 In case HV/LV terminations are to be made through cables the transformers shall be fitted with suitable cable box on 11kV side to terminate one 11kV/3 core aluminium conductor cable upto 240 sq.mm.(Size as per requirement).

The bidders shall ensure the arrangement of HT Cable box so as to prevent the ingress of moisture into the box due to rain water directly falling on the box. The cable box on HT side shall be of the split type with faces plain and machined and fitted with Neo-k-Tex or similar quality gasket and complete with brass wiping gland to be mounted on separate split type gland plate with nut-bolt arrangement and M S earthing clamp. The bushings of the cable box shall be fitted with nuts and stem to take the cable cores without bending them. The stems shall be of copper with copper nuts. The cross section of the connecting rods shall be stated and shall be adequate for carrying the rated currents. On the HV side the terminal rods shall have a diameter of not less than 12mm. The material of connecting rods shall be copper. HT Cable support clamps should be provided to avoid tension due to cable weight.

- 23.2 The transformers shall be fitted with suitable LV cable box having non-magnetic material gland plate with appropriate sized single compression brass gland on LV side to terminate 1.1kV/single core XLPE armoured cable (Size as per requirement).

**24 TERMINAL MARKINGS:**

High voltage phase windings shall be marked both in the terminal boards inside the tank and on the outside with capital letter 1U, 1V, 1W and low voltage winding for the same phase marked by corresponding small letter 2U, 2V, 2W. The neutral point terminal shall be indicated by the letter 2N. Neutral terminal is to be brought out and connected to local grounding terminal by an earthing strip.

- 26.1 The following standard fittings shall be provided :

- i. Rating and terminal marking plates, non-detachable.
- ii. Earthing terminals with lugs -2 Nos.
- iii. Lifting lugs for main tank and top cover
- iv. Terminal connector on the HV/LV bushings (For bare termination only).
- v. Thermometer pocket with cap -1 No.
- vi. Air release device (for non-sealed transformer)
- vii. HV bushings -3 Nos.
- viii. LV bushings -4 Nos.
- ix. Pulling lugs
- x. Stiffener
- xi. Radiators- No. and length may be mentioned (as per heat dissipation calculations)/corrugations.
- xii. Arcing horns on HT side - 3 No . Only clamps for lightning arrester shall be provided.

- xiii. Prismatic oil level gauge.
- xiv. Drain cum sampling valve.
- xv. One filter valve on upper side of the transformer (For transformers above 200 kVA)
- xvi. Oil filling hole having  $p.1-\frac{1}{4}''$  thread with plug and drain plug on the conservator.
- xvii. Silica gel breather (for non-sealed type transformer)
- xviii. Base channel 75x40mm for up to 100kVA and 100mmx50mm above 100kVA, 460mm long with holes to make them suitable for fixing on a platform or plinth.
- xix. 4 No. rollers for transformers of 200kVA and above.
- xx. Pressure relief device or explosion vent (above 200 kVA)
- xxi. Oil level gauge
  - A. -5 °C and 90°C marking for non-sealed type Transformers
  - B.- 30°C marking for sealed type transformers
- xxii. Nitrogen / air filling device/ pipe with welded cover  
 Capable of reuse (for sealed type transformers)
- xxiii. Inspection hole for transformers above 200 kVA
- xxiii. Pressure gauge for sealed type transformers above 200 kVA.
- xxiv. Buchholz relay for transformers above 1000 KVA.

**27 FASTENERS:**

- 27.1 All bolts, studs, screw threads, pipe threads, bolt heads and nuts shall comply with the appropriate Indian Standards for metric threads, or the technical equivalent.
- 27.2 Bolts or studs shall not be less than 6mm in diameter except when used for small wiring terminals.
- 27.3 All nuts and pins shall be adequately locked.
- 27.4 Wherever possible bolts shall be fitted in such a manner that in the event of failure of locking resulting in the nuts working loose and falling off, the bolt will remain in position.
- 27.5 All bolts/nuts/washers exposed to atmosphere should be as follows.
  - a) Size 12 mm or below – Stainless steel
  - b) Above 12 mm- steel with suitable finish like electro galvanized with passivation or hot dip galvanized.
- 27.6 Each bolt or stud shall project at least one thread but not more than three threads through the nut, except where otherwise approved for terminal board studs or relay systems. If bolts and nuts are replaced so that they are inaccessible by means of ordinary spanners, special spanners shall be provided.
- 27.7 The length of the screwed portion of the bolt shall be such that no screw thread may form part of a shear plane between members.
- 27.8 Taper washers shall be provided where necessary.
- 27.9 Protective washers of suitable material shall be provided front and back of these securing screws.

**28 OVERLOAD CAPACITY:**

28.1 The transformers shall be suitable for loading as per IS 6600.

**29 TESTS:**

29.1 All the equipment offered shall be fully type tested by the bidder or his collaborator as per the relevant standards including the additional type tests. The type test must have been conducted on a transformer of same design **during the last five years** at the time of bidding. The bidder shall furnish four sets of type test reports along with the offer. **In case, the offered transformer is not type tested, the bidder will conduct the type test as per the relevant standards including the additional type tests at his own cost in CPRI/ NABL accredited laboratory in the presence of employers representative(s) without any financial liability to employer in the event of order placed on him.**

29.2 Special tests other than type and routine tests, as agreed between purchaser and bidder shall also be carried out as per the relevant standards.

29.3 The requirements of site tests are also given in this clause.

29.4 The test certificates for all routine and type tests for the transformers and also for the bushings and transformer oil shall be submitted with the bid.

29.5 The procedure for testing shall be in accordance with IS 1180 (Part-1):2014/2026 as the case may be except for temperature rise test.

29.6 Before dispatch each of the completely assembled transformers shall be subjected to the routine tests at the manufacturer's works.

**30 ROUTINE TESTS:**

30.1 Ratio, polarity, phase sequence and vector group.

30.2 No load current and losses at service voltage and normal frequency.

30.3 Load losses at rated current and normal frequency.

30.4 The test certificates for all routine and type tests for the transformers and also for the bushings and transformer oil shall be submitted after the receipt of order.

30.5 Impedance voltage test.

30.6 Resistance of windings at each tap, cold (at or near the test bed temperature).

30.7 Insulation resistance.

30.8 Induced overvoltage withstand test.

30.9 Separate source voltage withstand test.

30.10 Neutral current measurement - The value of zero sequence current in the neutral of the star windings shall not be more than 2% of the full load current.

30.11 Oil samples (one sample per lot) to comply with IS 1866.

30.12 Measurement of no load losses and magnetizing current at rated frequency and 90%, 100% and 110% rated voltage.

30.13 Pressure and vacuum test for checking the deflection on one transformer of each type in every inspection.

**31 TYPETESTSTOBECONDUCTEDONONEUNIT:**

In addition to the tests mentioned in clause 30 and 31 following tests shall be conducted:

- 31.1 Temperature rise test for determining the maximum temperature rise after continuous full load run. The ambient temperature and time of test should be stated in the test certificate.
- 31.2 Impulse voltage test: with chopped wave of IS 2026 part-III. BIL for 11kV shall be 75kV peak.
- 31.3 Short circuit withstand test: Thermal and dynamic ability.
- 31.4 Air Pressure Test: As per IS –1180 (Part-1):2014.
- 31.5 Magnetic Balance Test.
- 31.6 Un-balanced current test: The value of unbalanced current indicated by the ammeters shall not be more than 2% of the full load current.
- 31.7 Noise-level measurement.
- 31.8 Measurement of zero-phase sequence impedance.
- 31.9 Measurement of Harmonic of no-load current.
- 31.10 Transformer tank shall be subjected to specified vacuum. The tank designed for vacuum shall be tested at an internal pressure of 0.35kg per sq cm absolute (250mm of Hg) for one hour. The permanent deflection of flat plates after the vacuum has been released shall not exceed the values specified below:

Horizontal length of flat plate (in mm)	Permanent deflection (in mm)
Upto and including 750	5.0
751 to 1250	6.5
1251 to 1750	8.0
1751 to 2000	9.0

- 31.11 Transformer tank together with its radiator and other fittings shall be subjected to pressure corresponding to twice the normal pressure or 0.35kg/sq. cm whichever is lower, measured at the base of the tank and maintained for an hour. The permanent deflection of the flat plates after the excess pressure has been released, shall not exceed the figures for vacuum test.
- 31.12 Pressure relief device test: The pressure relief devices shall be subject to increasing fluid pressure. It shall operate before reaching the test pressure as specified in the above class. The operating pressure shall be recorded. The device shall seal-off after the excess pressure has been released.
- 31.13 **Short Circuit Test and Impulse Voltage Withstand Tests:** The purchaser intend to procure transformers designed and successfully tested for short circuit and impulse test. In case the transformers proposed for supply against the order are not exactly as per the tested design, the suppliers shall be required to carry out the short circuit test and impulse voltage withstand test at their own cost in the presence of the representative of the purchaser.
- 31.13.1 The supply shall be accepted only after such test is done successfully, as it confirms successful withstand of short circuit and healthiness of the active parts thereafter on un-tanking after a short circuit test.

- 31.13.2 Apart from dynamic ability test, the transformers shall also be required to withstand thermal ability test or thermal withstand ability will have to be established by way of calculations.
- 31.13.3 It may also be noted that the purchaser reserves the right to conduct short circuit test and impulse voltage with stand test in accordance with the IS, afresh on each ordered rating at purchaser cost, even if the transformers of the same rating and similar design are already tested. These tests shall be carried out on a transformer to be selected by the purchaser either at the manufacturer's works when they are offered in a lot for supply or randomly from the supplies already made to purchaser's stores. The findings and conclusions of these tests shall be binding on the supplier.

**32 ACCEPTANCE TESTS:**

- 32.1 **At least 10% transformers of the offered lot (minimum of one)** shall be subjected to the following routine/acceptance test in presence of purchaser's representative at the place of manufacture before dispatch without any extra charges. The testing shall be carried out in accordance with IS:1180 (Part-1):2014 and IS:2026.
- 32.2 Checking of weights, dimensions, fitting and accessories, tank sheet thickness, oil quality, material, finish and workmanship as per GTP and contract drawings on one transformer of each type in every inspection.
- 32.3 Physical verification of core coil assembly and measurement of flux density of one unit of each rating, in every inspection with reference to short circuit test report.
- 32.4 Temperature rise test on one unit of the total ordered quantity.

**33 TESTS AT SITE:**

The purchaser will conduct the following test on receipt of transformers in their store. The utility shall arrange all equipment, tools & tackle and manpower for the testing. The bidder will depute his representative to witness the same. All such test shall be conducted by utility not later than 10 days from receipt of transformers.

- i) Megger Test
- ii) Ratio test

**34 INSPECTION:**

- 34.1 In respect of raw materials such as core stampings, winding conductors, insulating paper and oil, suppliers shall use materials manufactured/supplied by standard manufacturers and furnish the manufacturers' test certificate as well as the proof of purchase from these manufacturers (excise gate pass) for information of the purchaser. The bidder shall furnish following documents along with their offer in respect of the raw materials:

- i. Invoice of supplier.
- ii. Mill's certificate.
- iii. Packing list.
- iv. Bill of lading.
- v. Bill of entry certificate by custom.

Please refer to "**Check-list for Inspection of Prime quality CRGO for Transformers**" attached at Annexure-A. It is mandatory to follow the procedure given in this Annexure.



**35 INSPECTION AND TESTING OF TRANSFORMER OIL:**

- 35.1 To ascertain the quality of the transformer oil, the original manufacturer's tests report should be submitted at the time of inspection. Arrangements should also be made for testing of transformer oil as per IS: 335 , after taking out the sample from the manufactured transformers and tested in the presence of purchaser's representative.
- 35.2 To ensure about the quality of transformers, the inspections shall be carried out by the purchaser's representative at following two stages:-
- 35.2.1 Anytime during receipt of raw material and manufacture/ assembly whenever the purchaser desires.
- 35.2.2 At finished stage i.e. transformers are fully assembled and are ready for dispatch.
- 35.3 The stage inspections shall be carried out in accordance with **Annexure-II**.
- 35.4 After the main raw-material i.e. core and coil material and tanks are arranged and transformers are taken for production on shop floor and a few assemblies have been completed, the firm shall intimate the purchaser in this regard , so that an officer for carrying out such inspection could be deputed, as far as possible within seven days from the date of intimation. During the stage inspection a few assembled cores shall be dismantled to ensure that the laminations used are of good quality. Further, as and when the transformers are ready for despatch, an offer intimating about the readiness of transformers, for final inspection for carrying out tests as per relevant IS shall be sent by the firm along with Routine Test Certificates. The inspections shall normally be arranged by the purchaser at the earliest after receipt of offer for pre-delivery inspection. The proforma for pre-delivery inspection of Distribution transformers is placed at **Annex- III**.
- 35.5 In case of any defect/defective workmanship observed at any stage by the purchaser's Inspecting Officer, the same shall be pointed out to the firm in writing for taking remedial measures. Further process in g should only be done after clearance from the Inspecting Officer/purchaser.
- 35.6 All tests and inspections shall be carried out at the place of manufacture unless otherwise specifically agreed upon by the manufacturer and purchaser at the time of purchase. The manufacturer shall offer the Inspector representing the Purchaser all reasonable facilities, without charges, to satisfy him that the material is being supplied in accordance with this specification. This will include Stage Inspection during manufacturing stage as well as Active Part Inspection during Acceptance Tests.
- 35.7 The manufacturer shall provide all services to establish and maintain quality of workmanship in his works and that of his sub-contractor to ensure the mechanical/electrical performance of components, compliance with drawings, identification and acceptability of all materials, parts and equipments as per latest quality standards of ISO 9000.
- 35.8 Purchaser shall have every right to appoint a third party inspection to carry out the inspection process.
- 35.9 The purchaser has the right to have the test carried out at his own cost by an independent agency where there is a dispute regarding the quality supplied. Purchaser has right to test 1% of the supply selected either from the stores or field to check the quality of the product. In case of any deviation purchaser has every right to reject the entire lot or penalize the manufacturer, which may lead to blacklisting, among other things.

**36 QUALITY ASSURANCE PLAN:**

- 36.1 The bidder shall invariably furnish following information along with his bid, failing which his bid shall be liable for rejection. Information shall be separately given for individual type of equipment offered.

- 36.2 Statement giving list of important raw materials, names of sub-suppliers for the raw materials, list of standards according to which the raw materials are tested, list of tests normally carried out on raw materials in the presence of bidder's representative, copies of test certificates.
- 36.3 Information and copies of test certificates as above in respect of bought out accessories.
- 36.4 List of manufacturing facilities available.
- 36.5 Level of automation achieved and list of areas where manual processing exists.
- 36.6 List of areas in manufacturing process, where stage inspections are normally carried out for quality control and details of such tests and inspection.
- 36.7 List of testing equipment available with the bidder for final testing of equipment along with valid calibration reports. These shall be furnished with the bid. Manufacturers shall possess 0.1 accuracy class instruments for measurement of losses.
- 36.8 Quality Assurance Plan (QAP) with hold points for purchaser's inspection.
- 36.9 The successful bidder shall within 30 days of placement of order, submit following information to the purchaser :
- 36.9.1 List of raw materials as well as bought out accessories and the names of sub-suppliers selected from those furnished along with offer.
- 36.9.2 Type test certificates of the raw materials and bought out accessories.
- 36.9.3 The successful bidder shall submit the routine test certificates of bought out accessories and central excise passes for raw material at the time of routine testing.
- 36.9.4 ISI marking on the transformer is mandatory. As per Quality Control Order for Electrical Transformers- 2015, issued by Department of Heavy Industries, Government of India, the Standard / ISI marking on Distribution Transformers is mandatory and the product should be manufactured in compliance with IS 1180 Part-1: (2014).
- 37 DOCUMENTATION:**
- 37.1 The bidder shall furnish along with the bid the dimensional drawings of the items offered indicating all the fittings.
- 37.2 Dimensional tolerances.
- 37.3 Weight of individual components and total weight.
- 37.4 An outlined drawing front (both primary and secondary sides) and end-elevation and plan of the tank and terminal gear, where in the principal dimensions shall be given.
- 37.5 Typical general arrangement drawings of the windings with the details of the insulation at each point and core construction of transformer.
- 37.6 Typical general arrangement drawings showing both primary and secondary sides and end-elevation and plan of the transformer.
- 38 PACKING AND FORWARDING:**
- 38.1 The packing shall be done as per the manufacturer's standard practice.

However, it should be ensured that the packing is such that, the material would not get damaged during transit by Rail / Road / Sea.

38.2 The marking on each package shall be as per the relevant IS.

**39 GUARANTEE**

41.1 The manufacturers of the transformer shall provide a guarantee of 60 months from the date of receipt of transformer at the stores of the Utility. In case the transformer fails within the guarantee period, the supplier will depute his representative within 15 days from date of intimation by utility for joint inspection. In case, the failure is due to the reasons attributed to supplier, the transformer will be replaced/ repaired by the supplier within 2 months from date of joint inspection.

41.2 The outage period i.e. period from the date of failure till unit is repaired/ replaced shall not be counted for arriving at the guarantee period.

41.3 In the event of the supplier's inability to adhere to the aforesaid provisions, suitable penal action will be taken against the supplier which may inter alia include blacklisting of the firm for future business with the purchaser for a certain period.

**40 SCHEDULES:**

42.1 The bidders shall fill in the following schedule which will be part of the offer. If the schedule are not submitted duly filled in with the offer, the offers shall be liable for rejection.

**Schedule-A : Guaranteed Technical Particulars**

**Schedule-B : Schedule of Deviations**

**41 DEVIATIONS:**

43.1 The bidders are not allowed to deviate from the principal requirements of the Specifications. However, the bidder is required to submit with his bid in the relevant schedule a detailed list of all deviations without any ambiguity. In the absence of a deviation list in the deviations schedule, it is understood that such bid conform to the bid specifications and no post-bid negotiations shall take place in this regard.

43.2 The discrepancies, if any, between the specification and the catalogues and/or literature submitted as part of the offer by the bidders, shall not be considered and representations in this regard shall not be entertained.

43.3 If it is observed that there are deviations in the offering guaranteed technical particulars other than those specified in the deviations schedule then such deviations shall be treated as deviations.

43.4 All the schedules shall be prepared by vendor and are to be enclosed with the bid.

**Annex-I**

**METHODOLOGYFORCOMPUTINGTOTALOWNINGCOST**

<b>TOC=IC+(A×Wi) +(B×Wc) ; Losses in KW</b>		
Where,		
TOC	=	TotalOwningCost
IC	=	Initialcost including taxes of transformer as quoted by the manufacturer
Afactor	=	Cost of no load lossesinRs/KW (A = 288239)
Bfactor	=	Cost of load lossesin Rs/KW (B = 93678)
Wi	=	Noloadlosses quoted by themanufacturerin KW
Wc	=	Load losses quotedby the manufacturer in KW

**Note:** No (+)ve tolerance shall be allowed at any point of time on the quoted losses after the award. In case, the losses during type testing, routine testing etc are found above the quoted losses, the award shall stand cancelled. In such a case, the CPG money shall also be forfeited.

**Annexure-Paint**

**Painting-Transformer Main tank, pipes, Conservator Tank, Radiator etc.-**

	Surface Preparation	primer coat	intermediate under coat	finish coat	total DFT	Colour shade
Main tank, pipes, conservator tank, etc. (External surfaces)	Blast cleaning Sa2½	Epoxy base Zinc primer 30-40 micron	Epoxy base Zinc primer 30-40 micron	Aliphatic Polyurethane (PU Paint) (min 50 micron	Min 110 micron	541 shade of IS:5
Main tank, pipes (above 80 NB), conservator tank, etc (Internal surfaces)	Blast cleaning Sa2½	Hot oil resistant, non-corrosive varnish or paint	--	--	Min 30 micron	Glossy white for paint
Radiator (External surfaces)	Chemical / blast cleaning (Sa2½)	Epoxy base zinc primer 30-40 micron	Epoxy base Zinc primer Min 30-40 micron	Aliphatic Polyurethane(PU Paint) (min)50 micron	Min 110 micron	541 shade of IS:5
Radiator and pipes up to 80 NB (Internal surfaces)	Chemical cleaning if required	Hot oil proof low viscosity varnish or hot oil resistant non corrosive paint	--	--	--	Glossy white for paint

**Annexure– II**

**PROFORMA FOR STAGE INSPECTION OF DISTRIBUTION TRANSFORMERS**

**(A) GENERAL INFORMATION:**

1. Name of firm : M/s.
2. Order No. and Date :
3. Rating-wise quantity offered :
4. Details of offer
  - a) Rating
  - b) Quantity
  - c) Serial Numbers
5. Details of last stage inspected lot:
  - a) Total quantity inspected
  - b) Serial Numbers
  - c) Date of stage inspection
  - d) Quantity offered for final inspection of (a) above with date

**(B) Availability of material for offered quantity:**

Details to be filled in

**(C) Position of manufacturing stage of the offered quantity:**

- a) Complete tanked assembly
- b) Core and coil assembly ready
- c) Core assembled
- d) Coils ready for assembly
  - (i) HV Coils
  - (ii) LV Coils

**Note:** (i) A quantity of less than 100 Nos. shall not be entertained for stage inspection. If the awarded quantity is less than 100 Nos., then whole lot shall be offered in single lot.

- (ii) The stage inspection shall be carried out in case :-
  - (a) At least 25% quantity offered has been tanked and
  - (b) core coil assembly of further at least 30% of the quantity offered has been completed.
- (iii) Quantity offered for stage inspection should be offered for final inspection within 15 days from the date of issuance of clearance for stage inspection, otherwise stage inspection already cleared shall be liable for cancellation.



	(7) Whether top yoke is cut for LV connection.		
	(8) If yes, at 7 above, whether reinforcement is done.		
	(9) Size of Support Channels provided for Core base and bottom yoke (Single piece of channels are only acceptable) This will not be applicable for Amorphous core. For Amorphous core, core clamps with locking arrangement with tank base cover will be provided.  This will not be applicable for Amorphous core. For Amorphous core, core clamps with locking arrangement with tank base cover will be provided.		
	(10) Thickness of insulation provided between core base and support channel.		
	(11) core length (leg center to leg center)		
	(12) Window height		
	(13) Core height		
	(14) Core weight only (without channel setc.)		
<b>(E)</b>	<b>INSPECTION OF WINDING</b>		
	<b>(I) Winding material</b>		
	(1) Material used for		
	(a) HV winding		
	(b) LV winding		
	(2) Grade of material for		
	(a) HV winding		
	(b) LV winding		
	3) Test certificate of manufacturer (enclose copy) for winding material of:		
	(a) HV		



	(b) LV			
	<b>(II) CONSTRUCTIONAL DETAILS</b>			
	(1) Size of Cross Sectional area of			
	(a) HV winding			

	(b) LV winding			
	(2) Type of insulation for conductor of:			
	a) HV winding			
	(b) LV winding			
	(3) Diameter of wire used for delta formation (mm)			
	(4) Diameter of coils in:			
	a) LV winding			
	i) Internal dia (mm)			
	ii) Outer dia (mm)			
	b) HV winding			
	i) Internal dia (mm)			
	ii) Outer dia (mm)			
	(5) Current Density of winding material used for :			
	(a) HV			
	(b) LV			
	(6) Whether neutral formation on top.			
	(7) HV Coils/Phase			
	a) Number			
	b) Turns/coil			
	c) Total turns			
	(8) LV Coils/Phase			
	a) Number			
	b) Turns/coil			

	c) Total turns			
	(9) Method of HV Coil Joints			
	(10) Total weight of coil of			
	a) LV winding (kg)			
	b) HV winding (kg)			
<b>(F)</b>	<b>INSULATION MATERIALS :</b>			
	(I) <b>MATERIAL:</b>			
	1) Craft paper			
	a) Make			
	b) Thickness (mm)			
	c) Test Certificate of manufacturer (enclose copy)			
	2) Press Board			
	a) Make			
	b) Thickness (mm)			
	c) Test Certificate of manufacturer (enclose copy)			
	3) Material used for top and bottom yoke and insulation			
	(II) <b>Type and thickness of material used: (mm)</b>			
	a) Between core and LV			
	b) Spacers			
	c) Interlayer			
	d) Between HV and LV winding			
	e) Between phases			
	f) End insulation			
<b>(G)</b>	<b>CLEARANCES: (mm)</b>			
	(I) <b>Related to core and windings</b>			

	1) LV to Core (Radial) 2) Between HV and LV (Radial)			
	3) (i) Phase to phase between HV Conductor			

	(ii) Whether two Nos. Press Board each of minimum 1mm thick provided to cover the tie rods.			
	4) Thickness of locking spacers between LV coils (mm)			
	5) Axial wedges between HV and LV coils/phase (Nos.)			
	6) No. of radial spacers per phase			
	7) Size of duct between LV and HV winding (mm)			
	<b>(II) Between core-coil assembly and tank: (mm)</b>			
	1) Between winding and body:			
	a) Tank lengthwise			
	b) Tank Breadthwise			
	2) Clearance between top cover and top yoke upto 100 kVA and between top cover and top most live part of tap changings witch for 200 kVA and above.			
<b>(H)</b>	<b>TANK :</b> <b>(I) Constructional details:</b> 1) Rectangular shape 2) Thickness of sidewall (mm) 3) Thickness of top and bottom plate (mm) 4) Provision of slopping top cover towards HV bushing.			

	5) Tank internal dimensions (mm)			
	a) Length			
	b) Breadth			
	c) Height			
	(i) On LVside			
	(ii) On LVside			
	(II) <b>General details:</b>			
	1) Inside painted by varnish/oil corrosion resistant paint (please specify which type of coating done)			
	2) Gasket between top cover and tank			
	i) Material			
	ii) Thickness (mm)			
	iii) Jointing overlaps (mm)			
	3). Reinforcement of welded angle (specify size and No. of angle provided) on side walls of tank.			
	4) Provision of lifting lugs:			
	b) Whether lugs of 8 mm thick MS Plate provided			
	c) Whether reinforced by welded plates edge wise below the lug upto reinforcing angle of the tank done.			
	Pulling lug of MS Plate			
	a) Nos.			
	b) Thickness (mm)			
	c) Whether provided on breadth side or			
	6) Provision of air release plug			
	7) Provision of galvanized GI Nuts Bolt with 1 No. Plain and 1 No. spring washer.			
	8) Deformation of length wise side wall of tank when subject to:			
	a) Vacuum of (-) 0.7 kg/sqcm for 30 minutes.			

Sl. N	Particulars	As offered	As observed	Deviation and Remarks
	b) Pressure of 0.8kg/sqcm for 30 minutes.			
<b>(I)</b>	<b>RAIDATORS:</b>			
	1. Fin Radiators of 1.25 mm thick sheet			
	a) Dimension of each fin (LxBxT)			
	b) Fins per radiator			
	c) Total No. of radiators			
	2. Verification of manufacturer's test certificate regarding Heat dissipation (excluding To			
	3. Verification of position of radiator with respect to bushing.			
<b>(J)</b>	<b>CONSERVATOR:</b>			
	1. Dimensions (L x D) (in mm)			
	2. Volume (m <sup>3</sup> )			
	3. Inside dia of Conservator tank			
	4. Whether conservator outlet pipe is projected approx. 20mm			
	5. Whether arrangement made so that oil does not fall on			
	6. Whether die cast metal oil level gauge indicator having three positions at (-5°C, 30°C and			
	7. Whether drain plug and filling hole with cover is provided.			
	8. Inner side of the conservator Tank painted with-			
<b>(K)</b>	<b>BREATHER:</b>			
	1. Whether Die cast Aluminium body breather for silicagel provided.			
	2. Make			
	3. Capacity			

Sl.No (L)	Particulars <b>TERMINALS:</b>	As offered	As observed	Deviation and Remarks
	1. Material whether of Brass Rods/Tinned Copper.			
	a) HV			
	b) LV			
	2. Size (dia in mm)			
	a) HV			
	b) LV			
	3. Method of Star connection formed on LV side of 6mm thick (Should use Al./Cu. Flat bolted/ brazed with crimped lug on winding alternatively for 63 and 100 kVA ratings brazing is done covered with tubular sleeve duly crimped).			
	4. Method of Connection of LV winding to LV Bushing (end of windings should be crimped with lugs (Al/Cu) and bolted with			
	5. Method of Connection of HV winding to HV bushing (Copper joints should be done by using silver brazing alloy and for Aluminium, brazing rod or with tubular connector crimped			
	6. Whether SRB tube/insulated paper used for formation of Delta on HV.			
	7. Whether Empire sleeves used on the portion of HV winding joining to HV bushing.			
	8. Whether neutral formation is covered with cotton tape			
	3. Whether arrangement for studs for fitting of HV Bushing are in diamond shape (so that Arcing Horns are placed vertically).			
	4. Position of mounting of LV bushings.			
	5. Bushing Clearance: (mm)			
	a) LV to Earth			

	b) HV to Earth			
	c) Between LV Bushings			
	d) Between HV Bushings			
<b>(N)</b>	<b>TANK BASE CHANNEL / ROLLERS:</b>			
	1. Size of channel (mm)			
	2. Whether channels welded across the length of the tank			
	3. Size and type of roller (mm)			
<b>(O)</b>	<b>OIL :</b>			
	1. Name of supplier			
	2. Breakdown voltage of oil: (kV)			
	i) Filled in tanked transformer			
	ii) In storage tank (to be tested by Inspecting Officer).			
	3. Supplier's test certificate (enclose copy)			
<b>(P)</b>	<b>ENGRAVING:</b>			
	1. Engraving / punching Sl. No. and name of firm on top channel / clamp or on separate plate which is firmly welded to the top channel / clamp.			
	i) On bottom of clamping channel of core-coil assembly.			
	ii) Engraving of Sl. No. and name of firm on side wall and top cover of tank along with date of dispatch.			
<b>(Q)</b>	i) MS plate of size 125x125 mm welded on width side of stiffener			
	ii) Following details engraved (as per approved GTP):			
	(a) Serial Number			
	(b) Name of firm			
	(c) Order No. and Date			
	(d) Rating			
	(e) Name of Inspecting Officer			
	(f) Designation			
	(g) Date of dispatch			
<b>(R)</b>	<b>NAME PLATE DETAILS:</b>			
	Whether Name Plate is as per approved drawing			
<b>(S)</b>	<b>Colour of Transformer</b>			
	1. Tank body colour shall be as per Annexure-Paint which is attached herewith			
	2. Conservator colour shall be as per Annexure-Paint which is attached herewith .			
<b>(T)</b>	<b>CHECKING OF TESTING FACILITIES:</b>			
	(Calibration certificate also to be checked for its validity)			
	<b>TESTS:</b>			
	1. No Load Current			
	2. No Load Loss			
	3. % Impedance			
	4. Load Losses			
	5. Insulation Resistance Test			

	6.Vector Group Test(phaserelationship)			
	7.RatioandPolaritytestrelationship			
	8. TransformerOilTest(Break Down Voltage)			
	9.Magnetic Balance			
	10. Measurementofwinding resistance(HVandLVboth)			
	11.Inducedovervoltagewithstandtest (DoublevoltageandDoublefrequency)			
	12.Separatesourcepowerfrequency withstandtestat28kVforHVand3kVforLV(oneminute).			
	13. Airpressure/Oil leakage Test			
	14.Vacuumtest			
	15.Unbalancedcurrenttest			
	16.Temperaturerise(HeatRun)test.			
<b>(U)</b>	We have specificallycheckedthefollowing and foundthesameas per G.T.P./deviationsobserved as			
	i) Rustlessnessof CRGO laminations used			
	ii)Core steps			
	iii) Core area			
	iv)Core weight			
	v) Winding crosssectionalarea			
	a)LV			
	b) HV			
	vi) Weightofwindings			
	vii)Clearancebetweenwindingandwallof tank(mm)			
	a)Length-wise			
	b) Breadth-wise			
	viii)Clearancebetweentopofyoke/topmostlivepartoftapchangertotankcover.			
	ix)DetailsofNeutralformation			
	x) Connections tobushings:			
	a)LV			
	b) HV			
	xi) Slopeoftanktop			
	xii)Positionofmountingofbushings			



**Annexure - A**

**Check-list for Inspection of Prime quality CRGO for Transformers**

During inspection of PRIME CRGO, the following points needs to be checked by the Transformer manufacturer. Utility's inspector shall verify all these points during inspection:-

iii) **In case PRIME CRGO cutting is at works of Transformer Manufacturer:**

Review of documents:

Purchase Order (unpriced) to PRIME CRGO supplier/Authorised Agency  
 Manufacturer's test certificate

Invoice of the Supplier

Packing List

Bill of Lading

Bill of Entry Certificate by Customs Deptt.

Reconciliation Statement as per format below  
 Certificate of Origin  
 BIS Certification

**Format for Reconciliation/Traceability records**

Packing List No./date /Quantity of PRIME CRGO received

Name of Manufacturer

Manufacturer test certificate No./date

Serial No.	Details of package/job	Drawing Reference	Quantity Involved	Cumulative Quantity Consumed	Balance stock

.1 Inspection of PRIME CRGO Coils:

PRIME CRGO-Manufacturer's Identification Slip on PRIME CRGO Coils

**Visual Inspection of PRIME CRGO Coils offered as per packing list ( for verification of coil details as per Test certificate & healthiness of packaging).**

**Unique numbering inside of each sample of PRIME CRGO coil and verification of records to be maintained in the register for consumption of CRGO coil.**

**ISI logo sticker on packed mother coil and ISI logo in Material TC.**

2.2. During inspection of PRIME CRGO, surveillance testing of sample shall be carried out for Stacking Factor, Permeability, Specific watt loss at 1.5 Tesla and/or 1.7 Tesla depending on the grade of PRIME CRGO and aging test etc. applicable as per relevant IS/ IEC standard, Tech. Spec., MQP and Transformer manufacturer plant standard.

**Inspection Clearance Report would be issued after this inspection**

3. Inspection of PRIME CRGO laminations: Transformer manufacturer will maintain records for traceability of laminations to prime CRGO coils and burr/bow on laminations shall be measured. Utility can review these records on surveillance basis.

4. Inspection at the time of core building:

Visual Inspection of PRIME CRGO laminations. In case of suspected mix-up/ rusting/decoloration, samples may be taken for testing on surveillance basis for tests mentioned in A.2.2 above.

Above tests shall be witnessed by Utility. In case testing facilities are not available at Manufacturer's work, the sample(s) sealed by Utility to be sent to approved labs for testing.

**Inspection Clearance Report would be issued after this inspection**

**(iii) In case PRIME CRGO cutting is at Sub-vendor of Transformer Manufacturer:**

Review of documents:

Purchase Order (unpriced) to PRIME CRGO supplier/ Authorised Agency

Purchase Order (unpriced) to Core Cutter

Manufacturer test certificate

Invoice of the Supplier

Packing List

Bill of Lading

Bill of Entry Certificate by Customs Deptt.

Reconciliation Statement as per format below

Certificate of origin

BIS Certification

**Format for Traceability records as below:-**

Packing List No./date /Quantity of PRIME CRGO received

Name of Manufacturer

Manufacturer test certificate No./date

Serial No.	Name of Customer	Details of package/job	Drawing Reference	Quantity Involved	Cumulative Quantity Consumed	Balance stock	Dispatch Details

1. Inspection of PRIME CRGO Coils:

PRIME CRGO-Manufacturer's Identification Slip on PRIME CRGO Coils

**Visual Inspection of PRIME CRGO Coils offered as per packing list ( for verification of coil details as per Test certificate & healthiness of packaging).**

**Unique numbering inside of each sample of PRIME CRGO coil and verification of records to be maintained in the register for consumption of CRGO coil.**

**ISI logo sticker on packed mother coil and ISI logo in Material TC.**

2.2. During inspection of PRIME CRGO, surveillance testing of sample shall be carried out for Stacking Factor, Permeability, Specific watt loss at 1.5 Tesla and/or 1.7 Tesla, thickness depending on the

grade of PRIME CRGO and aging test etc. applicable as per relevant IS/ IEC standard, Tech. Spec., MQP and Transformer manufacturer plant standard.

**Inspection Clearance Report would be issued after this inspection**

3 Inspection of PRIME CRGO laminations:

Transformer manufacturer representative will inspect laminations and issue their internal Inspection Clearance Report. Inspection will comprise of review of traceability to prime CRGO coils, visual Inspection of PRIME CRGO laminations and record of burr/bow. After clearance given by transformer manufacturer, Utility will issue an Inspection Clearance Report after record review. If so desired by Utility, their representative may also join transformer manufacturer representative during this inspection.

**Inspection Clearance Report would be issued after this inspection**

viii) Inspection at the time of core building:

Visual Inspection of PRIME CRGO laminations. In case of suspected mix-up/rusting/decoloration, samples may be taken for testing on surveillance basis for tests mentioned in B.2.2.

**Inspection Clearance Report would be issued after this inspection**

**NOTE :-**

a) Transformer Manufacturer to ensure that PRIME CRGO is procured from POWERGRID approved vendors and CRGO manufacturer should have valid BIS Certificate for respective offered Grade.

14.3 Transformer Manufacturer should also involve themselves for ensuring the quality of CRGO laminations at their Core Cutter's works. They should visit the works of their Core cutter and carry out necessary checks.

**c) General**

If a surveillance sample is drawn and sent to TPL (if testing facility not available with the manufacturer), the Transformer manufacturer can continue manufacturing at their own risk and cost pending TPL test report on PRIME CRGO sample drawn. Decision for acceptance of PRIME CRGO shall be based upon report of the sample drawn.

**These checks shall be read in-conjunction with approved Quality Plan, specification as a whole and conditions of contract.**

**Sampling Plan (PRIME CRGO)**

33 / 11 kV	-1 <sup>st</sup> transformer and subsequently at random 10% of Transformers (min. 1) offered for inspection.
DTs and other ratings	-1 <sup>st</sup> transformer and subsequently at random 2% of Transformers (min. 1) offered for inspection.

**NOTE:-** One sample for each lot of CRGO shall be drawn on surveillance basis.

CRGO has to be procured only from POWERGRID approved vendors. List of such vendors is available at the following website. Since the list is dynamic in nature, the site may be checked from time to time to see the list of approved vendors.

<http://apps.powergridindia.com/ims/ComponentList/Power-former%20upto%20420%20kV-CM%20List.pdf>

**1. ACSR CONDUCTOR**

**1. SCOPE**

This section covers design, manufacture, testing before dispatch, packing, supply and delivery for destination of Kms of ACSR Squirrel, Weasel, Rabbit", Raccoon, Dog and Panther Conductor.

**2. STANDARDS**

The Conductor shall also comply in all respects with the IS:398(Part-II)-1996 with latest amendments unless otherwise stipulated in this specification or any other International Standards which ensure equal or higher quality material.

The ACSR Conductor shall also conform to the following standards.

Sl. No.	Indian Standards	Title	International
1	IS:209-1979	Specification for Zinc	BS-3436-1961
2	IS:398-1996 Part-II	Specification for aluminum conductors for overhead transmission purposes.	
		Aluminum conductors	IEC-209-1966
		Galvanized steel reinforced	BS-215(Part-II)
3	IS:1521-1972	Method of Tensile Testing of Steel wire	ISO/R89-1959
4	IS:1778-1980	Reels and Drums for Bare conductors	BS-1559-1949
5	IS:1841-1978	E.C. Grade Aluminum rod produced by rolling	
6	IS:2629-1966	Recommended practice for Hot Dip Galvanizing of iron and steel	
7	IS:2633-1986	Method of testing uniformity of coating of zinc coated articles.	
8	IS:4826-1968	Galvanized coatings on round steel wires.	ASTMA472-729
9	IS:5484-1978	E.C. Grade Aluminium rod produced by continuous casting and rolling.	
10	IS:6745-1972	Methods of determination of weight of zinc-coating of zinc coated iron and steel articles	BS-443-1969

Offers conforming to standards other than IS-398 shall be accompanied by the English version of relevant standards in support of the guaranteed technical particulars to be furnished as per format enclosed.

**3. GENERAL TECHNICAL REQUIREMENTS**

The General Technical Requirements are given in Section-II. The Conductor shall conform to these technical requirements.

The Bidders shall furnish guaranteed technical particulars in Section-III.

**3.1. MATERIALS/WORKMANSHIP**

3.1.1. The material offered shall be of best quality and workmanship. The steel cored aluminum conductor strands shall consist of hard drawn aluminium wire manufactured from not less than 99.5% pure electrolytic aluminium rod of E.C. grade and copper content not exceeding 0.04%. They shall have the same properties and characteristics as prescribed in IEC:889-1987. The steel wire shall be made from material produced either by the acid or basic open hearth process or by electric furnace process or basic oxygen process. Steel wire drawn from Bessemer process shall not be used.

3.1.2. The steel wire shall be evenly and uniformly coated with electrolytic high grade, 99.95% purity zinc complying with the latest issue of IS-209 for zinc. The uniformity of zinc coating and the weight of coatings shall be in accordance with Section

n-II and shall be tested and determined according to the latest IS-2633 or any other authoritative standard.

- 3.1.3. The steel strands shall be hot dip galvanized as per IS: 4826. The coating shall be smooth, continuous, and of uniform thickness, free from imperfections and shall withstand minimum three dips after stranding in standard prece test. The steel strands shall be preformed and postformed in order to prevent spreading of strands in the event of cutting of composite core wire. The properties and characteristics of finished strands and individual wires shall be as prescribed in IEC: 888- 1987. If tested after stranding, reference shall also be made to cl. 4.1.1 and cl. 4.2.3 of IS : 4826.

**4. CONDUCTOR PARAMETERS**

The Parameters of individual strands and composite steel cored aluminum conductor, shall be in accordance with the values given in Section-II.

Creep in a conductor is attributed partly due to settlement of strands and partly due to non-elastic elongation of metal when subjected to load. The manufacturer of conductor shall furnish the amount of creep which will take place in 10, 20, 30, 40 and 50 years along with the supporting calculations. The calculations should be based on every day temperature of 32 °C and every day tension of 25% of UTS of conductor of 11/33 KV Lines.

**5. TOLERANCES**

The tolerances on standard diameter of Aluminum and Steel wires shall be as detailed in specific technical requirements.

The cross-section of any wire shall not depart from circularity by more than an amount corresponding to the tolerance on the standard diameter.

The details of diameters, lay ratios of Aluminum and steel wires shall be in accordance with the Section-II "Technical Requirements".

**6. SURFACE CONDITIONS**

All aluminum and steel strands shall be smooth, and free from all imperfections, spills and splits. The finished conductor shall be smooth, compact, uniform and free from all imperfections including spill and splits, die marks, scratches, abrasions, scuff marks, kinks (protrusion of wires), dents, press marks, cut marks, wire cross-over, over-riding looseness, pressure and/or unusual bang noise on tapping, material inclusions, white rust, powder formation or black spots (on account of reaction with trapped rain water etc.), dirt, grit, etc. The surface of conductor shall be free from points, sharp edges, abrasions or other departures from smoothness or uniformity of surface contour that would increase radio interference and coronal losses. When subjected to tension up to 50% of the ultimate strength of the conductor, the surface shall not depart from the cylindrical form nor any part of the component parts or strands move relative to each other in such a way as to get out of place and disturb the longitudinal smoothness of the conductor.

**7. JOINTS IN WIRES**

**7.1. Aluminum wires**

During stranding, no aluminum wire welds shall be made for the purpose of achieving the required conductor length.

No joint shall be permitted in the individual aluminum wires in the outermost layer of the finished Conductor. However, joints in the 12 wire & 18 wire inner layer of the conductor are permitted but these joints shall be made by the cold pressure butt welding and shall be such that not two such joints shall be within 15 meters of each other in the complete stranded conductor.

**7.2. Steel wires**

There shall be no joints in finished steel wires forming the core of the steel reinforced aluminum conductor.

**8. STRANDING**

The wires used in construction of the stranded conductor, shall, before stranding, satisfy all requirements of IS-398 (Part-II) 1996.

In all constructions, the successive layers shall be stranded in opposed directions. The wires in each layer shall be evenly and closely stranded round the underlying wire or wires. The outer most layer of wires shall have a right hand lay. The lay ratio of the different layers shall be within the limits given under Section-II.

## **9. PACKING**

- 9.1. The conductor shall be supplied in non-returnable strong wooden drums provided with lagging of adequate strength constructed to protect the conductor against any damage and displacement during transit, storage and subsequent handling and stringing operations in the field. The drums shall generally conform to IS-1778-1980 and latest version except as otherwise specified hereinafter. The conductor drums shall be adequate to wind one or more standard length of 2500 meters of SQUIRREL/WEASEL/RABBIT/RACON/D/DOG/PANTHER ACSR conductor.
- 9.2. The drum shall be suitable for wheel mounting and for letting off the conductor under a minimum controlled tension of the order of 5KN. The conductor drum shall be provided with necessary clamping arrangements so as to be suitable for tension stringing of power conductor.
- 9.3. The bidder should submit their drawings of the conductor drums along with the bid. After placement of letter of intent the Manufacturer shall submit four copies of fully dimensioned drawing of the drum for Employer's approval. After getting approval from the Employer, Manufacturer shall submit 30 more copies of the approved drawings for further distribution and field use.
- 9.4. All wooden components shall be manufactured out of seasoned soft wood free from defects that may materially weaken the component parts of the drums. Preservative treatment for anti-termite/antifungus shall be applied to the entire drum with preservatives of a quality which is no harmful to the conductor.
- 9.5. All flanges shall be 2-ply construction with 64mm thickness. Each ply shall be nailed and clenched together at approximately 90 degrees. Nails shall be driven from the inside face of the flange, punched and then clenched on the outer face. Flange boards shall not be less than the nominal thickness by more than 2 mm. There shall not be less than 2 nails per board in each circle.
- 9.6. The wooden battens used for making the barrel of the conductor shall be of segmental type. These shall be nailed to the barrel supports with at least two nails. The battens shall be closely butted and shall provide a round barrel with smooth external surface. The edges of the battens shall be rounded or chamfered to avoid damage to the conductor.
- 9.7. Barrel studs shall be used for construction of drums. The flanges shall be holed and the barrel supports slotted to receive them. The barrel studs shall be threaded over a length on either end, sufficient to accommodate washers, spindle plates and nuts for fixing flanges at the required spacing.
- 9.8. Normally, the nuts on the studs shall stand protruded off the flanges. All the nails used on the inner surface of the flanges and the drum barrel shall be countersunk. The ends of the barrel shall generally be flushed with the top of the nuts.
- 9.9. The inner cheek of the flanges and drum barrel surfaces shall be painted with bitumen based paint.
- 9.10. Before reeling, card board or double corrugated or thick bituminized waterproof bamboo paper or HDPE sheet shall be secured to the drum barrel and inside of flanges of the drum by means of a suitable commercial adhesive material. The paper should be dried before use. After reeling the conductor the exposed surface of the outer layer of

conductor shall be wrapped with thin polythene sheet across the flanges to preserve the conductor from dirt, grit and damage during transportation and handling and also to prevent ingress of rain water during storage/transport.

- 9.11. A minimum space of 75mm shall be provided between the inner surface of the external protective lagging and outer layer of the conductor. Outside the protective lagging, there shall be a minimum of two binders consisting of hoop iron/galvanised steel wire. Each protective lagging shall have two recesses to accommodate the binders.
- 9.12. Each batten shall be securely nailed across grains as far as possible to the flange edges with at least 2 nails per end. The length of the nail shall not be less than twice the thickness of the battens. The nail shall not protrude above the general surface and shall not have exposed sharp edges or allow the batten to be released due to corrosion.
- 9.13. The conductor ends shall be properly sealed and secured with the help of U-nails on one side of the flanges.
- 9.14. Only standard lengths of conductors shall be wound on each drum. The method of flagging to be employed shall be clearly stated in the tender.
- 9.15. As an alternative to wood end drum Bidder may also supply the conductors in non-returnable painted steel drums. The painting shall conform to IS:9954-1981, reaffirmed in 1992. Wooden/steel drum will be treated at par for evaluation purpose and accordingly the Bidder should quote the package.

## **10. LABELLING AND MARKING**

The drum numbers shall be branded or gauged or stencilled into the flange. A narrow shall be marked on the sides of the drum, together with the words "Roll this way". Each drum shall have the following information provided on the outside of the flange stencilled with indelible ink.

- i) Manufacturer's name and address.
- ii) Contract/Specification number.
- iii) Size and type of conductor.
- iv) Net weight of the conductor.
- v) Gross weight of the conductor and drum.
- vi) Length of the conductor.
- vii) Position of the conductor end.
- viii) Drum and lot number.
- ix) Name and address of the consignee.
- x) Month and year of manufacture.
- xi) The drum may also be marked with standard specification as per which the conductor is manufactured.

## **11. STANDARD LENGTHS**

- 11.1. The standard length of the conductor shall be 2500 metres. A tolerance of plus or minus 5% on the standard length offered by the bidder shall be permitted. All lengths outside this limit of tolerance shall be treated as random lengths.
- 11.2. Random lengths will be accepted provided no length is less than 70% of the standard length and total quantity of such random lengths shall not be more than 10% of the total quantity order. When on one end a random length has been manufactured at any time, five (5) more individual lengths, each equivalent to the above random length with a tolerance of +/- 5% shall also be manufactured and all above six random lengths shall be dispatched in the same shipment. At any point, the cumulative quantity supplied including such random lengths shall not be more

than 12.5% of the total cumulative quantity supplied including such random lengths. However, the least 20% of the quantity ordered shall be supplied only in standard length as specified.

- 11.3. Bidders shall also indicate the maximum single length, above the standard length, he can manufacture in the guaranteed technical particulars of offer. This is required for special stretches like river crossing etc. The Employer reserves the right to place orders for the above lengths on the same terms and conditions applicable for the standard lengths during the pendency of the Contract.

## **12. QUALITY ASSURANCE PLAN**

A Quality Assurance Plan including customer hold points covering the manufacturing activities of the material shall be required to be submitted by the tenderer to the Employer along with the tender. The Quality Assurance Plan after the same is found acceptable, will be approved by the Employer.

The contractor shall follow the approved Quality Assurance Plan in true spirit. If desired by the Employer, he shall give access to all the documents and materials to satisfy the Employer that the Quality Assurance Plan is being properly followed.

## **13. TESTING**

### **13.1. SELECTION OF TEST SAMPLES FOR TYPE TESTS**

- 13.1.1. The samples shall be taken from a continuous length of conductor and subjected to all the tests specified in clause 14.

### **13.2. SELECTION OF TEST SAMPLES FOR ACCEPTANCE TESTS**

- 13.2.1. Before dispatch from the works individual wire and finished steel core aluminum conductor shall be subjected to the tests as specified in IS: 398 or any other authoritative standard.
- 13.2.2. Sample for individual wires for tests shall be taken before stranding from outer ends of not less than ten percent of the spools in the case of aluminum wire and ten percent of the wire coils in the case of steel wires. If samples are taken after stranding, they shall be obtained by cutting 1.2 meters from the outer ends of the finished conductor from not more than 10 percent of the finished reels.
- 13.2.3. The routine tests shall be same as acceptance test. The manufacturer will draw samples for routine tests as per Cl. 13.1.1 or 13.1.2 of IS: 398 (Part 2) and will maintain the record of routine tests for buyer's review. For acceptance tests, the sample shall be taken as per Cl. shall be as per Cl. 13.1.2 of IS: 398 (Part 2).

## **14. TESTS**

The following tests shall be carried out on sample/samples of conductor.

### **14.1 Type Tests**

- (i) Visual examination
- (ii) Measurement of diameters of individual aluminum and steel wires.
- (iii) Measurement of lay ratio of each layer
- (iv) Breaking load test
- (v) Ductility test
- (vi) Wrapping test
- (vii) Resistance test on aluminum wires.
- (viii) DC resistance Test on aluminum wires.
- (ix) Galvanizing test



- (x) Surface condition test
- (xi) StressStrain test
- (xii) Procedure qualification test on weldedjoint of Aluminum Strands.

**NOTE:-**The typetestreportsshallnotbeolderthanFIVEyearsandshallbevaliduptoexpiryof validity of offer.

Theaboveadditionallistsifnotconductedearlier,shallbedoneunderthesubjectproject packageatnoextracost.

#### 14.2 **AcceptancetestsandRoutinetests**

- (ii) Visual anddimensional checkondrum.
- (iii) Visualexamination
- (iv) Measurement of diameters of individualaluminum and steelwires.
- (v) Measurementof layratio ofeach layer
- (vi) Breaking loadtest
- (vii) Ductilitytest
- (viii) Wrappingtest
- (ix) Resistance testonaluminumwires.
- (x) DCresistanceTeston CompositeConductor.
- (xi) Galvanizing test

#### 14.3 **TestsDuringManufacture**

The followingtestsduringmanufacture shallbe carried out.

- (i) Chemicalanalysisof zincused for galvanising,
- (ii) Chemicalanalysis ofaluminumusedfor making aluminumstrands,
- (iii) Chemicalanalysisofsteelusedformaking steel strands,

#### 14.4 **Visualexamination**

The conductorshall be examinedvisually for good workmanshipand generalsurface finishoftheconductor.Theconductor drumsshallberewoundinthepresenceofInspectingOfficer.TheInspectorwillinitiallycheckforScratches,Jointsetc.,andthattheconductorshallgenerally conformtotherequirementsofthespecifications/IS398(Part-II)-1996.

#### 14.5 **MeasurementofdiametersofindividualAluminumandSteelWires.**

The diametersofindividualAluminumandSteelWiresshallbecheckedtoensurethatthey conformtotherequirementsofthisspecification.

#### 14.6 **Measurementoflay-ratios**

The lay-ratiosofeachlayeroftheconductorshallbemeasuredandcheckedtoensurethat theyconform tothe requirements ofthis specificationand IS:398 (Part-II)-1996.

#### 14.7 **Breakingloadtest**

- a) **Breakingloadtestoncompleteconductor.**

Circlesperpendiculartotheaxisoftheconductorshallbemarkedattwoplacesonasampleofcond uctorofminimum5mlengthbetweenfixingarrangementsuitablyfixedonatensiletestingmachi ne.The loadshallbeincreasedatasteadyrateupto50%ofminimumspecifiedUTSandheldforon

eminute. The circles drawn shall not be distorted due to relative movement of strands. Thereafter the load shall be increased at steady rate to 100% of UTS and held for one minute. The Conductors amples shall not fail during this period. The applied load shall then be increased until the failing load is reached and the value recorded.

**b) Breaking load test on individual aluminum and galvanized steel wires.**

This test shall be conducted on both Aluminum and Galvanized steel wires. The breaking load of one specimen cut from each of the samples taken shall be determined by means of suitable tensile testing machine. The load shall be applied gradually and the rate of separation of the jaws of the testing machine shall be not less than 25 mm/min. and not greater than 100 mm./min. The ultimate breaking load of the specimens shall be not less than the values specified in the Section-II.

**14.8 Ductility Test**

For the purpose of this test both torsion and elongation tests shall be carried out on galvanized steel wires only.

**14.9 Torsion Test**

One specimen cut from each of the samples taken shall be gripped in two places exactly 15 cms. apart. One of the pieces shall be made to revolve at a speed not exceeding one revolution per second and the other shall be capable of moving longitudinally to allow for contraction or expansion during testing. A small tensile load not exceeding 2 (two) percent of the breaking load of the wire shall be applied to the samples during testing. The test shall be continued until fracture occurs and the fracture shall show a smooth surface at right angle to the axis of the wire. After fracture, the specimen shall be free from helical splits. The samples shall with stand a number of twist equivalent to not less than 18 on length equal to 100 times the diameter. When twisted after stranding the number of complete twists before fracture occurs shall be not less than 16 on length equal to 100 times the diameter of the wire. In case test sample length is less or more than 100 times the stranded diameter of the strand, the minimum number of twists will be proportioned to the length and if number comes in the fraction then it will be rounded off to the next higher whole number. The fracture shall show a smooth surface at right angle to the axis of the wire.

**14.10 Elongation Test**

The elongation of one specimen cut from each of the samples taken shall be determined. The specimens shall be straightened by hand and an original gauge length of 200 mm. shall be marked on the wire. A tensile load shall be applied as described in 1.1.4.6.2.1 and the elongation shall be measured after the fractured ends have been fitted together. If the fracture occurs outside the gauge marks, or within 25 mm. of either mark and the required elongation is not obtained, the test shall be disregarded and another test conducted. When tested before stranding, the elongation shall be not less than 4 percent and when tested after stranding, the elongation shall be not less than 3.5 percent.

**14.11 Wrapping Test**

This test shall be conducted on both Aluminum and Galvanized steel wires.

**14.11.1 Aluminum wires**

One specimen cut from each of the samples of aluminum wire shall be wrapped round a wire of its own diameter to form a close helix of 8 turns. Six turns shall then be unwrapped and closely wrapped in the same direction as before. The wire shall not break or show any crack.

**14.11.2 Galvanized steel wires**

One specimen cut from each of the samples of galvanized steel wire taken shall be wrapped round and round of diameter equal to 4 times the wire diameter to form a close helix of 8 turns. Six turns shall then be unwrapped and again closely wrapped in the same direction as before. The wire shall not break.

**14.12 Resistance Test**

This test shall be conducted on aluminum wires only, conforming to procedure as per IEC:889. The electrical resistance of one specimen of aluminum wire cut from each of the sample taken shall be measured at ambient temperature. The measured resistances shall be corrected to the value corresponding to 20 degrees C. by means of following formula.

$$R_{20} = R_T \frac{1 + \alpha(T - 20)}{1 + \alpha(20 - 20)}$$

Where  
 $R_{20}$  = Resistance corrected at 20 degrees C.  
 $R_T$  = Resistance measured at T degrees C.  
 $\alpha$  = Constant temperature coefficient of resistance 0.004. T = Ambient temperature during measurement

This resistance calculated to 20 degrees C. shall be not more than the maximum value specified in section-II.

**14.13 Galvanizing Test**

This test shall be conducted on galvanized steel wires only. The uniformity of Zinc coating and the weight of coating shall be in accordance with IS4826-1979.

**14.14 Surface Condition Test**

A sample of the finished conductor for use in 11/33KV system having a minimum length of 5 meter with compression type dead end clamps compressed on both ends in such manner as to permit the conductor to take its normal straight line shape, shall be subjected to a tension of 50 percent of the UTS of the conductor. The surface shall not depart from its cylindrical shape nor shall the strands move relative to each other so as to get out of place or disturb the longitudinal smoothness of conductor. The measured diameter at any places shall be not less than the sum of the minimum specified diameters of the individual aluminum and steel strands as indicated in Section-II.

**14.15 Stress-Strain Test**

The test is contemplated only to collect the creep data of the conductor from the manufacturer. A sample of conductor of minimum 10 meters length shall be suitably compressed with dead end clamps. (applicable only for conductors of nominal aluminium area 100 sq. mm and above)

**15. TEST SET-UP**

- 15.1. The test samples shall be supported in a trough over its full length and the trough adjusted so that the conductor will not be lifted by more than 10 mm under tension. This shall be ascertained by actual measurement.
- 15.2. The distance between the clamp and the sleeve mouth shall be monitored with callipers during the test to ensure that, after the test, it does not change by more than 1 mm + 0.1 mm from the value before the test.
- 15.3. The conductor strain shall be evaluated from the measured displacements at the two ends of the gauge length of the sample. The gauge reference targets shall be attached to the clamps which lock the steel and aluminum wire together. Target plates may be used with dial gauges or displacement transducers and care shall be taken to position the plates perpendicular to the conductor. Twisting the conductor, lifting it and moving it from side-to-side by the maximum amount expected during the test should introduce no more than 0.3 mm error in the reading.

## **16. TEST LOADS FOR COMPLETE CONDUCTOR**

The loading conditions for repeated stress-strain tests for complete conductors shall be as follows:

- 16.1. 1 kN load shall be applied initially to straighten the conductor. The load shall be removed after straightening and then the strain gauges are to be set at zero tension.
- 16.2. For non-continuous stress-strain data, the strain readings at 1 kN intervals at low tensions and 5 kN intervals above 30% of UTS shall be recorded.

**Report of Committee A**

- 16.3. The samples shall be reloaded to 30% of UTS and held for 1 hour. Readings are to be noted after 5, 10, 15, 30, 45 and 60 minutes during the hold period. The load shall be released then after the hold period.
- 16.4. The samples shall be reloaded to 50% of UTS and held for 1 hour. Readings are to be noted after 5, 10, 15, 30, 45 and 60 minutes during the hold period. The load shall be released then after the hold period.
- 16.5. Reloading up to 70% of UTS shall be done and held for 1 hour. Readings are to be noted after 5, 10, 15, 30, 45 and 60 minutes. The load shall be released.
- 16.6. Reloading up to 85% of UTS shall be done and held for 1 hour. Readings are to be noted after 5, 10, 15, 30, 45 and 60 minutes and the load shall be released then.
- 16.7. Tension shall be applied again and shall be increased uniformly until the actual breaking strength is reached. Simultaneous readings of tension and elongations shall be recorded up to 90% of UTS at the intervals described under Clause 16.6.

**17. TEST LOADS FOR STEEL CORE ONLY (applicable only for conductors of nominal aluminum area 100 sq. mm and above)**

The loading conditions for repeated stress-strain tests for the steel core of ACSR shall be as follows:

- 17.1. The test shall consist of successive applications of load applied in a manner similar to that for the complete conductor at 30%, 50%, 70% and 85% of UTS.
- 17.2. The steel core shall be loaded until the elongation at the beginning of each hold period corresponds to that obtained on the complete conductor at 30%, 50%, 70% and 85% of UTS respectively.

**18. STRESS-STRAIN CURVES**

The design stress-strain curve shall be obtained by drawing a smooth curve through the 0.5 and 1 hour points at 30%, 50% and 70% of UTS loadings. The presence of any aluminum slack that can be related to any observed extrusion entering the span from the compression dead ends shall be removed from the lower ends of the design curves. Both the laboratory and standard stress-strain curves shall be submitted to the Employer along with test results. The stress-strain data obtained during the test shall be corrected to the standard temperature i.e. 20 deg.C.

**19. DC RESISTANCE TEST ON COMPOSITE CONDUCTOR**

On a conductor sample of minimum 5m length, two contact clamps shall be fixed with a pre-determined bolt torque. The resistance of the samples shall be measured by a Kelvin double bridge by placing the clamps initially zero meter and subsequently on a meter apart. The test shall be repeated at least five times and the average value recorded. The value obtained shall be corrected to the value at 20 deg.C as per clause no. 12.8 of IS: 398 (Part-II)-1982/1996. The corrected resistance value at 20 deg.C shall conform to the requirements of this specification.

**20. PROCEDURE QUALIFICATION TEST ON WELDED ALUMINUM STRANDS.**

**Report of Committee A**

Two Aluminum wires shall be welded as per the approved quality plan and shall be subjected to tensile load. The breaking strength of the welded joint of the wires shall not be less than the guaranteed breaking strength of individual strands.

**21. CHEMICAL ANALYSIS OF ALUMINUM AND STEEL**

Sample taken from the Aluminum and Steel ingots/coils/strands shall be chemically/spectrographically analyzed. The same shall be in conformity with the requirements stated in this specification.

**22. CHEMICAL ANALYSIS OF ZINC**

Sample taken from the zinc ingots shall be chemically/spectrographically analysed. The same shall be in conformity with the requirements stated in this specification.

**23. VISUAL AND DIMENSIONAL CHECK ON DRUMS**

The drums shall be visually and dimensionally checked to ensure that they conform to the requirements of this specification.

**24. REJECTION AND RETEST**

24.1. In case of failure in any type test, the Manufacturer is either required to manufacture fresh sample lot and repeat all the tests successfully once or repeat that particular type test three times successfully on the sample selected from the already manufactured lot at his own expenses. In case a fresh lot is manufactured for testing then the lot already manufactured shall be rejected.

24.2. If samples are taken for test after stranding and if any selected reel fails in the retest, the manufacturer may test each and every reel and submit them for further inspection. All rejected material shall be suitably marked and segregated.

**25. CHECKING AND VERIFICATION OF LENGTH OF CONDUCTOR**

The contractor should arrange for inspection by the representative of the Employer specially authorized for this purpose. At least 50% of the total number of drums of conductors subject to minimum of two taken at random should be checked to ascertain the length of conductor. Arrangements should be made available in the work of the manufacturer for transferring the conductor from one reel to another at the same time measuring the length of the conductor so transferred by means of a meter.

**26. ADDITIONAL TESTS**

The Employer reserves the right of having at his own expenses any other test(s) of reasonable nature carried out at Bidder's premises, at site, or in any other standard Laboratory in addition to the aforesaid type, acceptance and routine tests to satisfy himself that the materials comply with the specifications.

**27. TESTING EXPENSES**

27.1. The breakup of the testing charges for the type tests specified shall be indicated separately.

27.2. Bidders shall indicate the laboratories in which they propose to conduct the type test. They shall ensure that adequate facilities are available in the laboratories and the tests can be completed in these laboratories within the time schedule guaranteed by them.

27.3. The entire cost of testing for the acceptance and routine tests and tests during manufacture specified

**Report of Committee A**

ed herein shall be treated as included in the quoted unit price of the conductor, except for the expenses of the inspector/Employer's representative.

- 27.4. In case of failure in any type test, if repeat type tests are required to be conducted then all the expenses for deputation of Inspector/Employer's representatives shall be deducted from the contract price. Also if on receipt of the Manufacturer's notice of testing, the Employer's representative does not find 'plant' to be ready for testing, the expenses incurred by the Employer for deputations shall be deducted from contract price.

**28. TEST REPORTS**

- 28.1. Copies of type test reports shall be furnished in at least six copies along with one original. One copy will be returned duly certified by the Employer only after which the commercial production of the material shall start.
- 28.2. Record of Routine test reports shall be maintained by the Manufacturer at his works for periodic inspection by the Employer's representative.
- 28.3. Test certificates of Tests during manufacture shall be maintained by the Manufacturer. These shall be produced for verification as and when desired by the Employer.

**29. TEST FACILITIES**

The following additional test facilities shall be available at the Manufacturer's works:

- (i) Calibration of various testing and measuring equipment including tensile testing machine, resistance measurement facilities, burette, thermometer, barometer, etc.
- (ii) Standard resistance for calibration of resistance bridges.
- (iii) Finished Conductor shall be checked for length verification and surface finish on separate rewinding machine at reduced speed (variable from 8 to 16 meters per minute). The rewinding facilities shall have appropriate clutch system and be free of vibrations, jerk etc. with traversing facilities.

**30. INSPECTION**

- 30.1. The Employer's representatives shall, at all times, be entitled to have access to the works and all places of manufacture where conductor shall be manufactured and the representatives shall have full facilities for unrestricted inspection of the Bidder's works, raw materials and process of manufacture and conducting necessary tests as detailed herein.
- 30.2. The Bidder shall keep the Employer informed in advance of the time of starting and of the progress of manufacture of conductor in its various stages so that arrangements can be made for inspection.
- 30.3. The contractor will intimate the Employer about carrying out of the tests at least 45 days in advance of the scheduled date of tests during which the Employer will arrange to depute his representative/ to be present at the time of carrying out of the tests. Six (6) copies of the test reports shall be submitted.
- 30.4. No material shall be dispatched from its point of manufacture before it has been satisfactorily inspected and tested, unless the inspection is waived off by the employer in writing. In the later case also, the conductor shall be dispatched only after satisfactory testing for all tests specified herein has been completed and approved by the employer.

**Report of Committee A**

30.5. The acceptance of any quantity of materials shall in no way relieve the Bidder of any of his responsibilities for meeting all requirements of the specification, and shall not prevent subsequent rejection if such material is later found to be defective.

30.6. At least 50% of the total number of drums subject to minimum of two in any lot put up for inspection, shall be selected at random to ascertain the length of conductor by the following method:

"At the work of the manufacturer of the conductor, the conductor shall be transferred from one drum to another at the same time measuring its length with the help of a graduated pulley and Cyclometer. The difference in the average length thus obtained and as declared by the Bidder in the packing list shall be applied to all the drums if the conductor is found short during checking".

31. **SCHEDULE OF DEVIATIONS / VARIATIONS**

If the tenderer has any exception to any of the clause/s laid down in this specification, these should be clearly stated in the schedule of deviations / variations.

**SECTION-II SPECIFIC TECHNICAL REQUIREMENTS SCOPE**

This section of the specification covers climatic and isoceraunic conditions, specific technical particulars, schedule of requirements & desired deliveries, for conductor for 11/33 kV lines.

**1. CLIMATIC & ISOCERAUNIC CONDITIONS TO BE SPECIFIED BY EMPLOYER**

1.11 Maximum Temperature

a) Conductor °C.

1.22 Minimum Temperature °C.

1.3 i) Max. ambient temperature °C

ii) Mean annual / everyday temperature °C 2.4 Basic wind speed m/s

2.5 Relative humidity

i) Maximum %

ii) Minimum %

2.6 Average Rainfall (Max.) mm per annum

2.7 a) Rainy months May to Sept.

15 Rainy days in a year (days)

2.8 Average number of thunderstorm

2.9 Altitude varying from sea level

2.10 Basic horizontal Seismic Co-efficient (horizontal) Basic vertical Seismic Co-efficient

2.11 System Particulars



## Report of Committee A

- a) Line Voltage (kV)
- b) Highest System Voltage (kV)
- c) Number of Circuits
- d) Frequency HZ
- e) Neutral
- f) Short circuit level (KA)

## 2. SPECIFIC TECHNICAL REQUIREMENTS

<b>CONDUCTOR:</b>					
1. Conductor:	Rabbit/Raccoon/Dog/Weasel/Panther ACSR				
2. IS applicable:	IS-398 (part-II) 1996 latest revision				
3. Wire Diameter	<b>Rabbit</b>	<b>Raccoon</b>	<b>Dog</b>	<b>Weasel</b>	<b>Panther</b>
Aluminium (mm)	6/3.35	6/4.06	6/4.72	6/2.59	30/3.00
Steel (mm)	1/3.35	1/4.09	7/1.57	1/2.59	7/3.00
4. Number of strands:					
Steel centre		1	1	1	1
1st steel layer	-		6		6
1st Aluminium layer	6	6	6	6	12
2nd Aluminium layer					18
5. Sectional Area of Aluminium (sq.mm.)	52.88	78.83	105	31.61	212.1
6. Total Sectional Area (sq.mm.)	61.7	91.97	118.5	36.88	261.5
7. Overall diameter (mm)	10.05	12.27	14.15	7.77	21

## Report of Committee A

8. Approximate weight (Kg./Km.)	10.05	12.27	14.15	7.77	21
9. Calculated D.C resistance at 20 degrees C., maximum. (Ohms/Km)	0.552	4.371	2.2792	0.9289	0.139
10. Ultimate tensile strength (KN)	18.25	26.91	32.41	11.12	89.67
11. Final modulus of elasticity (GN/sq.m)	79	79	75	79	80
12. Coefficient of linear expansion x10 <sup>-6</sup> per °C	19.1	19.1	19.8	19.1	17.8
13. Lay ratio	MaxMin	MaxMin	MaxMin	MaxMin	MaxMin
Steel core 6 wire layer			28 13		28 13
Aluminium 1st layer	14 10	14 10	14 10	14 10	14 10
2 <sup>nd</sup> layer					16 10

## 14. Technical Particulars

a. Diameter-mm	<b>Rabbit</b>		<b>Raccon</b>		<b>Dog</b>		<b>Weasel</b>		<b>Panther</b>	
	<b>Al</b>	<b>Steel</b>	<b>Al</b>	<b>Steel</b>	<b>Al</b>	<b>Steel</b>	<b>Al</b>	<b>Steel</b>	<b>Al</b>	<b>Steel</b>
Standard (mm)	3.35	3.35	4.09	4.09	1.57	4.72	2.59	2.59	3.00	3.00
Maximum (mm)	3.42	3.38	4.17	4.13	1.60	4.77	2.64	2.62	3.06	3.03
Minimum (mm)	3.28	3.32	4.01	4.05	1.54	4.67	2.54	2.56	2.94	2.97
b. Cross-sectional area of nominal diameter wire (mm <sup>2</sup> )	8.814	13.14	13.14	1.93	17.50	5.269	5.269	7.069	7.069	

## Report of Committee A

c. Weight(Kg./Km)	68.75	23.82	102.48	35.51	15.10	47.30	41.09	14.24	55.13	19.11
d. Min. breaking load (KN) Before stranding	11.58	1.43	17.27	2.08	2.70	2.78	6.92	0.89	9.29	1.17
After Stranding	11.00	1.36	16.4	1.98	2.57	2.64	6.57	0.85	8.83	1.11
e. D. Resistance at 20°C min (Ohm/Km)	-3.265		-2.194		1.65		-5.49			

## 15. Zinc coating of steel core:

- (i) The steel strands shall be hot dip galvanized as per IS: 4826.
- (ii) Process of Galvanizing: Hot dip.
- (iii) Quality of Zinc : IS-209/1979 or latest edition.

## 16. Joints in strands

16.1 Steel : Not permitted

16.2 **Aluminium:** No joints shall be permitted in the Aluminium wires in the outermost layer of the AC SR conductor. But permitted in the inner layers such that not two such joints are within 15 meters of each other in the complete stranded conductor.

## 15. Chemical composition of high carbon steel wire:

Element	% Composition
i) Carbon	0.5 to 0.85
ii) Manganese	0.5 to 1.10
iii) Phosphorus	Not more than 0.035
iv) Sulphur	Not more than 0.045
v) Silicon	0.10 to 0.35

## 2. AAA CONDUCTOR

### 1.1 TECHNICAL DESCRIPTION OF AAA CONDUCTOR

#### DETAILS OF CONDUCTORS

1.1.1 The AAAC Conductor shall generally conform to IS: 398 (Part-IV), IEC: 104-1987 except where otherwise specified herein.

1.1.2 The details of the AAAC Conductor of various sizes are given in the enclosed Table-I

### 1.2 WORKMANSHIP

1.2.1 All the Al-

alloy strands shall be smooth, uniform and free from all imperfections, such as spills and splits, dimarks, scratches, abrasions, etc., after drawing and also after stranding.

1.2.2 The finished conductors shall be smooth, compact, uniform and free from all imperfections including kinks (protrusion of wires), scuff marks, dents, press marks, cut marks, wire crossover, overriding, looseness (wire being dislocated by finger/hand pressure and/or unusual bang noise on tapping), material inclusions, white rust, powder formation or black spot (on account of reaction with trapped rain water etc.), dirt, grit etc.

### 1.3 JOINTS IN WIRES

1.3.1 1 No joint shall be permitted in any layer of finished conductor.

### 1.4 STRANDING

In all constructions, the successive layers shall be stranded in opposite directions. The wires in each layer shall be evenly and closely stranded round the underlying wire or wires. The outermost layer of wires shall have a right hand lay. The lay ratios shall be as follow.

Number of wires in conductor	3/6 Wire layer		12 Wire layer		18 Wire layer	
	Min	Max	Min	Max	Min	Max
3	10	14	=	=	=	=
7	10	14	=	=	=	=
19	10	16	10	14	=	=
37	10	17	10	16	10	14

### 1.5 TOLERANCES

The manufacturing tolerances in diameter of individual aluminium alloy strand shall be as per **Table-I**.

### 1.6 MATERIALS

#### 1.6.1 ALUMINUM ALLOY

The wire shall be of heat treated aluminum, magnesium silicon alloy having a composition appropriate to the mechanical & electrical properties as specified in IS 398 (Part-4).

The Aluminum Alloy strands drawn from heat treated aluminium alloy redraw rods conforming to Type B as per IEC:104-latest amendment. The chemical composition conform to of redrawn rods shall IS 1997-91, as given below:

<i>Elements</i>	<i>Percent</i>
Si	0.50-0.90
Mg	0.60-0.90
Fe	0.50 max
Cu	0.10 max
Mn	0.03 max
Cr	0.03 max
Zn	0.10 max
B	0.06 max
Other Element (Each)	0.03 max
Other Element (Total)	0.10 max
Al	Remainder

## 1.7

### **STANDARD LENGTH**

#### 1.7.1

The standard length of the conductor shall be 2000 meters. A tolerance of +/-5% on the standard length offered by the Bidder shall be permitted. All lengths outside this limit of tolerance shall be treated as random lengths. The conductor drums shall be adequate to wind one or more standard length of 2000 meters of SQUIRREL/WEASEL/RABBIT/RACON/DOG/ PANTHER AAA conductor.

#### 1.7.2

Random lengths will be accepted provided no length is less than 70% of the standard length and the total quantity of such random lengths shall not be more than 10% of the total quantity ordered.

#### 1.7.3

Bidders shall also indicate the maximum single length, above the standard length, he can manufacture in the guaranteed technical particulars offered. The Owner reserves the right to place orders for the above lengths on the same terms and conditions applicable for the standard lengths during the execution of the Contract.

## 1.8

### **TESTS AND STANDARDS**

The following tests to be conducted for AAAC conductors shall conform to IS 398 (Part-IV) 1979 and IEC 888 & 889.

1.8.1

**TYPE/PERIODIC**

The following tests shall be conducted on samples of each type of conductor :

- a) UTS test on stranded conductor )  
 )  
 ) Annexure-A
- (b) DC resistance test on stranded conductor )  
 )

1.8.2

**ACCEPTANCE TESTS**

- (a) Visual check for joint scratches etc. and length measurement of conductor by rewinding )  
 ) Annexure -A
- (b) Dimensional check on Al-alloy strands )
- (c) Check for lay-ratio )  
 )
- (d) Elongation test )  
 ) Annexure-A
- (e) Breaking load/tensile test on )  
 ) Aluminum alloy strands )
- (f) DC resistance test on )  
 ) Aluminum alloy strands )
- (g) Wrap test on )  
 ) 104, IEC 1089 Aluminum alloy strands IEC
- (h) Visual and dimensional check on drum )  
 ) IS:1778-1980

1.8.3

**ROUTINE TEST**

- (a) Check to ensure that there are no joints.

- (b) Check that there are no cuts, fins etc. on the strands.
- (c) Check that drums are as per Specification.
- (d) All acceptance tests as mentioned above to be carried out on each coil.

1.8.4

**TESTS DURING MANUFACTURE**

- (a) Chemical analysis of

Aluminum alloy used for making strands )  
 ) Annexure-A

1.8.5

**TESTING EXPENSES**

- i) The type test charges for the conductor should be quoted in the relevant schedule of Bid Proposal Sheets.
- ii) Contractor shall indicate the laboratories in which they propose to conduct the type tests. They shall ensure that adequate facilities are available in the laboratories and the tests can be completed in these laboratories within the time schedule guaranteed by them.
- iii) In case of failure in any type test, the Contractor is either required to manufacture fresh sample lot and repeat all the tests successfully once or repeat that particular type test three times successfully on the sample selected from the already manufactured lot at his own expenses. In case a fresh lot is manufactured for testing, then the lot already manufactured shall be rejected.
- iv) The entire cost of testing for the acceptance and routine tests and Tests during manufacture specified herein shall be treated as included in the quoted unit price of conductor, except for the expenses of the Inspector/Owner's representative.
- v) In case of failure in any type test, if repeat type tests are required to be conducted, then all the expenses for deputation of Inspector/Owner's representative shall be deducted from the contract price. Also if on receipt of the Contractor's notice of testing, the Owner's representative does not find the material or testing facilities to be ready for testing the expenses incurred by the Owner for re-deputations shall be deducted from contract price.

1.8.6

**ADDITIONAL TESTS**

- i) The Owner reserves the right of having at his own expenses any other test(s) of reasonable nature carried out at Contractor's

premises, at site or in any other place in addition to the aforesaid type, acceptance and routine tests to satisfy himself that the materials comply with the Specifications.

- ii) The Owner also reserves the right to conduct all the tests mentioned in this specification at his own expense on the samples drawn from the site at Contractor's premises or at any other test centre. In case of evidence of non-compliance, it shall be binding on the part of Contractor to prove the compliance of the item to the technical specifications by repeat tests, or correction of deficiencies, or replacement of defective items all without any extra cost to the Owner.

#### 1.8.7 **SAMPLE BATCH FORTYPE TESTING**

- i) The Contractor shall offer material for selection of samples for type testing only after getting Quality Assurance Plan approved from Owner's Quality Assurance Deptt. The samples shall be manufactured strictly in accordance with the Quality Assurance Plan approved by Owner.
- ii) The Contractor shall offer at least three drums for selection of sample required for conducting all the type tests.
- iii) The Contractor is required to carry out all the acceptance tests successfully in presence of Owner's representative before sample selection.

#### 1.8.8 **TEST REPORTS**

- i) Copies of type test reports shall be furnished in at least six copies along with one original. One copy will be returned duly certified by the Owner only after which the commercial production of the material shall start.
- ii) Record of routine test reports shall be maintained by the Supplier at this works for periodic inspection by the Owner's representative.
- iii) Test Certificates of tests during manufacture shall be maintained by the Contractor. These shall be produced for verification as and when desired by the Owner.

#### 1.9 **INSPECTION**

- 1.9.1 The Owner's representative shall at all times be entitled to have access to the works and all place of manufacture, where conductor shall be manufactured and representatives shall have full facilities for unrestricted inspection of the Contractor's works, raw materials and process of manufacture for conducting necessary tests as detailed herein.
- 1.9.2 The Contractor shall keep the Owner informed in advance of the time of starting and of the progress of manufacture of conductor in its various stages so that arrangements can be made for inspection.
- 1.9.3 No material shall be dispatched from its point of manufacture before it has been satisfactorily inspected and tested, unless the inspection is waived off by the Owner in writing. In the latter case also, the conductor shall be dispatched only after satisfactory testing for all tests specified herein have been completed.



1.9.4 The acceptance of any quantity of material shall in no way relieve the Contractor of any of his responsibilities for meeting all requirements of the Specification, and shall not prevent subsequent rejection if such material is later found to be defective.

1.9.5 **TEST FACILITIES**

The following additional test facilities shall be available at the Contractor's works:

- i) Calibration of various testing and measuring equipment including tensile testing machine, resistance measurement facilities, burette, thermometer, barometer etc.
- ii) Standard resistance for calibration of resistance bridges.
- iii) Finished conductor shall be checked for length verification and surface finish on separate rewinding machine at reduced speed (variable from 8 to 16 meters per minute). The rewinding facilities shall have appropriate clutch system and free of vibrations, jerk setc. with traverselaying facilities.

1.10 **PACKING**

1.10.1 The conductor shall be supplied in non-returnable, strong, wood drums provided with lagging of adequate strength, constructed to protect the conductor against any damage and displacement during transit, storage and subsequent handling and stringing operations in the field. The Contractor shall be responsible for any loss or damage during transportation handling and storage due to improper packing. The drum shall generally conform to IS: 1778-1980, except as otherwise specified hereinafter.

1.10.2 The drum shall be suitable for wheel mounting and for letting off the conductor under a minimum controlled tension of the order of 5KN.

1.10.3 The Contractor should submit their proposed drum drawings along with the bid.

1.10.4 The Contractor may offer more than one length of the conductor in a single drum.

1.10.5 All wooden components shall be manufactured out of seasoned softwood free from defects that may materially weaken the component parts of the drums. Preservative treatments shall be applied to the entire drum with preservatives of a quality, which is not harmful to the conductor.

1.10.6 The flanges shall be of two ply construction with a total thickness of 64mm with each ply at right angle to the adjacent ply and nailed together. The nail shall be driven from the inside face of the flange, punched and then clenched on the outer face. Flange boards shall not be less than the nominal thickness by more than 2mm. There shall not be less than 2 nails per board in each circle. Where a slot is cut in the flange to receive the inner end of the conductor the entrances shall be in line with the periphery of the barrel.

- 1.10.7 The wooden battens used for making the barrel of the conductor shall be of segmental type. The seshall be nailed to the barrel supports with at least two nails. The battens shall be closely butted and shall provide a round barrel with smooth external surface. The edges of the battens shall be rounded or chamfered to avoid damage to the conductor.
- 1.10.8 Barrel stud shall be used for the construction of drums. The flanges shall be holed and the barrel support slotted to receive them. The barrel stud shall be threaded over a length on either end, sufficient to accommodate washers, spindle plates and nuts for fixing flanges at the required spacing.
- 1.10.9 Normally, the nuts on the stud shall stand protruded of the flanges. All the nails used on the inner surface of the flanges and the drum barrel shall be countersunk. The ends of barrel shall generally be flushed with the top of the nuts.
- 1.10.10 The inner cheek of the flanges and drum barrel surface shall be painted with bitumen based paint.
- 1.10.11 Before reeling, card board or double corrugated or thick bituminous water-proof bamboo paper or HDPE sheet shall be secured to the drum barrel and inside of flanges of the drum by means of a suitable commercial adhesive material. The paper should be dried before use. After reeling the conductor the exposed surface of the outer layer of conductor shall be wrapped with thin polythene sheet across the flanges to preserve the conductor from dirt, grit and damage during transportation and handling and also to prevent ingress of rain water during storage/transport.
- 1.10.12 A minimum space of 75 mm for conductor shall be provided between the inner surface of the external protective lagging and outer layer of the conductor. Outside the protective lagging, there shall be minimum of two binders consisting of hoop iron/galvanized steel wire. Each protective lagging shall have two recesses to accommodate the binders.
- 1.10.13 Each batten shall be securely nailed across grains as far as possible to the flange, edges with at least 2 nails per end. The length of the nail shall not be less than twice the thickness of the battens. The nail shall not protrude above the general surface and shall not have exposed sharp, edges so as to allow the batten to be released due to corrosion.
- 1.10.14 The nuts on the barrel stud shall be tack welded on the one side in order to fully secure them. On the second end, a spring washer shall be used.
- 1.10.15 A steel collar shall be used to secure all barrel studs. This collar shall be located between the washer and the steel drum and secured to the central steel plate by welding.
- 1.10.16 Outside the protective lagging, there shall be minimum of two binder consisting of hoop iron/galvanized steel wire. Each protective lagging shall have two recesses to accommodate the binders.
- 1.10.17 The conductor ends shall be properly sealed and secured with the help of U-nail on the side of one of the flanges to avoid loosening of the conductor layers during transit and handling.
- 1.10.18 As an alternative to wood drum Contractor may also supply the conductors in non-returnable painted steel drums. After preparation of steel surface according to IS: 9954, synthetic enamel paint shall be applied after application of one coat of primer. Wooden/Steel drum will be treated at par for evaluation purpose and accordingly

the Contractor should quote in the package.

1.11

### **MARKING**

Each drum shall have the following information stenciled on it in indelible ink along with the essential data :

- a. Contract/Award letter number.
- b. Name and address of consignee.
- c. Manufacturer's name and address.
- d. Drum and lot number
- e. Size and type of conductor
- f. Length of conductor in meters
- g. Arrow marking for unwinding
- h. Position of the conductor ends
- i. Number of turns in the outermost layer.
- j. Gross weight of drum after putting lagging.
- k. Average weight of the drum without lagging.
- l. Net weight of the conductor in the drum.
- m. Month and year of manufacture of conductor

The above should be indicated in the packing list also.

1.12

### **VERIFICATION OF CONDUCTOR LENGTH**

The Owner reserves the right to verify the length of conductor after unreeiling at least Two (2) per cent of the drums in a lot offered for inspection.

For the balanced drums, length verifications shall be done by the owner based on report/certification from Manufacturer/Contractor.

1.13

### **STANDARDS**

1.13.1

The conductor shall conform to the following Indian/International Standards, which shall mean latest revisions, with amendments/changes adopted and published, unless specifically stated otherwise in the Specification.

1.13.2

In the event of the supply of conductor conforming to standards other than specified, the Bidder shall confirm in his bid that these standards are equivalent to those specified. In case of award, a list of features of comparison between the standards proposed by the Contractor and those specified in this document will be provided by the Contractor to establish their equivalence.

SL .NO.	Indian Standard	Title	International Standard
1	IS:398 (Part-IV)	Aluminum Alloy	IEC : 208-1966
		stranded conductor	BS-3242-1970
2	IS:9997-1988	Aluminum Alloy Redraw Rods	IEC 104-1987
3	IS:1778-1980 Reels	Reels and Drums for bare conductors	BS:1559-1949

**ANNEXURE-A****1.0 TESTS ON AAAC CONDUCTORS****1.1 UTS Test on Stranded Conductor**

Circles perpendicular to the axis of the conductor shall be marked at two places on a sample of conductor of minimum 5m length between fixing arrangements suitably fixed on a tensile testing machine. The load shall be increased at a steady rate up to 50% of minimum specified UTS and held for one minute. The circles drawn shall not be distorted due to relative movement of strands. Thereafter the load shall be increased at a steady rate to minimum UTS and held for one minute. The conductor samples shall not fail during this period. The applied load shall then be increased until the failing load is reached and the value recorded.

**1.2 D.C. Resistance Test on Stranded Conductor**

On a conductor sample of minimum 5m length two contact-clamps shall be fixed with a predetermined bolt torque. The resistance shall be measured by a Kelvin double bridge by placing the clamps initially zero meter and subsequently on a meter apart. The test shall be repeated at least five times and the average value recorded. The value obtained shall be corrected to the value at 20°C as per IS: 398-(Part-V)-1982. The resistance corrected at 20°C shall conform to the requirements of this Specification.

**1.3 CHEMICAL ANALYSIS OF ALUMINIUM ALLOY**

Sample taken from the Aluminium alloying ingots/coils/strands shall be chemically/spectrographically analyzed. The same shall be in conformity to the requirements stated in this Specification.

**1.4 VISUAL AND DIMENSIONAL CHECK ON DRUMS**

The drums shall be visually and dimensionally checked to ensure that they conform to the requirements of this Specification.

**1.5 VISUAL CHECK FOR JOINTS, SCRATCHES ETC.**

Conductor drums shall be rewound in the presence of the Owner. The Owner shall visually check for scratches, joints etc. and that the conductor generally conforms to the requirements of this Specification. **Two percent (2%)** drums from each lot shall be rewound in the presence of the Owner's representative.

**1.6 DIMENSIONAL CHECK ON ALUMINIUM ALLOY STRANDS**

The individual strands shall be dimensionally checked to ensure that they conform to the requirement of this Specification.

**1.7 CHECK FOR LAY-RATIOS OF VARIOUS LAYERS**

The lay-ratios of various layers shall be checked to ensure that they conform to the requirements of this Specification.

**1.8 TORSION AND ELONGATION TESTS ON ALUMINIUM ALLOY STRANDS**

The test procedure shall be as per clause No. 10.3 of IEC: 888. In torsion test, the number of complete twists before fracture shall not be less than 18 on a length equal to 100 times the standard diameter of the strand. In case test sample length is less or more than 100 times the stranded diameter of the strand, the minimum number of twists will be proportioned to the length and if number comes in the fraction then it will be rounded off to next higher whole number. In elongation test, the elongation of the strand shall not be less than 4% for a gauge length of 250mm.

1.9

**CHECK ON BARREL BATTEN STRENGTH OF DRUMS**

The details regarding barrel batten strength test will be discussed and mutually agreed to by the Contractor & Owner in the Quality Assurance Programme.

1.10

**Breaking Load Test on Individual Aluminium Alloy Wires**

The test shall be conducted on Aluminium alloy wires. The breaking load of one specimen cut from each of the samples taken shall be determined by means of suitable tensile testing machine. The load shall be applied gradually at the jaws of the testing machine shall be not less than 25 mm/min. and not greater than 100 mm./min. The ultimate breaking load of the specimens shall be not less than the values specified in the Specification.

1.11

**RESISTANCE TEST ON ALUMINUM ALLOY WIRE**

The test shall be conducted on aluminium alloy wires only, conforming to procedure as per IEC: 889. The electrical resistance of one specimen of aluminium wire cut from each of the samples taken shall be measured at ambient temperature. The measured resistances shall be corrected to the value corresponding to 20 degree C. by means of following formula.

$$R_{20} = R_T \frac{1}{1 + \alpha(T - 20)}$$

Where

$R_{20}$  = Resistance corrected at 20 degrees C.

$R_T$  = Resistance measured at T degrees C.

$\alpha$  = Constant mass temperature coefficient of resistance 0.004.

T = Ambient temperature during measurement

This resistance calculated to 20 degrees C. shall be not more than the maximum value specified in the specification.

## ReportofCommitteeA

**Table-1****DetailsofparametersofAAAconductor**

S.N	Parameter	Squirrel	Weasel	Rabbit	Raccon	DOG	wolf	Panther
1	Totalsection alarea ofconductor (sqmm)	22	34	55	80	100	173	232
2	(No of Alstrand/diai nmm)	7/2.00	7/2.50	7/3.15	7/3.81	7/4.26	19/3.40	19/3.94
3	Overalldia meter(mm )	6	7.5	9.45	11.43	12.78	17	19.7
4	approx mass(kg/km)	60.16	94	149.2	218.26	272.86	474.02	636.67
5	Resistanceat 20 degcel(ohms /km)	1.541	0.99	0.621	0.425	0.339	0.1969	0.1471
6	approxcalcul atedbreakin gload (kN)	6.45	10.11	16.03	23.41	29.26	50.54	68.05
7	Final modulus of Elasticity, GN/sqm (kg/sq cm)	0.6324 x 10 (pwr6)	0.6324 x 10	0.6324 x 10	0.6324 x 10	0.6324 x 10	0.612x1 0	0.612x1 0
8	Coefficient of linear Expansion/° C	23.0 X10 (pwr - 6)	23.0 X10	23.0 X10	23.0 X10	23.0 X10	23.0 X10	23.0 X10
9	Details ofAluminium							

S.N	Parameter	Squirrel	Weasel	Rabbit	Racco n	DOG	wolf	Panther
	Strands							
a	Minimum breaking load of the strand before stranding (kN)	0.97	1.52	2.41	3.52	4.4	2.8	3.77
b	Minimum breaking load of the strand after stranding (kN)	0.92	1.44	2.29	3.34	4.18	2.66	3.58
c	Maximum DC resistance of strands at 20deg C (ohms/km)	10.653	6.845	4.29	2.938	2.345	3.677	2.746
d	Mass (kg/km)	8.482	13.25	21.04	30.78	38.48	24.51	32.92
e	Diameter							
i	Nominal	2.0	2.50	3.15	3.81	4.26	3.40	3.94
ii	Maximum	2.02	2.53	3.18	3.85	4.30	3.43	3.98
iii	Minimum	1.98	2.47	3.12	3.77	4.22	3.37	3.90

**PCC Poles**

**As per State Practice.**



**2. Tubular Steel Poles for Overhead Lines**

**1 SCOPE:**

This specification covers the general requirements towards design, manufacture, testing at manufacturers works, supply and delivery for tubular steel poles of circular cross section ( swaged type ) for overhead lines.

**2 STANDARD:**

The tubular steel poles shall conform to the latest edition of Indian Standard specification IS: 2713 (Part – I, III): 1980 or any other authoritative standards (as amended up-to- date) except where specified otherwise in this specification.

**3 Topography and Climatic Condition:**

The materials offered, shall be suitable for operation in tropical climate and will be subjected to the sun and inclement weather and shall be able to withstand wide range of temperature variation. For the purpose of design, average atmospheric temperature may be considered to be 50°C with humidity nearing saturation.

**4 Materials:**

**4.1** The materials used in construction of tubular steel poles shall be of the tested quality of steels of minimum tensile strength 540 MPa (: 55 Kgf/mm<sup>2</sup>).

**4.2** The materials, when analysed in accordance with IS: 228 (Part-III: 1972) and IS : 228 ( Part-IX) shall not show sulphur and phosphorous contents of more than 0.060 percent each.

**5 Types, Size and construction:**

**5.1** Tubular Steel Poles shall be swaged type.

**5.2** Swaged poles shall be made of seamless or welded tubes of suitable lengths swaged and jointed together. No circumferential joints shall be permitted in the individual tube lengths of the poles. If welded tubes are used they shall have one longitudinal weld seam only: and the longitudinal welds shall be staggered at each swaged joint.

**5.3** Swaging may be done by any mechanical process. The upper edge of each joint shall be chamfered if at an angle of about 45°. The upper edge need not be chamfered if a circumferential weld is to be deposited in accordance with clause No. 5.3 2 of IS: 2713 ( Part-I):1980.

**5.4** The length of joints on swaged poles shall be in accordance with clause No. 5.4 of IS: 2713 (Par-I): 1980.

**5.5.** Poles shall be well-finished, clean and free from harmful surface defects. Ends of the poles shall be cut square. Poles shall be straight, smooth and cylindrical. The weld joints, if any, shall be of good quality, free from scale, surface defects, cracks, etc.

**5.6.** Tolerances for outside diameter, thickness, length, weight and straightness shall be in accordance with IS: 2713 (Part-I) : 1980.

- 5.7.** The poles shall be coated with black bituminous paint conforming to IS: 158-1968 throughout, internally and externally, upto the level which goes inside the earth. The remaining portion of the exterior shall be painted with one coat of red oxide primer as specified in IS: 2074-1979.

**6 Earthing Arrangements:**

For earthing arrangement a through hole of 14mm diameter shall be provided in each pole at a height of 300mm above the planting depth.

**7 Tests and Test Certificates:**

- 7.1** The following tests shall be conducted on finished poles :

- A. Tensile test and chemical analysis for sulphur and phosphorous,
- B. Deflocation test,
- C. Permanent set test, and
- D. Drop test.

- 7.2** In addition to above verification of dimensions as per IS: 2713 (Part-III) : 1980 shall be carried out during acceptance lots.

- 7.3** Number of poles selected for conducting different tests shall be in accordance to clause No. 10.1.1 and No. 10.1.12: of IS: 2713 (Part-I) 1980.

- 7.4** Tests shall be carried out before supply of each consignment at the manufacturers works and test certificates should be submitted to the purchaser for approval prior to delivery.

- 7.5** Re-tests, if any, shall be made in accordance with IS: 2713 (Part-I) 1980.

- 7.6** Purchaser reserves the right to inspect during manufacturing and depute his representative to inspect/test at the works.

- 7.7** If any extra cost is required for carrying out the above specified tests, the same shall be borne by the manufacturer.

**8 Marking:**

- 8.1** The poles shall be marked with designation, manufacturer's identification, year of manufacture and name of the purchaser: Employer Name; DDUGJY

- 8.2** The poles may also be marked with the ISI certification mark.

**9** Guaranteed technical particulars:

- 9.1** The manufacturer shall furnish all necessary guaranteed technical particulars in the prescribed Performa enclosed hereinafter.

**10 Performance:-**

- 10.1** The manufacturer shall furnish a list of the major supplies effected during the last 3 (three) years indicating the volume of supply and actual delivery dates.

**10.2** Manufacturer may not be considered if the past manufacturing experience is found to be less than 3 (three) years.

**11 Deviation:-**

Any deviation in technical specification shall be clearly indicated with sufficient reasons thereof. Purchaser shall however reserve the right to accept and/or reject the same without assigning any reasons whatsoever.

**ANNEXURE –‘A’**

**SPECIFIC TECHNICAL REQUIREMENTS FOR  
TUBULAR STEEL POLES : SWAGED TYPE**

	<b>9 meters long</b>	<b>11 meters long</b>	<b>13 meters long</b>	<b>12 meters long</b>
1) Standard	IS: 2713 ( Pat-I and III): 1980 as amended upto date			
2) Type of Pole	Swaged Type			
3) Designation	540 SP 28	540 SP 52	540 SP 72	410 SP 60
4) Overall Length	9 meters	11 meters	13 meters	12 meters
5) Planting depth	1.5 meters	1.8 meters	2.0 meters	2.0 meters
6) Height above ground	7.5 meters	9.2 meters	11.0 meters	10.0 meters
7) Effective length of Each section.				
a) Bottom	5.0 meters	5.6 meters	5.80 meters	5.80 meters
b) Middle	2.0 meters	2.7 meters	3.60 meters	3.10 meters
c) Top	2.0 meters	2.7 meters	3.60 meters	3.10 meters
8) Outside diameter and Thickness of each Section.				
a) Bottom	139.7x 4.50 mm	165.1x4.50 mm	219.1x5.90 mm	165.1x5.40mm
b) Middle	114.3x3.65 mm	139.7x4.50 mm	193.7x4.85 mm	139.7x4.50 mm
c) Top	88.9x3.25 mm	114.3x3.65 mm	165.1x4.50 mm	114.3x3.65 mm
9) Joint Length ( in cm.):				
a) Bottom (J2)	30 cm.	35 cm.	45 cm.	35 cm.
b) Top (J1)	23 cm.	30 cm.	40 cm.	30 cm.
10) Approximate weight of Pole	113 Kg.	175 Kg.	343 Kg.	208 Kg.
11)Point of application of load below/top (mtr.)	0.3 mtr.	0.6 mtr.	0.6 mtr	0.6 mtr
12) Breaking load ( inKgf )	478	567	1084	469
13) Working load with factor of Safety : 2.5 ( in Kgf )	191	227	435	188
14) Crippling load ( inKgf )	339	403	770	333
15) Load for permanent set Not exceeding 13mm (in Kgf)	232	276	527	228
16) Load for Temporary Deflection of 157.5 mm (in Kgf)	76	74	121	61
17) Tolerance	As per IS : 2713 ( Part-I & Part-III): 1980			
18) Finish	-do-			
19) Manufacturing clause	-do-			

**3. Hot Rolled Steel Beams (Joists)**

**1. SCOPE :-**

Specification covers the manufacture, testing at works and supply of various sizes of Hot rolled steel beams.

**2. APPLICABLE STANDARDS:**

The Mild shall be conforming to IS:2062 – 1992 GRADE ` A ` modified upto date or its equivalent international standard for steel materials, document for which shall be made available at the time of inspection to the Employer's representative. The dimensions of Hot Rolled Steel Beams shall be conforming to IS: 808 / 1989 amended upto date and tolerance as per IS : 1852 modified upto date.

**3. GENERAL REQUIREMENTS :**

Material shall be supplied as per the sizes and technical details as per following requirements and drawing.

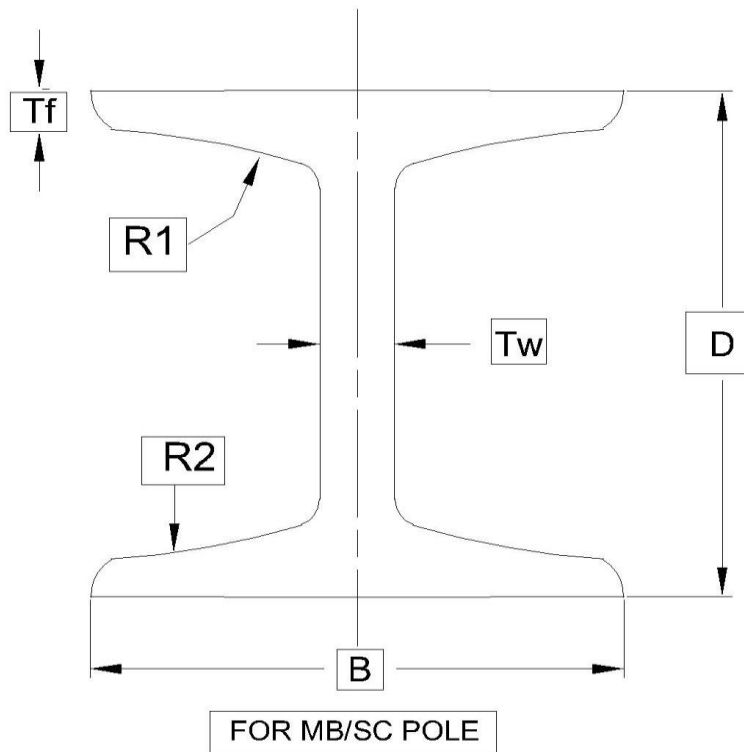

Note: 1) All Dimensions are as per annexure-I  
 2) Drawing is not to the scale

**ANNEXURE-I**

Sr.No.	Particulars	Requirement as per Specification	
		MB	SC
1	Designation (DxB) ( mm x mm )	175X85	152X152
2	Length of joist-Meter with +100 mm tolerance	9m	11m / 13m
3	Weight (kg/M)	19.6	37.1
4	Sectional area (A) (Sq.cm. )	25.0	47.4
5	Depth of section ( D ) (mm)	175	152
6	Width of flance ( B ) (mm)	85	152
7	Thickness of flance (Tf) (mm)	9	11.9
8	Thickness of Web (Tw) (mm)	5.8	7.9
9	Radius of fillet or root (R1) (mm)	10	11.7
10	Radius of tow (R2) (mm)	5	3
11	Moment of Inertia		
	(i) I xx ( cm <sup>4</sup> )	1260	1970
	(ii) I yy ( cm <sup>4</sup> )	76.7	700
12	Radius of Gyration GR xx (cm)	7.13	6.45
13	Modulus of Section		
	(i)Z xx (cm <sup>3</sup> )	144	259
	(ii)Z yy(cm <sup>3</sup> )	18	91.9
14	Tolerance in dimensions plus/minus	-----As per IS: 1852-----	

**4. Mild Steel Channel, Angle And Flat**

**1) APPLICABLE STANDARDS:**

The mild steel shall conform to IS: 2062 grade 'a' modified upto date or equivalent international standard for steel materials, documents for which shall be made available at the time of inspection to the owner's representative.

**2) GENERAL REQUIREMENTS:**

Material shall be supplied as per the following sizes:

100x50 ISMC channel conforming to IS: 2062 grade 'a' modified upto date or its equivalent International Standard having length ranging from 5.5 to 13.5 meters. 75x40 ISMC channel conforming to IS: 2062 grade 'a' modified upto date or its equivalent International Standard having length ranging from 5.5 to 13.5 meters.

50x50x8 mm or 6 mm ISA angles conforming to IS: 2062 grade 'a' modified upto date or its equivalent international standard having length ranging from 5.5 to 13.5 meters.

45x45x5 mm ISA angles conforming to IS: 2062 grade 'a' modified upto date or its equivalent international standard having length ranging from 5.5 to 13.5 meters.

60x65x6 mm ISA angles conforming to IS: 2062 grade 'a' modified upto date or its equivalent international standard having length ranging from 5.5 to 13.5 meters.

25X3mm, 50X6mm, 50x8mm, 75X8mm and 80X8 flats conforming to IS: 2062 grade 'a' modified upto date or its equivalent international standard having length ranging from 5.5 to 9.5 meters.

**3) GALVANISATION:**

All above steel members shall be fabricated as per approved drawing having smooth edge, drilled circular/elliptical holes of suitable measurements.

All structural steel members and bolts shall be galvanized as per IS:4759 and zinc coating shall not be less than 610gm/sq. meter for all structural steel members. All weld shall be 6mm filled weld unless specified otherwise. All nuts and bolt shall be of property class 5.6 of IS 1367. Plain washers shall be as per IS 2016 and spring washers shall be IS:3063

**4) INSPECTION:**

All inspection/test will be carried out by representative of owner.

All tests and inspection shall be made at the place of manufacturer unless otherwise specially agreed upon by the manufacturer and the owner. The manufacturer shall provide all reasonable facilities, without charge to satisfy him that the material is being supplied in accordance with the specification.

**5. 11 & 33 KV Outdoor Type Current Transformer**

**4.1 INTRODUCTION**

This section covers the specification of 33 kV and 11kV Current Transformer suitable for outdoor service. Any other parts not specifically mentioned in this specification but otherwise required for proper functioning of the equipment should be included by the tender in the offer. The CTs should normally be installed above VCB. The VCB & CT should be installed on common mounting structure. In places, where VCB are not provided in the Substation separate CT mounting structure shall be provided with CTs.

**4.2 APPLICABLE STANDARDS**

Unless otherwise modified in this specification, the Current Transformer shall comply with the latest version of relevant standards (IS 2165, IS 2705(I-IV), IS 2099, IS 5621, IS 2071, IS 335, IS 13947(part I), IEC 185, IEC 270, IEC 44(4), IEC 171, IEC 60, IEC 8263, IEC 815, Indian electricity Rules 2003) or better international standards. This list of standards is for guidance only. The contractor shall be solely responsible to design & manufacture the CT suitable for 33kV & /11 kV systems.

**4.3 AMBIENT CONDITIONS**

The CT supplied against these specifications shall be suitable for satisfactory continuous operation under the tropical conditions. The detail condition is mentioned in General Technical requirement.

**4.4 SYSTEM PARTICULARS**

a)	Nominal System Voltage	33kV & 11kV
b)	Highest system Voltage	36kV & 12kV
c)	Rated Frequency	50Hz & 50Hz
d)	No of phases	Three & Three
e)	System neutral earthing	-Solidly Earthed-
f)	One minute Power Freq. withstand voltage (rms)	70kV & 28kV
g)	Lighting Impulse withstand Voltage	170kVp & 75kVp
i)	System fault level	-25kA for 3sec-

**4.5 TECHNICAL PARAMETERS OF CT**

a)	Type	Single phase, dead tank, outdoor,oil filled & hermetically sealed
----	------	---

b)	Type of mounting	Pedestal type	
c)	Rated primary current	As per BPS	
d)	Rated Continuous thermal current Primary current	120 % of rated	
e)	Rated short time withstand Requirement for sec. Winding	As per IS 2705 Pt. I	
f)	Rated short time withstand Current	25kA(RMS)	
	i) Duration (for primary current of 150amps and above)	3Sec	
	ii) Duration (for primary current below 150amps)	1Sec	
g)	Rated dynamic withstand Current (KA rms)	62.5	
h)	Max temp rise	As per IEC-185/ IS 2705	
i)	Minimum creepage distance of porcelain housing(mm)	25 mm /KV	
j)	One minute power frequency Withstand voltage between Secondary terminal & earth	3 kV	
k)	Detail of Secondary Cores	Metering	Protn.
	Current ratio	(As per BPS)	
	Accuracy class	0.5	5P10
	Burden (VA)	30	30
	Instrument security Factor	≤5	-
	Accuracy Limit Factor	-	≥10

**Note:** The ratings indicated for instrument transformer are tentative only and may be changed to meet the requirements.

#### 4.6 PORCELAIN HOUSING



It shall be single piece of homogeneous, vitreous porcelain of high mechanical & dielectric strength. It will be glazed with uniform Brown or Dark brown colour with smooth surface finish. The creepage distance for the porcelain housing shall be at least 25 mm per kV.

#### **4.7 WINDING**

##### **1 PRIMARY WINDING**

It shall be made of high conductivity rigid copper wire. The primary winding current density shall not exceed the limit of 1.6 Amp per sq. mm for normal rating.

The design current density for short circuit current as well as conductivity of metal used for primary winding shall be as per IS 2705. The calculation for the selection of winding cross section shall be furnished by contractor.

The primary terminal shall be of standard size of 30 mm dia x 80 mm length of heavily tinned (min. thickness 15 micron) electrolytic copper of 99.9 % conductivity.

##### **2 SECONDARY WINDING**

shall be made of insulated copper wire of electrolytic grade. Type of insulation used shall be described in the offer. For multi ratio design, the multi ratio will be achieved by reconnection of the primary winding or secondary winding. The excitation current of the CT shall be as low as possible. The contractor shall furnish the magnetization curves for all the cores.

The terminal box shall be dust free & vermin proof. The size of the terminal box shall be big enough to enable easy access and working space with the use of normal tools.

The secondary terminals studs shall be provided with at least 3 nuts and two plain washers, these shall be made of brass duly nickel plated. The min. stud outer dia shall be 6 mm & length 15 mm. The min spacing between the centres of the adjacent studs shall be 1.5 time the outer dia of the stud.

##### **3 POLARITY**

The polarity shall be marked on each CT at the primary and secondary terminals.

#### **4.8 TANK & HARDWARES**

The CT will be dead tank type. The tank shall be fabricated of MS steel sheet of min. 3.15 mm for sides & 5 mm for top & bottom. The tank will be finished with min. 2 coats of zinc rich epoxy paint externally. The inner surface shall be painted with oil resistance white enamel paint.

All ferrous hardwares, exposed to atmosphere shall be hot dipped galvanized.

#### **4.9 INSULATION OIL**

The first filling of oil in CT shall be in contractor's scope. The oil shall be as per IS 335.

**To ensure prevention of oil leakage, the manufacturer will give following details supported by drawings:**

- i) Location of emergence of Primary & Secondary terminals
- ii) Interface between porcelain & metal tanks
- iii) Cover of the secondary terminal box

Any nut & bolt and screw used for fixation of the interfacing porcelain bushing for taking out the terminals shall be provided on flanges cemented to the bushings & not on the porcelain.

If gasket joints are used, Nitrite Butyl Rubber gasket shall be used. The grooves shall be machined with adequate space for accommodating gasket under pressure.

The CT shall be vacuum filled with oil after processing. It will be properly sealed to eliminate breathing & to prevent air & moisture from entering the tank. The sealing methods/arrangement shall be described by the contractor & be approved by the owner.

#### **4.10 OIL LEVEL INDICATOR**

The CT shall be fitted with prismatic type oil sight window at suitable location so that the oil level is clearly visible with naked eye to an observer standing at ground level.

To compensate oil volume variation due to temperature variation, Nitrogen cushion or the stainless steel bellows shall be used. Rubber diaphragms are not permitted for this purpose.

#### **4.11 EARTHING**

Two earthing terminals shall be provided on the metallic tank of size 16 mm dia & 30 mm length each with one plain washer & one nut for connection to the station earth mat

#### **4.12 Junction Box**

The junction box shall be of MS sheet having thickness of 2mm, synthetic enamel painted as per procedure mentioned in General Technical Requirement (Min. thickness 55 micron). The shade of junction box shall be 697 of IS: 5. Disconnecting type terminal blocks for CT secondary lead shall be provided. The junction boxes shall be weather proof type with gaskets, as per section-I (Introduction and general technical requirements) conforming to IP-55 as per IS-13947 (Part-I).

#### **4.13 LIFTING & MOUNTING ARRANGEMENT**

The CT shall be provided with two lifting eyes to lift the CT. This shall be so positioned so as to avoid any damage to the CT during lifting for instillation or transportation purpose. This shall be detailed in General Arrangement drawing.

The CT shall be of pedestal mounting type suitable for outdoor installation on steel/cement concrete structures. All the clamps, bolts, nut and washers etc. required for mounting the CT on the structure shall be supplied along with the CT and shall be galvanized. The contractor shall supply all the terminal connectors etc. required for connection to the CT.

#### **4.14 TESTING**

All Type and Routine Tests shall be as per relevant IS and/or IEC.

**6. 33 & 11 kV Outdoor Type Potential Transformer**

**1 INTRODUCTION**

This chapter covers specification of 33kV and 11kV Potential Transformer suitable for outdoor service. Any other parts not specifically mentioned in this specification but otherwise required for proper functioning of the equipment should be included by the tender in the offer.

**2 APPLICABLE STANDARDS**

Unless otherwise modified in this specification, the Potential Transformer shall comply with the latest version of relevant standards (IS 3156, IS 2099, IS 5621, IS 335, IS 13947(Part I), IEC 186, Indian electricity Rules 2003, IEC 815) or better international standards. This list of standards is for guidance only. The contractor shall be solely responsible to design & manufacture the PT suitable for 33 kV/11kV systems.

**3 AMBIENT CONDITIONS**

The PT supplied against this specification shall be suitable for satisfactory continuous operation under the tropical conditions as detailed in general technical requirement.

**4 SYSTEM PARTICULARS**

a)	Nominal System Voltage	33kV	11kV
b)	Highest system Voltage	36kV	12kV
c)	Rated Frequency	50Hz	50Hz
d)	No of phases	Three	Three
e)	System neutral earthing	---Solidly Earthed---	
f)	One minute Power Freq. Withstand voltage (rms)	70kV	28kV
g)	Lighting Impulse withstand Voltage	170kVp	75kVp
h)	System fault level	---25 kA for 3sec---	

**5 TECHNICAL PARAMETERS OF PT**

a)	Rated primary Voltage	36 KV	12 KV
b)	Type	Single phase potential transformer	
c)	Voltage/ Ratio(kV)	33/0.11	11/0.11
d)	Rated voltage factor	1.2continuous	1.5 – 30seconds-
e)	One minute power freq. Withstand voltage for Primary Terminals	70 kV(rms)	28 kV

	Secondary winding	36 kV	12 KV
f) Min. Creepage Distance		25 mm/kV of Highest System Voltage	
g) Detail of secondaries	Core I	Application Metering	
	Accuracy	0.5	0.5
	Burdan (VA)	100	100

**Note:** The ratings indicated for instrument transformer are tentative only and may be changed to meet the requirements.

## 6 PORCELAIN HOUSING

It shall be single piece of homogeneous, vitreous porcelain of high mechanical & dielectric strength. It will be glazed with uniform Brown or Dark brown colour with smooth surface finish. The creepage distance for the porcelain housing shall be at least 25mm per kV.

The contractor shall clearly detail in his bid the details of attaching the metallic flange to porcelain, pressure release valve and also how primary & secondary terminals shall be brought out.

## 7 WINDING

### PRIMARY WINDING

It shall be made of insulated electrolytic copper wire. The neutral end of the winding shall be brought outside for earthing.

The primary terminal shall be of standard size of 30 mm dia x 80 mm length of heavily tinned (min. thickness 15 micron) electrolytic copper of 99.9 % conductivity.

### SECONDARY WINDING

It shall be made of insulated copper wire of electrolytic grade. The terminal box shall be dust free & vermin proof. The size of the terminal box shall be big enough to enable easy access and working space with the use of normal tools.

The secondary terminals studs shall be provided with at least 3 nuts and two plain washers. These shall be made of brass duly nickel plated. The min. stud outer dia shall be 10 mm & length 15 mm. The min spacing between the centres of the adjacent studs shall be 1.5 time the outer dia of the stud.

### POLARITY

The polarity shall be marked on each PT at the primary and secondary terminals.

## 8 TANK & HARDWARES

It shall be fabricated of MS steel sheet of min. 3.15 mm for sides & 5 mm for top & bottom. The tank will be finished with min. 2 coats of zinc rich epoxy paint externally. The inner surface shall be painted with oil resistance white enamel paint.

All ferrous hardware, exposed to atmosphere shall be hot dipped galvanized.

## **9 INSULATION OIL**

The first filling of oil in PT shall be in contractor's scope. The oil shall be as per IS 335. To ensure prevention of oil leakage, the manufacturer will give following details supported by drawings:

- i) Location of emergence of Primary & Secondary terminals
- ii) Interface between porcelain & metal tanks
- iii) Cover of the secondary terminal box

Any nut & bolt and screw used for fixation of the interfacing porcelain bushing for taking out the terminals shall be provided on flanges cemented to the bushings & not on the porcelain.

If gasket joints are used, Nitrite Butyl Rubber gasket shall be used. The grooves shall be in machined with adequate space for accommodating gasket under pressure.

The PT shall be vacuum filled with oil after processing. It will be properly sealed to eliminate breathing & to prevent air & moisture from entering the tank. The sealing methods/arrangement shall be described by the contractor & be approved by the owner.

## **10 OIL LEVEL INDICATOR**

The PT shall be fitted with prismatic type oil sight window at suitable location so that the oil level is clearly visible with naked eye to an observer standing at ground level.

To compensate oil volume variation due to temperature variation, Nitrogen cushion or the stainless steel bellows shall be used. Rubber diaphragms are not permitted for this purpose.

## **11 EARTHING**

Two earthing terminals shall be provided on the metallic tank of size 16 mm dia & 30 mm length each with one plain washer & one nut for connection to the station earth mat

## **12 Junction Box**

The junction box shall be of MS sheet having thickness of 2mm, synthetic enamel painted as per procedure mentioned in General technical Requirement (Min. thickness 55 micron). The shade of junction box shall be 697 of IS: 5. Disconnecting type terminal blocks for PT secondary lead shall be provided. The junction boxes shall be weather proof type with gaskets as per section-I (Introduction and general technical requirements) conforming to IP-55 as per IS-13947 (Part-I).

One junction box shall be provided for 3 numbers of single phase CT's and PT's.

## **13 LIFTING & MOUNTING ARRANGEMENT**

The PT shall be provided with two lifting eyes to lift the PT. This shall be so positioned so as to avoid any damage to the PT during lifting for installation or transportation purpose. This shall be detailed in General Arrangement drawing.

The PT shall be of pedestal mounting type suitable for outdoor installation on steel/cement concrete structures. All the clamps, bolts, nut and washers etc. required for mounting the PT on the structure shall be supplied along with the PT and shall be galvanized. The contractor shall supply all the terminal connectors etc. required for connection to the PT.

**14 TESTING**

All Type and Routine Tests shall be as per relevant IS and /or IEC.

**7. 11 kV AND 33 kV Vacuum Circuit Breakers**

**1) SCOPE**

This specification covers design, manufacturing, testing at manufactures works, supply of 11KV and 33 KV Vacuum Circuit Breakers complete with all accessories required for their satisfactory operation for the sub-transmission system. The Breakers shall be used for Transformer protection or Feeder Control, in the system.

**2) TYPE AND RATING**

The circuit breakers shall be suitable for outdoor operation under the climatic conditions, as specified in Tender specification, without any protection from sun and rain.

The circuit breakers shall have the following rating:-

S.No.	PARTICULARS	33 KV 11 KV	
i)	Number of Poles	3 Nos.	
ii)	Frequency	50 Cycles	
iii)	Nominal System Voltage	33 KV	11 KV
iv)	Highest System Voltage	36 KV	12 KV
v)	Interrupting Capacity at nominal system voltage	1500 MVA	1500 MVA
vi)	Rated Continuous Current	1250 Amps	1250 Amps
vii)	Short-time Current Rating for 3 Secs.	25 KA	25 KA
viii)	Basic Insulation Level	170 KV	75 KV
ix)	Power Frequency Withstand Voltage for one Minute	70 KV	28 KV
x)	Total Break-time for any Current up to the rated breaking current	5 cycles (max.)	
xi)	Control Circuit Voltage	30 Volt D.C.	
xii)	Operating duty for gang operation	O – 0.3 Sec – CO – 3 Min – CO	
xiii)	The VCBs shall be suitable for one reclosing followed by one delayed reclosing and lock out		
Minimum clearances			
a)	Between Phases	430 mm	280 mm
b)	Between Live Parts & Ground	3700 mm	2750 mm
c)	Creepage Distance	900 mm	300 mm

The above are our minimum requirements. The *manufacturers* may offer their standard design, keeping in view our minimum requirements.

### 3) STANDARDS

The circuit breakers shall comply with the requirements of IEC 56 or IS 13118 (1991) with latest amendment thereof, except wherein specified otherwise. Equipment, meeting any other authoritative standard, which ensures equal or better quality than the standard mentioned above, would also be acceptable. The bidders shall clearly indicate the applicable standards to which their equipments complies-with. A copy of such standard may also be enclosed.

### 4) GENERAL

The circuit breaker shall be of porcelain clad vacuum type. The breaker, complete in all respect, shall be supplied with all accessories in-place and all internal wiring installed and terminated in the mechanism housing and the equipment shall be complete in all respects.

The circuit breakers shall provide rapid and smooth interruption of current under all conditions, completely suppressing all undesirable phenomena, even under the most severe and persistent short-circuit conditions or when interrupting small currents or leading/ lagging reactive currents. The details of any device incorporated to limit or control the rate of rise of Restriking voltage across the circuit breaker contacts shall be stated. The over voltage caused by the circuit breaker switching on inductive or capacitive load shall not exceed 3.2 times the normal phase to neutral voltage. The total break-time for the circuit breaker, throughout the range of breaker operating duty, shall be stated in the tender and shall be guaranteed. The breaker shall be fit for capacitor switching for 5 MVar Bank.

The breakers shall be provided with trip free mechanism.

The circuit breakers shall be suitable for mounting on steel structures. The cost of necessary frames for mounting the circuit breakers shall be included in the offered prices. Strongly supported bracket or frame, for mounting associated 3 nos.11 KV / 33 KV CTs, shall also be provided. All the structures shall be hot dip galvanized with 3 dips. Please note that cantilever type supports for mechanism box are not acceptable. The mechanism box shall have firm supports from bottom. This is necessary to minimize vibration of mechanism box, which in turn may disturb various settings. The agency shall indicate clearly the vibration level of the breaker during fault / normal ON OFF operations in all three directions.

The owner intends to operate 11 KV and 33 KV feeders with automatic reclosing scheme, the arrangement envisaged is as under:-

On the occurrence of a fault the concerned protective relay will open the circuit breaker as per its own characteristic. Thereafter, the breakers shall re-close but after pre-set time delay, which shall be adjustable (say range 4 – 10 sec. or near about). There shall be no further automatic reclosing. A simple type of reclosing relay (reputed make) for this purpose shall be provided under this kind of operation. It is also necessary that the breaker shall be suitable for this reclosing duty. The auto-recloser relay is to be installed in respective indoor control panels.

### 5) SPECIFICATION FOR CIRCUIT BREAKERS

The circuit breakers shall consist of three identical phase units with a common operating mechanism. While offering the circuit breaker, the following details should be confirmed and furnished with the tender:-



- i) Complete construction details of the equipment offered. It should be noted that the breakers should be suitable for out-door duty. Indoor breakers accommodated in out-door kiosks are not acceptable.
- ii) Type, make & source of vacuum bottles with relevant details shall be indicated in the offer, clearly.
- iii) The capacity of breaker to interrupt inductive and capacitive currents shall be indicated in the offer (rating of capacitor bank should be stated and type test report shall be furnished).
- iv) Spare availability of vacuum interrupter should be confirmed by the bidder for the designed expected life of the breakers being offered.

## **6) VACUUM INTERRUPTER**

The design of the vacuum interrupter shall be such that it gives trouble free operation under normal load and fault conditions throughout the life of the equipment. As the efficiency of the breaker depends on the degree of vacuum inside the interrupter, manufacturer shall ensure that the same is maintained consistently during service. To know the residual life of vacuum interrupter, an indicator to indicate the status of contact erosion shall be provided.

The insulating ceramic body of the interrupter should have high mechanical strength and it should be capable of withstanding high temperature without any significant deterioration in its mechanical and electrical properties

The metal/ alloy used for the fixed and moving contacts shall have very low resistivity and low gas content. They should be resistant to arc erosion and the contact should have no tendency to get cold-welded under the high vacuum in the interrupter.

The interrupter design should ensure rapid de-ionization of the gap so that normal electrical strength of the gap is restored instantaneously.

The metallic bellow or any other similar vacuum sealing arrangement should be provided at the moving contact and should have a long fatigue life.

Manufacturer's catalogue on vacuum bottle, indicating all the details shall essentially be submitted with the tender.

## **7) MOUNTING OF 11 KV / 33 KV CTs**

The offered steel structures for breakers to be supplied by the bidders should have provision and adequate strength to accommodate 3 nos. 11 KV / 33 KV CTs on it after provision of suitable supports from ground.

## **8) TEMPERATURE RISE**

The maximum temperature attained by any part of the equipment, when in service at site, under continuous full load conditions, exposed to the direct rays of the sun, shall not exceed 45° Centigrade, above ambient temperature. The limits of temperature rise shall be as per relevant standards. The corrections proposed shall be stated in the tender and shall be subject to approval of the owner.

## **9) INSULATION OF THE CIRCUIT BREAKER**

The insulation to ground, the insulation between open contacts and the insulation between phases of the completely assembled circuit breaker shall be capable of withstanding satisfactorily di-electric test voltage corresponding to specified basic insulation level in the standard.

**10) INSULATORS**

The basic insulation level of the Insulator and insulating porcelains shall be as specified and porcelain shall be homogenous and free from cavities and other flaws. They shall be designed to have ample insulation, mechanical strength and rigidity for satisfactory operation under conditions specified above. All insulators of identical ratings shall be inter-changeable. The puncture strength of the insulators shall be greater than the flash over value. The insulators shall be type tested from independent Govt. Laboratory as per relevant standards or at any recognized and reputed international laboratory or testing institutions.

**11) OPERATING MECHANISM**

The circuit breakers shall be designed for remote control from the control room and in addition there shall be provision for manual operation of circuit breakers during maintenance and for local tripping and closing by the normal means.

The circuit breakers shall have operation control and mechanical "open" "close" indicator, in addition to facilities for remote electrical indication.

The operating mechanism shall be of the spring charging type, by electric control under normal operation. The mechanism shall be trip free electrically and mechanically. The mechanism shall be capable of performing satisfactorily, the reclosing duty cycles indicated above, within the time specified. All working parts in the mechanism shall be of corrosion resistant material and all bearings, which require greasing, shall be equipped with pressured grease fittings. The mechanism shall be strong positive quick in action and shall be removable without disturbing the other parts of the circuit breaker. The mechanism and breaker shall be such that the failure of any spring will not prevent tripping and at the same time will not cause any false tripping or closing. The operating Mechanism should be motor operated spring charged type preferably without chain drive. The motor for spring charging shall be suitable to perform satisfactorily for input supply voltage of 230 Volt A.C. 50 Hz with a variation of plus 10 and minus 20 percent. The A.C. Motor should have overload protection. Provision should also be made for mounting of mechanism box at an adequate height and gear ratios shall be so chosen that one man should be able to charge the spring, without any additional efforts.

**12) CONTROL CUBICLE**

A common control cubicle shall be provided to house electrical, controls, monitoring devices and all other accessories, except those which must be located on individual poles. The cubicle shall be gasketed and shall have weather-proof construction, fabricated from sheet steel of minimum 2.5 mm thickness. The type test report on degree of protection test (IP-55) shall also be furnished.

The cubicle shall have front access door with lock and keys, space heater, internal illumination lamp, 3 pins 5 Amp socket with individual ON-OFF switches shall be provided in the cubicle.

For local operation following shall be provided:-

- a) LOCAL / REMOTE selector switch

- b) TRIP / NORMAL / CLOSE control switches with pistol grip handle

The control circuits shall be designed to operate on 30 Volt DC, as indicated in the schedule and it shall be possible to adopt to work on other voltages by simply changing the operating coils. The shunt tripping coils shall be designed to operate satisfactorily within 110% and 70% of the rated DC supply voltage and the shunt closing coils should operate up to 85% of the rated DC voltage. These checks shall be repeated during pre-commissioning checks at site before putting the breakers in service.

AC Power supply for auxiliaries will be available at 230 Volt (+/- 10% variation) single phases 50 C/s at substation. The agency shall be required to extend this supply, using proper protection, to desired location through cable.

Necessary double compression type cable glands for the cables of the operating mechanism shall be provided. The cables used for operation are all un-armoured 2.5 sq. mm copper control cables of 1100 V grade. The cable glands shall be suitable for 1 no. 8 core and 2 nos. 4 core cables and cables as per site requirements. The gland plate should be made of non-magnetic materials and suitably drilled at site to suit the cable entry.

The Circuit breaker shall be provided with trip free Mechanism so that tripping instructions could over-ride the closing instructions. An additional tripping coil shall also be provided in the trip circuit. The second coil shall have separate tripping lever arrangements in the mechanism, so as to avail full advantage of second trip coil. Also the two trip coils shall have separate fuses in the DC circuit, so that in the event of any short circuit/damage in any one of the trip coils, the supply is available to the other one.

The circuit diagram of Control circuit of VCB along with operating instructions (DOS/ DON'T) shall be embossed on metallic plate duly laminated and the same shall be fixed on the rear door of the control cubicle from inside.

### **13) WIRING**

Wiring shall be completed in all respects to ensure proper functioning of the control, protection, monitoring and interlocking schemes.

All the wiring shall be carried out with 1100 V grade, PVC insulated stranded copper conductor of 2.5 sq. mm as per IS: 1554.

Each wire shall be identified at both ends with permanent markers bearing wire numbers as per wiring diagram.

Wire termination shall be done with crimping type connectors with insulating sleeves. Wires shall not be spliced between terminals.

All spare contacts of auxiliary switches etc. shall be wired up to terminal blocks in the control cubicle.

### **14) TERMINAL BLOCKS**

Terminal blocks shall be of 1100 V grade, box clamp type ELMEX 10 sq. mm or approved equivalent. Not more than two wires shall be connected to any terminal. Spare terminals, equal in number to 20% of active terminals, shall be provided.

Terminal block shall be such located to allow easy access. Wiring shall be so arranged that individual wires of an external cable can be connected to consecutive terminals.

**15) TERMINAL CONNECTORS**

6 Nos. Terminal bi-metallic connector suitable for Dog conductors shall be supplied with each breaker. For ensuring quality and uniformity, the owner may decide to specify the design of terminal connector, the material of terminal connector and thickness of clamps. Further compliance of which will have to be done by the agency without any extra cost. Suitable earth connector for earthing connections shall also be supplied. The connector drawing shall be got approved from the owner.

**16) AUXILIARY CONTACTS**

Eight numbers each of auxiliary contacts both of the normally open and normally closed types shall be provided in each circuit breaker for use in the remote indication and control scheme of the circuit breaker and for providing safety interlocking. Special contacts for use with trip coils, which permit for relative adjustment with respect to the travel of the circuit breaker contact, shall also be provided, wherever required. There shall be provision to add more auxiliary contacts at a later date, if required.

**17) ACCESSORIES**

The vacuum circuit breaker shall be supplied as a complete unit with internal wiring installed and terminated in mechanism box and equipped with the following accessories:

1	Motor operated spring charged mechanism (Motor voltage – 230 V AC)	1 No.
2	Trip coil suitable for 30 V DC	2 Nos.
3	Closing Coil suitable for 30 V DC	1 No.
4	Pistol grip C.B. Control switch having Trip/ Normal/ Close position	1 No.
5	Local/ Remote selector switch	1 No.
6	Spring Charged indicator	1 No.
7	Manual operating handle for maintenance	1 No.
8	Facility for manual charging of spring	1 No.
9	Operation counter	1 No.
10	Auxiliary contacts (8 NO-8 NC)	1 Set
11	Anti-pumping device suitable for 30 V DC	1 No.
12	Terminal connectors suitable for connecting Dog Conductor	6 Nos.
13	Cubicle illuminating lamp with cage and switch	1 No.
14	Spare terminals connectors	20% of Total Terminals

15	Mechanical ON/OFF Indicator	1 No.
16	MCB for both AC and DC supply	1 No. each
17	Space heater and ON-OFF switch in the mechanism box	1 No.
18	Power Type 3 Pin Socket with ON-OFF switch	1 Set
19	Earthing Terminals	2 Nos.
20	LED indicating lamps	Complete set

**Indicating Bulbs:**The indicating lamps should be supplied with Low Voltage protection Circuit (LVGP) and surge suppressor circuit having LED indication. Lamp assembly should be of fire – retardant glass epoxy PCB, industrial heat resistant, fire resistant, non- Hygroscopic DMC material , chrome – plated corrosion resistant solid brass bezel , polycarbonate lens in desired colour shades of Red , Green, Amber, Yellow etc. the intensity of light should be minimum 100 mcd at 20 mA . Indication lamp should be suitable to operate on 30 V Direct Current supply source.

**18) TYPE TESTS**

Type test certificates on VCB for the following tests, strictly as per IS 13118, with latest amendment thereof, from any of the independent Govt. Laboratory, or at any recognized and reputed international laboratory or testing institution, shall invariably furnished :-

- Short Circuit Duty Tests
- Short Time Current Rating Tests
- Mechanical Endurance Test
- Temperature Rise Test
- Lightning Impulse Voltage withstand Test
- Capacitor Switching Duty Test for Single Bank of 5 MVAR capacity
- Power Frequency withstand Voltage Test dry & wet
- Degree of protection IP-55 for control cubicle

The above type test certificates must accompany drawing of type tested equipment, duly signed by type testing authority.

The above tests must not have been conducted on the equipment earlier than 5 years from the date of opening of bids.

In case of any change in design/type of Breaker already type tested and the one offered against this specification, the owner reserves the right to demand repetition of type tests, without any extra cost.

**19) ACCEPTANCE AND ROUTINE TESTS**

All acceptance and routine tests, as stipulated in relevant standards, shall be carried out by the manufacturer, in presence of owner’s representative

Immediately after finalization of the programme of type testing, the manufacturers shall give, fifteen days advance intimation to the owner, to enable him depute his representative for witnessing the tests.

**20) RATING PLATES**

The detailed rating plate shall be as per IS and in addition, shall indicate serial number of the equipment, manufacturer's name, our order number and date.

**21) EXPERIENCE**

Minimum 3 years' experience in the field of design and manufacture of the equipment offered is essential for the bidder. Details in this regards shall be clearly stipulated in the offer.

**8. 11 kV 350MVA 1250 AMP VCB Switchgear Panels (MC VCB) - Indoor**

**1.1. INTRODUCTION**

- 1.1.1. The section covers the specification of metal clad indoor vacuum type switchgear unit with horizontal draw out circuit breaker as per IS 13118 [1991] / IEC 62271-100 or latest amendment thereof.
- 1.1.2. All the equipments shall be suitable for satisfactory operation in tropical climates and dry dust laden atmosphere prevailing in the location where it shall be used against the Contract. The equipment shall be able to with stand a wide range of temperature variation in the required location
- 1.1.3. All the plant/apparatus/equipment supplied shall comply in all respect with the requirement of Indian Electricity Act 2003 and Indian Electricity Rule 2003/IS and latest amendment thereof during the execution of contract where-ever applicable

**1.2. STANDARDS.**

The circuit Breaker shall confirm to the latest revision with amendment available of relevant standards, rules, and code. Some of which are listed herein for ready reference.

Sl. No.	Standard	Item
1.	IEC- 62271-100 /IS- 13118(1991)	Switchgear
2.	IS-2705 (1992)	Current Transformer
3.	IS-3156 (1992)	Voltage Transformer
4.	IS-3231 (1987)	Relays
5.	IS-1248	Ammeter & Voltmeter
6.	IS-375	Arrangement of Breakers Bus Bars main connection and auxiliary wiring.
7.	IEC-60687/CBIP REPORT NO-88 (JULY) 1996)	Tri vector meter

**1.3. CONSTRUCTION**

- 1.3.1. The switchgear shall be of CRCA steel construction with sheet not less than 3mm thickness for load bearing section and not less than 2 mm thickness for non-load bearing and shall totally dust and vermin proof. However, if vendor has standardized the thickness of enclosure other than above mentioned and it meets the performance requirements and the design has been established through type test, the same shall be accepted. The panels shall be rigid without using any external bracings. The switchboard panels should comply with relevant IS/IEC and revision thereof and shall be designed for easy operation maintenance and further extension. Bus bar, metering circuit breaker chamber, cables and cable box chamber should have proper access for maintenance, proper interlocks should be provided. All instruments shall be non-draw out type and safe guard in every respect from damages and provided with mechanical indicator of connection and disconnection position. The switchgear shall be completed with all necessary wiring fuses, auxiliary contacts terminal boards etc.

- 1.3.2. The arcing contacts and bus bar should be rated for 350 MVA for 3 seconds. Bus bars shall be capable of connecting one switchgear panel to other through proper insulated arrangement, which does not decrease the insulation strength of the bus bar at the point of connection between two panels. The panels shall be modular in design.
- 1.3.3. The breakers should be able to be drawn out in horizontal position at ground level [with vertical/horizontal isolation] when breaker is drawn out in horizontal position none of the live components inside the 11 KV switchgear panel should be accessible. The safety shutters shall be robust and shall automatically cover the live components when the breaker is drawn out. The switchgear shall have complete interlocking arrangements at the fully inserted and fully drawn out and test positions. Withdrawal of the breaker should not be possible in ON position, it should not be possible to close the circuit breaker in service unless the entire auxiliary and control circuit are connected.
- 1.3.4. Breaker should have three distinct positions inside the cubical; i.e. service, test and isolated.
- 1.3.5. Built-in/separate trolley mounted earthing switches for incomer and outgoing shall be provided.
- 1.3.6. All the high voltage compartments must have pressure discharge flap for the exit of gas due to internal arc to insure operator safety. All the HV compartment design ensures conformity to IEC-60298 and must be type tested for Internal Arc Test.

**1.4. BUS BARS AND CONNECTORS**

- 1.4.1. Bus bars and all other electrical connection between various components shall be made of electrolytic copper of rectangular cross sections. The bus bars section shall be ample capacity to carry the rated current of minimum 1250 Amp continuously without excessive heating and for adequately meeting the thermal and dynamic stresses in the case of short circuit in the system up to full MVA rating specified in Para 3.2 above.
- 1.4.2. All bus bars connections shall be firmly and rigidly mounted on suitable insulators to withstand short circuit stresses and vibrations.
- 1.4.3. Adequate clearance between 11 KV point and earth and between phase shall be provided to ensure safety as per provision in Indian Electricity Rule 2003 and its amendment thereof and also in accordance with the relevant Indian standard specification and the same shall be capable of withstanding the specified high voltage tests as per IS-13118/ IEC 62271-100 and amendment thereof.
- 1.4.4. Sharp edges and bends either in the bus bars or bus bar connections shall be avoided as far as possible. Wherever such bends or edges are un-avoidable, suitable compound or any other insulation shall be supplied to prevent local ionization and consequent flashover.

**1.5. CIRCUIT BREAKER**

- 1.5.1. The vacuum circuit breaker shall be draw out type suitable for installation in the switchgear cubicles (indoor). The breaker shall comply with IS-13118 (1991)/ IEC 62271-100 and latest amendment thereof. Construction of breaker shall be such that the points, which require frequent maintenance, shall be easily accessible.
- 1.5.2. The circuit breakers shall be spring operated, motor/manually charging of the spring feature, manually released. VCB shall have spring closing mechanism for 3 pole simultaneous operation. The speed of closing operation shall be independent of the speed of hand operating level. The indication device shall show the OPEN and CLOSE position of breaker visible from the front of cubical.
- 1.5.3. The breakers shall be capable of making and breaking the short time current in accordance with the requirement of IS 13118(1991)/ IEC 62271-100 and latest amendment thereof and shall have three phase rupturing capacity of 350MVA for 3 second at 11 KV. The continuous current rating of breaker shall not be less than 1250 Amp for all items. The total break/make time shall be not more than 4 cycles for break and 6 cycles for make time for all breakers.



- 1.5.4. The vacuum circuit breakers shall ensure high speed extinction and adequate control of pressure during breaking of current and also designed to limit excessive over voltages.
- 1.5.5. Comprehensive interlocking system to prevent any dangerous or inadvertent operation shall be provided. Isolation of circuit breaker from bus bar or insertion into bus bar shall only be possible when the breaker is in the open position.
- 1.5.6. Vacuum Circuit Breaker shall have completely sealed interrupting units for interruption of arc inside the vacuum. The vacuum bottle sealed for life shall be provided with contact wear indicator.
- 1.5.7. Vacuum interrupter should have an expected life of 10000 operations at rated current and should be capable for operating more than 100 times at rated short circuit current.
- 1.5.8. Vacuum interrupter technical data particularly provided by the manufacturer should also be provided with Bid.

**1.6. PROTECTION RELAYS**

- 1.6.1. All relays shall conform to the requirements of IS:3231/IEC-60255 or other applicable standards. Relays shall be suitable for flush or semi-flush mounting on the front with connections from the rear. The relay for entire project shall be of same type. The protective relay shall be numerical type. Composite relay unit having O/C, E/F & directional element etc shall be preferred.
- 1.6.2. The protective relays mounted on the panels shall be of the draw out type. The relays must be capable of resetting with out necessity of opening the case. The relays shall be provided with flag indicators. Each functional element of a relay shall be provided with its own flag indicator to enable the type of fault condition to the identified.
- 1.6.3. Each of the incomer/outgoing switchgear units shall be provided with 3 elements of 5 Amp Non-directional, over current relays and 1 element non-directional, earth fault relay with self/hand reset contacts. The O/C element shall have setting of 30 to 120% in seven steps and E/F element shall have setting of 10 to 40% in seven steps. However, final decision regarding selection of steps and setting of relay shall be decided during detail Engg. for proper co-ordination of protection system.
- 1.6.4. High set instantaneous element of low transient over reach not exceeding 5% should be incorporated in the O/C and Earth Fault relays for all the outgoing feeder panels capable of adjusting the setting from about 5 to 20 times normal rating in the O/C relays and 2 to 8 times in Earth Fault relays.
- 1.6.5. During detail engineering provision for shunt trip or series trip relays shall be decided by Employer for which contractor should not have any objection. Further, in this case, the series trip relays auxiliary unit contracts in the tripping circuit should be designed to handle current up to 150 Amp. and like wise trip coil voltage which appears across open contact of the series-tripping unit, be limited to 150 volts.
- 1.6.6. With CTs used as per Para 7.1 and taking into account the trip coil impedance of breaker with the plunger DOWN and with plunger UP position, the VA burden of relays offered etc. should be duly coordinated, so that the protection operates without errors at fault current corresponding to the fault MVA of 350 for all the tap position of the relays and the values of the impedance of the choke and resistance which may be required should also be determined and incorporated
- 1.6.7. The protective relays shall withstand 20 times the maximum current for 3 second on any tap setting. The over shoot time on removal of current setting shall not be greater than 0.05 seconds.

**1.7. CURRENT TRANSFORMERS:**

- 1.7.1. The requirement of ratio, VA capacity, class or accuracy, limit factor etc. for resin cast CTs installed in different type of units are tabulated below:

Item	Core/CT	Ratio	VA Burden	Knee Point	ALF	Class of accuracy

			(min)	Voltage		
Incoming Panel	Protection	600-300/1A	15	300 at 600/1A tap	10	PS
	Protection	600-300/5A	15	.....	10	5P
	Metering	600-300/5A	2.5	.....		0.5
Outgoing Panel	Protection	600-300/5A	15	.....	10	5P
	Metering	600-300/5A	2.5	.....		0.5

- 1.7.2. Short time rating of CTs shall be 18.4 KA for 3 second. CTs shall be double core and dual ratio. Saturation factor for metering core shall not exceed 2.5.
- 1.7.3. The designed accuracy should be available even at the lowest ratios and all CTs shall withstand fault current corresponding to 350 MVA for 3 sec.
- 1.7.4. The secondary terminal of the current transformers shall be such that effective and firm wire terminations are possible. Shorting links of adequate capacity shall be provided at the terminal blocks for sorting of the leads from secondary terminals of current transformers. The secondary terminal of the CTs shall be earthed at one point.
- 1.7.5. The secondary winding resistance of CTs shall be as low as possible but not greater than 0.2 ohms per 100 turns.
- 1.7.6. CTs shall conform to IS 2705 with latest amendment, if any in all respect and will be subjected to all routine and type test specified in the IS.

**1.8. CABLE GLANDS AND CLAMPING ARRANGMENT FOR HOLDING SUITABLE CABLE BOXES**

- 1.8.1. Two nos, brass-wiping glands for each incomer and one no. Brass wiping gland for each outgoing panel of adequate dimension for XLPE cable of 3 cores up to 400 sq. mm size shall be supplied along with panels. For bus coupler no cable glands should be provided.
- 1.8.2. Suitable cable boxes as per requirement of cable shall be arranged by the purchaser at his end. The panel shall however provide a flat of size 50X6 mm<sup>2</sup> with suitable clamp made of 50X6 mm<sup>2</sup> flat along with Nuts Bolts and Washers for holding the cable boxes. The flat should be fitted at a suitable height with allotted arrangement for adjustment of height from 300mm to 500mm at site. The clamp and flat shall have suitable stud type arrangement for earthing cable and cable box.
- 1.8.3. All control cable/wire entries shall be by means of suitable cable glands, such glands shall be of brass and tinned.

**1.9. AUXILIARY/CONTROL WIRING**

All the secondary wiring in the panel shall have high quality PVC insulation and the same shall have conductor size of not less than 2.5 mm<sup>2</sup> of copper. Colours of the secondary/auxiliary wiring should conform to IS 375/1963 and latest amendment thereof if any. All wiring shall be neatly run and group of wiring shall be securely fixed by clips so that wiring can be checked without necessity of removing the clamps. Wiring between fixed and moving portion of the panel shall be run in flexible tubes and the same shall be so mounted to avoid any damage to them due to mechanical movements. Ferrules with number shall be provided on both end of the wiring.

**1.10. MARKING OF PARTS**

For facilitating the erection, the several parts of the plant and equipment shall be suitably marked.

**1.11. NAME PLATE AND DIAGRAM PLATES**

All equipment shall have weather proof and non corrosive metal plates fixed in suitable position with full particulars engraved thereon with white letters against black background.

The firm shall affix a name plate on each Switchgear panel having following information:

1. Manufacturer's name and trade mark.
2. Unique No.
3. Type of Panel.
4. CT Ratio.
5. Rated Voltage.
6. Rated Insulation Level
7. Rated Frequency
8. Rated Normal Current
9. Rated Short Circuit Breaking Current.
10. Weight
11. Specification No.
12. Order No. and Date
13. Year of supply.
14. Property of SEBs

**1.12. PAINTING**

All metallic surface [except enameled and bright parts] exposed to weather shall be given suitable primer coat and two coats of first quality paint of approved colour. The supplier shall also supply adequate quantities of paints, Varnish etc. for use of finished cost and for use of patching up any scratches received during transport, handling erection testing and commissioning.

Instead of above proper powder coating after proper pre treatment is acceptable and in that case earlier condition will not applicable.

**1.13. DETAILED FITTING AND MOUNTING**

Detailed fittings and mountings of equipments in various switchgear panel shall be as follows

**1.13.1. ITEM NO. 1 – INCOMING PANELS RATING; 1250 AMP WITH CT RATIO 600-300/5A or 600-300/1A**

Each unit shall have the fittings and equipments as follows:

- ❖ 1 No steel totally enclosed, fully interlocked, indoor industrial pattern, metal clad, horizontal draw out, vertical/horizontal isolation floor mounting switch unit complete with transportation truck having integral mechanism and all necessary supports each equipped as under:
- 1 No Fabricated sheet steel housing.

- 1 No. Complete set of mechanical interlocks.
- 1 No. Set of isolating plugs and sockets [6 nos. rated for 1250 Amp. With automatic safety shutters and pad locking arrangements. Facilities shall be provided for proper opening of the safety shutter for cleaning, inspection and testing.
- 1 No. 1250 Amp triple pole VCB fitted with isolating sockets, spring operated, manually as well motor charged, manually/ electrically released spring closing mechanism with mechanical ON/OFF indicators suitable for a rupturing capacity of not less than 350 MVA at 11 kV for 3 seconds and fitted with one set of direct acting trip coils suitable for operation with AC series trip relays.
- 1 No. Auxiliary switch with minimum four normally closed and four normally opened contacts. The contact terminals shall be brought out and terminated at Terminal Board irrespective of whether terminals are used or not.
- ❖ 3 Nos. 600-300/5-5 A ratio double core resin cast current transformer of required Accuracy, for protection and metering as per Para 4.7.1 of specification. Alternatively single core dual ratio 5 nos., CTs [3 nos. for protection and 2 nos. for metering] shall also be acceptable.
- ❖ 1 No. Ammeter digital static ammeter suitably scaled and must suit CT ratio.
- ❖ 1 No. 3 phase resin cast, draw out type bus bar connected potential transformers of Ratio 11000/110 volts class 0.5 accuracy having minimum 50 VA output per phase to operate the A.C. static H.T. Tri-vector meter, voltmeter etc. and complete with HT fuse and LT MCB with monitoring contacts.
- ❖ 1 No. Voltmeter round flush pattern digital static suitably scaled to suit the PT ratio.
- ❖ 1 No. 3 way and off voltmeter selector switch for reading the voltage between any two phases on the voltmeter.  
  
1 No. static digital Tri vector energy meter suitable for three phase 3 wire un-balanced load and CT, PT, ratio mentioned above, 0.5 accuracy class with load, survey and TOD/Tariff and MRI facility. TVM shall be as specification attached with this specification.
- ❖ 1 No. Non directional adjustable IDMT series trip O/C relay with definite minimum 3 seconds at 10 times plug setting. The relay shall be arranged for over current protection with setting from 50 to 200% of 5A on all three over current elements mounted in draw out case tropicalised with flag indicator.
- ❖ 1 No. set of indicating lamps operating at 230V AC single phase one coloured RED and other GREEN to show the closed or open position of circuit breaker.
- ❖ 1 No. 80 watts continuously rated tubular/strip type heater with manual ON/OFF switch working on 230 VAC single phase supply.
- ❖ 1 No. set of copper bus bars of not less than 1250 Amp. Continuous rating.
- ❖ 1 No. multi way plug box for secondary wiring between the fix and moving glands.
- ❖ 1 No. set of independently operated automatic shutters for bus bar cable and voltage transformers orifices, which shall be clearly leveled and individually pad-locked.
- ❖ 1 No. Sheet instruments panel mounted on the front of the unit with hinged access doors and totally enclosed wiring terminals mounted there.
- ❖ 1 No. Complete set of self contained inter connectors, foundation bolts, fine Wiring, wiring terminals board, sundries to complete the unit.

**1.13.2. ADDITIONAL FEATURE IN 600-300/ 1A INCOMERS FOR 10 MVA AND HIGHER TRANSFORMERS (Applicable in case of installing 10MVA or above transformer).**

This switchgear shall be used with 10MVA, 33/11 KV Transformer having delta in primary and grounded star in secondary, conventionally differential protections is essential for the transformer. For 11 kV side 3 nos. CTs of 600-300/1 A [Class PS and appropriate knee point voltage] and matching inter posting CTs (if required) shall be provided in this switchgear panel. The mounting inter connection and termination etc. for these additional devices/relays shall be covered in scope of supply.

**1.13.3. CLARIFICATION**

The total requirement of CTs for incomer of ratio 600-300/5A is as follows:

- 3 CTs one for each phase of ratio 600-300/5A to connect to 3 nos., O/C relays.
- 2 nos. CTs one on R phase and other on B phase of ratio 600-300/5 A for metering.

**1.13.4. ITEM NO. 2 OUTGOING FEEDER PANEL WITH CT RATIO 600-300 /5A**

The fittings and mountings shall be similar to item no. 1 above except the following:

- The CT ratio will be 600-300/5A.
- The voltage transformers voltmeter and voltmeter selector switch shall be deleted.
- 3 nos, CT operated overload releases are to be provided.
- 1 no. non directional triple pole adjustable IDMT, combined O/C and E/F [3 no. O/C and 1 no. E/F] AC series trip relay with instantaneous high set trip feature of low transient over reach not exceeding 5% with definite minimum 3 seconds at 10 times plug setting. The relay shall be arranged for over current protection with setting 30-120 % of 5 Amp. And for earth fault protection with setting 10-40 % mounted on a draw out case tropicalised with flag indicators. High set element of O/C shall have setting range of 5 to 20 times the rated current and the E/F elements shall be 2 to 8 times of rated current.

**1.13.5. BUS COUPLER PANEL**

Each unit shall have the fittings and equipment as follows:

- 1 No. All steel totally enclosed fully interlocked indoor industrial pattern, metal clad horizontal draw out, horizontal/vertical isolation, floor mounting switch unit complete with transportation truck having integral circuit breaker mechanism and all necessary supports each equipped as under:
- 1 No. Fabricated sheet steel mounting.
- 1 No. Complete set of mechanical interlocks.
- 1 No. Set of isolating plug and sockets [6 nos. Rated for 1250 Amp.] with automatic safety shutters and pad locking arrangement. Facilities shall be provided for proper opening of the safety shutter for cleaning inspection and testing.
- 1 No. 1250 Amp. Triple pole VCB fitted with isolating sockets, spring operated, manually charged, and manually released spring closing mechanism with mechanical ON/OFF indicators suitable for a rupturing capacity of not less than 350 MVA at 11 kV for 3 second.
- 1 No. A set of Red and Green pigmy lamps for indicating opened and closed position of breaker.
- 1 No. 3 way auxiliary switch with 4 normally closed and eight normally open contacts.

- 1 No. 80 watt. 230 VAC heaters with 6 Amp. Rotary cam switch.
- 1 No. Bus bar chamber with 1250 A rated copper Bus Bars.
- 1 No. A set of self aligning horizontal/vertical isolation type auxiliary plug and sockets.
- 1 No. Sheet steel instrument panel mounted on the front of the unit with hinged across doors and totally enclosed wiring terminals mounted there.
- The panel shall be without any metering protection CTs, cable box, series trip coils, and relays.

The HT chambers [adopter chamber] will be gasketed to make it vermin proof. The gasket shall be as specified in Section-I(Introduction and general technical requirements).

NOTE: Separate spring charging handle shall be provided and supplied with each set of the VCB.

**1.14. ANNUNCIATION SYSTEM**

Alarm annunciation system shall be provided in the control board by means of visual and audible alarm in order to draw the attention of the operator to the abnormal operating conditions or the operation of some protective devices. The annunciation equipment shall be suitable for operation on the voltages specified in this specification i.e. 30 Volt DC for new substation or as existing DC supply system of the utility (This shall be verified by the successful bidder before submission of the drawing for approval).

Audible annunciation for the failure of DC supply to the annunciation system shall be provided and this annunciation shall operate on 240 Volts AC supply. On failure of the DC to the annunciation system for more than 2 or 3 seconds. (adjustable setting), a bell shall sound. A separate push button shall be provided for the cancellation of this audible alarm alone but the facia window shall remain steadily lighted till the supply to annunciation system is restored.

A separate voltage check relay shall be provided to monitor the failure of supply (240V AC) to the scheme mentioned in Clause above. If the failure of supply exists for more than 2 to 3 seconds. this relay shall initiate visual and audible annunciation. This annunciation shall operate on Annunciation DC and buzzer shall sound.

**1.15. TESTS**

The design of circuit breaker shall be proven through all the routine and in accordance with IS 13118: 1991/IEC 56 and any amendment thereof. Photocopy of all the test reports must be enclosed with the tender. Type test report earlier than 7 year from the date of tender opening shall not be acceptable.

**TYPE TESTS:**

Each circuit breaker shall comply with requirements of type tests prescribed in IEC publication No.56.

- i. Short time and peak withstand current test.
- ii. Short circuit breaking capacity and making capacity.
- iii. Capacitive current switching test: Cable charging current breaking test (Ur less than or equal to 52 kV).
- iv. Dielectric test i.e., power frequency withstand and impulse withstand test
- v. Temperature rise test.
- vi. Mechanical Endurance Test at ambient temperature.
- vii. Measurement of resistance of the main circuit.

viii. Internal arc test.

**1.16. COMMISSIONING CHECKS/TESTS**

After installation of panels, power and Control wiring and connect Contractor shall perform commissioning checks. as listed below to proper operation of switchgear/panels and correctness of all respects.

In addition the Contractor shall carry out all other checks and tests recommended by the manufacturers.

**1.16.1. GENERAL**

- i) Check name plate details according to specification.
- ii) Check for physical damage
- iii) Check tightens of all bolts, clamps and connecting terminal
- iv) Check earth connections.
- v) Check cleanliness of insulators and bushings.
- vi) Check heaters are provided.
- vii) H.V. test on complete switchboard with CT & breaker/ contractor lubricated in position.
- viii) Check all moving Parts are properly lubricated.
- ix) Check for alignment of busbars with the insulators to ensure alignment and fitness of insulators.
- x) Check for inter changeability of breakers.
- xi) Check continuity and IR value of space heater.
- xii) Check earth continuity of the complete switchgear board.

**1.16.2. CIRCUIT BREAKER**

- i) Check alignment of trucks for free movement.
- ii) Check correct operation of shutters.
- iii) Check slow closing operation (if provided).
- iv) Check control wiring for correctness of connections, continuity and IR values.
- v) Manual operation of breakers completely assembled.
- vi) Power closing/opening operation, manually and electrically at extreme condition of control supply voltage.
- vii) Closing and tripping time.
- viii) Trip free and anti-pumping operation.
- ix) IR values, resistance and minimum pick up voltage of coils.

- x) Simultaneous closing of all the three phases.
- xi) Check electrical and mechanical inter locks provided.
- xii) Checks on spring charging motor, correct operation of limit switches and time of charging.
- xiii) Check vacuum (as applicable).
- xiv) All functional checks.

**1.16.3. Current Transformers**

- i) Megger between windings and winding terminals to body.
- ii) Polarity tests.
  - a. Ratio identification checking of all ratios on all cores by primary injection of current.
  - b. Magnetization characteristics & secondary winding resistance.
- iii) Spare CT cores, if any to be shorted and earthed.

**1.16.4. VOLTAGE TRANSFORMERS**

- i) Insulation resistance
- ii) Ratio test on all cores.
- iii) Polarity test
- iv) Line connections as per connection diagram.

**1.16.5. CUBICLE WIRING**

- i) Check all switch developments.
- ii) It should be ensured that the wiring is as per relevant drawings. All interconnections between panels shall similarly be checked.
- iii) All the wires shall be meggered to earth.
- iv) Functional checking of all control circuit e.g. closing, tripping, interlock, supervision and alarm circuit including proper functioning of component/ equipment .
- v) Check terminations and connections. To check wiring related to CT and PT circuits, carryout primary injection and then check for secondary value at relay and metering instrument terminals.
- vi) Wire ducting.
- vii) Gap sealing and cable bunching

**1.16.6. RELAYS**

- i) Check internal wiring.



- ii) Megger all terminal body.
- iii) Megger AC to DC terminals
- iv) Check operating characteristics by secondary injection.
- v) Check minimum pick up voltage of DC coils.
- vi) Check operation of electrical/ mechanical targets.
- vii) Check CT connections with particular reference to their polarities for differential type relays.
- viii) Relay settings.

1.16.7. **METERS**

- i) Megger all insulated portion.

Check CT & VT connections with particular reference to their polarities for power type meter.

**9. Control & Relay Panel for 33kV Feeder with Directional or Non-directional O/C and E/F protection and 33/11kV Transformer Panel with & without Differential Protection for various 33/11 kV Sub-Stations**

1.0 Scope:

This specification covers design, manufacture, assembly, testing before supply, inspection, packing and delivery and other basic technical requirements in respect of control and relay panels for 33 kV feeders, 33/11kV Power Transformers without differential protection and 33/11kV Power Transformers with differential protection to be installed at various 33/11kV sub-stations. The equipment to be supplied against this specification is required for vital installations where continuity of service is very important. The design, materials and manufacture of the equipments shall, therefore, be of the highest order to ensure continuous and trouble-free service over the years. The Manufacturer has to design the Schematics for protection and Control of all equipments including monitoring indications, visual and audible alarm, interlocking schemes among different equipment. Any other requirement which are not specifically covered here but which are necessary for successful commissioning of the Substations are also within the scope of the Contract.

The equipment manufactured should conform to the relevant standards and of highest quality of engineering design and workmanship. The equipment manufactured shall ensure satisfactory and reliable performance throughout the service life. The Schedule of requirement of the Panel is furnished separately in details.

2.0 Service Conditions:

2.1. System particulars:

Nominal system voltage	33kV & 11kV
Corresponding highest system voltage	36kV & 12kV
Frequency	50 Hz ± 3%
Number of phases	3
Neutral earthing	33kV Grounded through Earthing Transformer 11kV solidly earthed

2.2. Equipments supplied against the specifications shall be suitable for satisfactory operation under the following tropical conditions: -

Max. ambient air temperature	60°C
Max. relative humidity	100%
Max. annual rainfall	1450mm
Max. wind pressure	150kg/sq.m.
Max. altitude above mean sea level	1500mtrs.
Isoceraunic level	50
Reference Ambient Temperature for temperature rise	50 degC
Climatic Condition	Moderately hot and humid tropical climate conducive to rust and fungus growth

- 2.3. The climatic conditions are prone to wide variations in ambient conditions and hence the equipments shall be of suitable design to work satisfactorily under these conditions.
- 2.4. Auxiliary supplies available at the various sub-stations are as follows:-

3.2.1 Rating:

	A. C. Supply	230volts, with $\pm 10\%$ variation, Frequency 50Hz with $\pm 3\%$
	D.C. Supply	30VDC. DC system is 2 (two) wire with necessary earth fault annunciator scheme. DC supply shall be normally fed from Battery charger. In case of failure of AC supply to Battery Charger, DC supply voltage will be available from Lead Acid Battery.

- 2.5. Unless otherwise specified all equipment and material shall conform to the latest IS applicable standards. Equipment complying with other internationally recognized standards will also be considered if it ensures performance equivalent or superior to Indian standards. In the event of supply of equipment conforming to any international \internationally recognized standards other than the standard listed below.
- 2.6. The equipment provided shall also comply with the latest revisions of Indian Electricity act and Indian Electricity rules and any other applicable statutory provisions, rules and regulations.
- 2.7. All equipment provided under the specification shall generally conform to the latest issue of the following:-

a)	IS 12063/1987	Degree of Protection provided for enclosure of electrical equipment.
b)	IS 5/2004	Colour for ready mixed paints & enamels.
c)	IS 3231/1986 & 1987	Electrical relays for power system protection
d)	IEC 60255	Numerical biased protection relay
d)	IS 8686/1977	Static Protective Relays
e)	IS 1248/2003	Indicating instruments
f)	IS 14697/1999	HT Static Tri vector TOE Energy meter
g)	IS 6875 amended upto date	Control switches
h)	IS 4794/1968 & 1986	Push buttons
i)	IEC 337 & 337-1	Control Switches (LV Switching devices for control and auxiliary circuit)
j)	IEC: 60185	Current Transformers
k)	IEC: 60186	Voltage Transformer
l)	IS 375	Marking and arrangement for Switchgear Bus
m)	IS: 5578/1984	Marking of insulated conductors.

2.8. CT, PTRatio and Transformer Details:-

CIRCUIT	33KVCT RATIO/CLASS
33Kv Feeder	400-200/1-1A 0.5, 5P20
33kv side of 33/11kv transformer	400-200/1- 1-1A, for 10&12MVA 0.5/5P20/PS and 200-100/1-1A For up to 6.3MVA Tr. 0.5/5P20
11KV side CT for 6.3MVA & 10MVA Transformer	600-400/1-1-1A, 0.5/5P20/PS at phase side (Indoor Panel)
11KV transformer Bushing CT for REF	600/1A, PS for 10MVA 33/11KV transformer for both Phase & neutral. 400/1A, PS for up to 6.3MVA 33/11KV transformer for only neutral.
33KV PTRATIO	33KV, single phase
Electro-magnetic PTRatio/Class	33KV/ $\sqrt{3}$ , 110V/ $\sqrt{3}$ -110V/ $\sqrt{3}$ , 0.5/3P
TRANSFORMER DETAILS	33/11KV, up to 12MVA, Dyn11

3.0 CONSTRUCTIONAL DETAILS:

3.1. CONTROL AND RELAY PANEL

The Control and Relay Panel shall be of Simplex type and the access door shall be provided at the back of each Panel where no instruments or relays shall be mounted. The indicating and signaling devices and relay set c. shall be mounted on the front side and the auxiliaries which shall be inside the Panel. The access door shall be at the back side and of double door type of height 1900mm.

In front of Panel where relays and instruments are to be mounted shall be stretcher leveled steel plate 3 mm. thick and side panel, doors and top covers shall be of 2mm. thick steel plate. Light section of structural steel shall be used for panel frame.

The individual panel shall be 2250mm. in height with Channel base, 610mm. in depth and of suitable width limited to 1000mm to accommodate the equipment at a suitable height, suitable gap to facilitate easy workability as specified hereafter. Individual piece of Channel base of C&R Panel is to be provided to obtain the flexibility of inter-changing the Panel, if any.

The complete panel shall incorporate all necessary instruments, meters, relays, auxiliary relays, control switches, indicating lamps, mimic, annunciator, audible alarms, horizontal and vertical wiring trough, wiring supports, interior lighting system, terminal blocks, fuses and link set c.

3.2. CONSTRUCTIONAL FEATURES

- a. The Control and Relay Panel frames shall be suitable for erection on flush concrete floor and secured to it by means of evenly spaced grout bolt projecting through the base channels from members of the frame.
- b. The manufacturers shall ensure that the equipments specified and such unspecified complementary equipment required for completeness of protection/control scheme be properly accommodated in the panels without congestion and if necessary to provide panels with larger width. No price increase at a later date on this account shall be allowed.
- c. Panels shall be completely metal enclosed and shall be dust, moisture and vermin proof for tropical use. The enclosure shall provide a degree of protection not less than IP-41 in accordance with IS-2147. Type test report in this respect shall be furnished with offer.
- d. Panels shall be free standing, floor mounting type and shall comprise structural

frames enclosed completely with specially selected smooth finished, cold rolled sheet steel of thickness not less than 3mm for weight bearing members of panels such as base frame, front sheets and door frames and not less than 2mm for sides, door, top & bottom portions. There shall be sufficient reinforcement to provide level surfaces, resistance to vibration and rigidity during transportation and installation.

- e. Design, material selection and workmanship shall be such as to result in neat appearance, inside and outside with no welds, rivets or bolt head apparent front outside, with all exterior surfaces true and smooth.
- f. All holes and extension windows in the Panel shall be blanked and access doors shall be lined with compressible liners at the edges. The EMPLOYER will shut off the bottom crevices with cream cement, the Cable Entry holes with weak concrete and the cable trench with present R.C. Slabs or checker plate. All control and supply cables will be laid in a distribution trench running under the panel. The Cable will branch off into each cubicle through entry holes in the concrete floor opening in the bottom cubicles. Necessary Drawings for concrete floor and trench shall be supplied by the manufacturer to enable the EMPLOYER to construct the foundation floor for these panels. The drawings shall show details of the distributing trench, cable entry holes, glands and positions of grouting bolts. The EMPLOYER will prepare foundation with pocket for grouting bolts. The manufacturer shall supply channel base, suitable grouting bolts, locknut and washers.
- g. Control Cable entries to the panel shall be from the bottom. Bottom plates of the panels shall be fitted with detachable gland plates to allow cable entries from the bottom. Gland plates shall be suitable for fixing the cable glands at an elevated height of at least 100mm above the ground level. Terminal Connectors and Test terminal blocks for cables shall be fixed at an elevated height of at least 200mm above the Bottom plate. Side block cutout to be arranged at the top of both sides of panel for inter panel bus wires. Dimension of the cutout will be 300 mm X 50mm, 255mm from the top.

3.2.1 General:

- a. Materials shall be new; the best quality of their respective kinds and such as are usual and suitable for work of like character. All materials shall comply with the latest issues of the specified standard unless otherwise specified or permitted by EMPLOYER.
- b. Workmanship shall be of the highest class throughout to ensure reliable and vibration free operations. The design, dimensions and materials of all parts shall be such that the stresses to which they may be subjected shall not cause distortion, undue wear, or damage under the most severe conditions encountered in service.
- c. All parts shall conform to the dimensions shown and shall be built in accordance with approved drawings. All joints, datum surfaces and meeting components shall be machined and all castings shall be spot faced for nuts. All machined finishes shall be shown on the drawings. All screw, bolts, studs and nuts and threads for pipes shall conform to the latest standards of the International Organization for Standardization covering these components and shall all conform to the standards for metric sizes.
- d. All materials and work that have cracks, flaws or other defects or inferior workmanship will be rejected by EMPLOYER.

3.2.2 Assembly:-

Necessary items of equipment shall be assembled in the factory prior to shipment and routine tests shall be performed by the manufacturer as per the requirements of the latest issue of IEC/IS as specified under each equipment in these specifications to demonstrate to the satisfaction of EMPLOYER that the switch gear panels comply with the requirements of the relevant IEC/IS standards.

3.2.3 Casting:-

Castings shall be true to pattern, of workman like finish and of uniform quality and condition, free from blow holes, porosity, hard spots, shrinkage defects, cracks or other injurious defects, shall be satisfactorily cleaned for their intended purpose.

3.2.4 **Welding:-**  
 Wherever welding is specified or permitted, a welding process, including stress relief treatment as required if necessary, conforming to an appropriate and widely recognized professional standard shall be used. All welders and welding operators shall be fully qualified by such a standard.

#### 4.0 Mounting

9.1 All equipment on and inside the panel shall be mounted and completely wired to the terminal blocks ready for external connection.

9.2 Equipment shall be mounted such that removal and replacement can be accomplished individually without interruption of service to adjacent devices and are readily accessible without use of special tools. Terminal markings shall be clearly visible and of permanent nature.

9.3 The manufacturer shall carry out cutout, mounting and wiring of the bought out items which are to be mounted in the panel in accordance with the corresponding equipment manufacturer's drawings.

9.4 The centre line of switches, push buttons and indicating lamps shall be not less than 750 mm from the bottom of the panel. The centre line of relays and meters and recorders shall be not less than 450 mm from the bottom of the panel.

9.5 The centre lines of switches, push buttons and indicating lamps shall be matched to give a neat and uniform appearance. Likewise the top of all meters, relays and recorders etc. shall be in one line.

9.6 The control switches for circuit breakers shall be located on the mimic diagram corresponding to their exact position of the controlled equipment in the single line drawing. The location of the switches shall be within working height from the floor level for easy and comfortable operation.

9.7 No equipment shall be mounted on the doors.

9.8 All the equipment connections and cabling shall be designed and arranged to minimise the risk of fire and damage.

The constructional details and mounting arrangement for various front mounted equipments shall be as per the enclosed drawings. The center lines of any relays, if additionally provided, shall not be less than 450 mm from ground level.

#### 5.0 WIRING

5.1 All wirings shall be carried out with 1100 volt grade single core, multi strand flexible tinned copper wires with PVC insulation which has provided its utility in tropical region against hot and moist climate and vermin (Misc. white ants and cockroaches etc.) Rubber insulated wiring will not be accepted. Wire numberings and colour code for wirings shall be as per IS: 5578/1984. The wirings should be encased in suitable width PVC casing. The wiring diagram for various schematics shall be made on thick and laminated durable white paper in permanent black ink and same should be pasted on the inside surface of the door.

5.2 The sizes of wiring in different circuits shall not be less than those specified below:

TABLE-I

Circuit	Permissible size of wire
Metering and Relaying Circuits connected Current Transformer	2.5mm <sup>2</sup>
Potential Circuits for metering and Relaying, Control, Visual Audible Alarms and Signalling Circuit	1.5mm <sup>2</sup>

The following colour scheme shall be used for the wiring:

TABLE- II

Circuit where used	Colour of Wire
Red Phase of Instrument Transformer Circuits	Red
Yellow Phase of Instrument Transformer Circuits	Yellow
Blue Phase of Instrument Transformer Circuits	Blue
Neutral connection, earthed or not earthed in the instrument Transformer Circuit	Black
A.C. Control Wiring Circuits using auxiliary supply and	Black
D.C. Control Wiring Circuit using Battery Supply	Grey
Earth Connection	Green

5.3

- a) All internal wiring shall be securely supported, neatly arranged, readily accessible and connected to equipment terminals and terminal blocks. Wiring gutters & trough shall be used for this purpose.
- b) Longitudinal trough extending throughout the full length of the panel shall be used for inter panel wiring. Interconnection to adjacent panels shall be brought out to a separate set of terminal block wires. All bus wiring for inter panel connection shall preferably be provided near the top of the panels running throughout the entire length of the panels.
- c) Wiring connected to the space heaters in the cubicles shall have porcelain beaded insulation over a safe length from the heater terminals.
- d) Wire termination shall be made with solder less crimping type and tinned copper lugs which firmly grip the conductor and insulation. Insulated sleeves shall be provided to all the wire terminations. Engraved core identification plastic ferrules marked to correspond with panel wiring diagram shall be fitted at both ends of each wire. Ferrules shall fit tightly on the wire and shall not fall off when the wire is disconnected for any purpose. Termination shall be such that no strand of a conductor shall be left loose or overhanging. Conductor terminations shall be secured to the holding nuts/screws, terminal block set c. with washers interposed between the terminals/holding nuts/screw heads. The terminals shall be so connected that no conductor or ferrule code gets masked due to overlay of conductors.
- e) All spare contacts of relays shall be wired up to terminal blocks.
- f) Each wire shall be continuous from end to end and shall not have any joint within itself individually.
- g) Wires shall be connected only at the connection terminals or studs of the terminal blocks, meters, relays, instruments and other panel devices.

Terminal Ends of all wires shall be provided with numbered Ferrules. At point of inter-connection where a change of number is necessary, duplicate Ferrules shall be provided with the appropriate number on the changing end.

- h) At the terminal connection, washers shall be interposed between terminals, wire terminals and the holding nuts. All holding nuts shall be secured by locking nuts. The connection stud shall project at least 6mm from the lock nut surface. Wire ends shall be so connected at the terminal studs that no wire terminal numbered ferrule gets masked due to succeeding connections. All wires shall be suitable for bending to meet the terminal stud at right angles with the stud axis, and they shall not be skewed.
- i) All studs, nuts, bolts, screw sets, etc. shall be threaded according to the British Standard practice unless EMPLOYER's prior approval to any other practice of threading is obtained.

**6.0 TERMINAL BLOCK CONNECTION**

Terminal blocks shall be of clip-on design made out of non-trackable insulating material of 1100V grade. All terminals shall be stud type, with all current carrying and live parts made of tinned plated brass. The studs shall be of min 4mm dia brass. The washers, nuts, etc. used for terminal connectors shall also be of tinned plated brass. All blocks shall be shrouded by easily removable shrouds made of transparent dielectric materials.

The terminal connector/block shall be disconnecting type terminal connectors for PT and same with automatic shorting of C.T. secondary terminals shall be provided in CT secondary circuit. All other terminal connectors shall be Non-disconnecting type. Terminals should be shock protected in single moulded piece. Terminal block should have screw locking design to prevent loosening of conductor. Provisions shall be made on each pillar, for holding 10% extra connection (5% incoming + 5% outgoing).

At least 20% spare terminals for each type shall be provided. All terminals shall be provided with ferrules indelibly marked or numbered and identification shall correspond to the designations on the relevant wiring diagrams. The terminals shall be rated for adequate capacity which shall not be less than 10 Amps for control circuit. For power circuit it shall not be less than 15 Amps.

**7.0 SPACE FOR CONTROL CABLES AND CABLE GLANDS**

Sufficient space for receiving the Control Cables inside the Panel at the bottom of the cubicles and mounting arrangement for the terminal cable glands shall be provided. Removable type separate cable entry plate (may be two) shall be fixed with bottom plate. This specification does not cover supply of control cables and cable glands for which the EMPLOYER will make separate arrangement.

**8.0 SPACE HEATERS**

240V, 50HZ Tubular Space Heaters suitable for connection to the Single Phase A.C. Supply complete with On-Off Switches located at convenient positions shall be provided at the bottom of the Panel to prevent condensation of moisture. The Watt loss per unit surface of heaters shall be low enough to keep surface temperature well below sensible heat. A thermostat control unit with variable temperature shall be installed to control the heater. The 240V AC supply for the heaters shall be controlled by a suitably rated single pole miniature circuit breaker compartment to be mounted on an insulator. One AC Ammeter with 0-1.0A range shall be provided in series with the heater to monitor the current draw of the Heater.

**9.0 DISTRIBUTION AND CONTROL OF AUX. POWER CIRCUIT**  
**9.1. D.C. CIRCUIT**

There shall be only one 30V D.C. for the entire Control and Relay Panel fed from a D.C. Distribution Panel. A continuous D.C. Bus shall be provided in the Control and Relay Panel and D.C. supply for control, protection, indication and supervision of circuit breaker and



other equipments shall be tied off from D.C. bus through a set of 20 Amp rated H.R.C. Fuse on positive and negative side. D.C. supply to be tied off shall be distributed within the Panel as below:

- (a) Control DC scheme both positive and negative side with 16 Amp fuse
- (b) Close/Trip Ckt 1 and Trip Ckt 2 without fuse; closing circuit with 10 A fuse.
- (c) Indication Circuit through a set of 6 Amp. HRC Fuse both at +ve and -ve side
- (d) Protective relay circuits through 6 A fuse both at +ve and -ve side
- (e) Annunciation ckt with 6 Amp fuse on both at +ve and -ve side
- (f) DC Emergency Lamp with 6 Amp fuse both at +ve and -ve side

Three nos. of D.C. operated no-volt auxiliary relay (self reset type) provided with hand reset type flag with inscription – Main D.C. Fail, \_Control Dc fail & Protection DC fail with 4NO+4NC in each relay. 2 NC contact for \_DC fail alarm and Indication, 1NO wired upto SCADA TB and 1NO wired upto spare TB.

One Push button having N/C Contact used in Series with the above relay for \_D.C. Fall Test purpose.

#### 9.2. A.C. CIRCUITS

230 Volts, Single Phase A.C. Aux. Supply to the Control and Relay Panel will be fed from A.C. Distribution Panel through a 16 Amp MCB provided there. One 16 Amp rated HRC Fuse shall be provided at the Control & Relay Panel for the Incoming A.C. Supply. Two A.C. operated no-volt auxiliary relay (self reset type) rated for 230V shall be provided with hand reset flag with inscription – A.C. Fail & DC Fail Accept with 4NO+4NC contacts for each relay. One push button having N/C Contact used in Series with a over relay for – A.C. Fail Test purpose.

#### 9.3. P.T. SECONDARY CIRCUIT

There may be two nos. 33KV bus PT, one in each bus section. P.T. supply shall be available from selected 33KV Bus P.T. through suitable PT selection scheme by switch. Two sets of Fuse and link of suitable rating shall be provided for the Incoming P.T. supplies and two sets, one for each PT of 3 nos. coloured LED indicating lamp shall be provided for supervision of the Fuse. Lamp shall be connected between respective phases and neutral. The arrangement of distribution of P.T. Secondary Circuit shall be as follows:

- (a) Potential supply to the protective relay circuit for Feeder where necessary shall be fed from selected Bus P.T. supply bus.
- (b) Potential supply to meters, Energy meters and indicating instrument of each panel shall be fed from selected Bus P.T. supply bus.
- (c) Selected P.T. secondary supply to the protective relays of each panel shall be fed through 4 poles-MCB and link in neutral in each panel where necessary with two changeover contacts for annunciation.
- (d) Selected P.T. secondary supply for metering and indicating instruments of each panel shall be fed through 4 pole MCB in each phase and link in neutral in each panel of 33KV system voltage.
- (e) Two position (PT-1/PT-2), minimum 4 (four) way PT selector switch (stay put type), minimum 16 A ratings shall be provided in each panel for metering ckt. Additional 4 way PT selector switch is required for protection wherever applicable. The no. of way may increase during detailed engineering.

#### 9.4. FUSE AND LINK

Fuses shall be of cartridge type. Carrier and base for the fuse and links for all D.C. and A.C. Circuits shall have imprint of rating, voltage and circuit designation.

9.5. MIMIC DIAGRAMS

a) Provisions shall be made for 10mm wide painted and overall drawing mimic diagram by the EMPLOYER on the exterior of the front panel to represent the single line arrangement of the station equipment. Provisions shall be made in such a way that centre line of the mimic bus shall be at a suitable height from the bottom of the C&R Panel.

b) Colour scheme for mimic diagrams as follows:-

KV Class	Colour	Shade Index as per ISS
33KV	Brilliant green	221
11KV	Air Craft blue	108
400/230V	Black	309
Earth	White	-
110V	Canary yellow	-

c) In 33KV simplex type C&R panels, symbol marking for the position indication of isolators, earth switches etc, ON/OFF indication for Circuit breaker, PT supply indication, CB spring charge, auto trip, trip lock etc shall be mounted along the mimic diagram at appropriate location. Non-Discrepancy type control switch for the C.B. shall be mounted within the mimic, indicating the C.B. ON/OFF status.

10.0 Labeling

All front mounted as well as internally mounted items including MCBs shall be provided with individual identification labels. Labels shall be mounted directly below the respective equipment and shall clearly indicate the equipment designation. Labelling shall be on aluminium anodised plates of 1mm thickness, letters are to be properly engraved.

11.0 Earth Bus

Each panel shall be provided with two earth bus of size 25x6mm (min) each. The earth bus shall be of tinned plated copper, and all metallic cases of relays, instruments etc shall be connected to this earth bus independently for their effective earthing. The wire used for earth connections shall have green insulation.

12.0 Circuit breaker Control Switch:

19.1 PISTOL GRIP TYPE Non-discrepancy T-N-C spring return type switch shall be provided for remote operation of circuit breaker to ensure that manual pumping of closing solenoid is not possible. The switch shall be mounted in the mimic diagram itself such that the stay-put ('N') position will render the continuity of the mimic. One green LED for 'breaker open' indication and one red LED for 'breaker closed' indication shall also be provided adjacent to the T-N-C switch.

19.2 Switches should have fingertouch proof terminals. For the convenience of maintenance, screw driver guides should be from top/bottom of the switch and not from the side. Terminal wire should be inserted from the side of the switch terminal.

19.3 Terminal screws must be captive to avoid misplace during maintenance.

19.4 Switch shall be with 48 mm x 48 mm escutcheon plate marked with Trip & Close.

19.5 Trip-neutral-close, with pistol grip handle must be pushed into spring return to either trip or close position from Neutral position for safety and not just turn to trip.

- 19.6 Onecontactto closein eachpositionofTripand Close.Contactratingshallbe 12Aat 30VDC.  
 19.7 Onesparescontactisrequiredin off &onposition.

13.0 Local/Remoteswitch:

Local/Remoteswitchshouldbe4-pole,2wayLockableandstayputtype.

14.0 INDICATINGLAMPS &CONTACTMULTIPLIER

i) INDICATINGLAMPS

L.E.D.TypeIndicatingLampsshallbeprovidedontheControlPaneltoindicate the following:

S.No.	Functions	Quantity	Colour of Lamp
1	C.B. Spring charged indication	1 No.	Blue
2	C.B. trip Coil/Circuit healthy indication	2 No.	White
3	C.B. Auto tripped indication	1 No.	Amber
4	Panel D.C. Fail indication	1 No.	Amber
5	P.T. Supply indicating Lamp	2 sets	Red/Yellow/Blue
6	C.B. —ON indication	1 No.	Red
7	C.B. —OFF indication	1 No.	Green

AllthelampsshallbeconnectedtotheauxiliaryD.C.supplyoftheSub-StationexceptSI.No. (4)&SI.No.(5)whichshouldbeconnected totheauxiliaryA.C.supplyandP.T.Secondary supplyrespectively. TheLampshallbesuitable forPanelpurposeandshallbeLowWatt consumption. Allindicatorsshall havebrightLEDs having longlife.Conventionalbulbsarenot acceptable. TheindicatingLEDswithresistorsshallwithstand120%ofratedvoltageona continuousbasis.However, thisspecification ofindicatinglampsmaylikelytobechanged/ modifiedasperrequirementof EMPLOYER.

Lamps for circuit breaker "ON", "OFF", "TRIP CKT HEALTHY" and "AUTO TRIP" indications. LED indicating lamp complete with static circuits and features should be supplied with Low voltage protection circuit (LVGP) and surge suppressor circuit having LED indication. Lamp assembly should be of fire – retardant glass epoxy PCB , industrial heat resistant, fire resistant, non hygroscopic DMC material, chrome – plated corrosion resistant solid brass bezel, polycarbonate lens in desired colour shades of Red, Green , Amber, Yellow etc. the intensity of light should be minimum 100 mcd at 20 mA . Indication lamp should be suitable to operate on 30 V direct current supply source. Acceptable make are BINAY Opto Electronic Private Ltd. or equipment.

ii) ContactMultiplier

230Volts,SinglePhase,50hzA.C..Supplyoperated Contact Multipliertobeprovided, if required.

15.0 TERMINALBLOCK/TTB

1. TerminalBlocksforincomingA.Cand D.C.CircuitandC.T.,P.T. &SCADACircuitsshould belocatedon the lefthandsideandTransformersupervision,breakercontrolandsparein right handsideof thewallof thePanelseenfrombacksiderespectively.
2. 3-Phase,4-WireLinktypeTestTerminalBlockhavingsealingprovisionshallbeprovidedin MeteringCircuitof eachPanel.

16.0 SAFETY EARTHING

1. Earthing of metallic parts or metallic bodies of the equipment on the Panel shall be done with soft drawn single conductor bare Copper Tail connections shall have minimum area of 16 sq. mm. and the main earthing connection 60 sq. mm. These wires shall be connected by suitable terminals and clamps junction. Soldered connections shall not be employed.
2. The neutral point of star connected LV winding of instrument transformers and one corner of the open delta connected LV side of instrument transformers shall be similarly earthed by tail connected with main earth wire of Panel Earthing System. Multiple earthing of any instrument transformer circuit shall be avoided.

17.0 PANELLIGHTING

1. The Panel interior shall be illuminated by CFL lamps connected to 230 Volt Single Phase A.C. The illumination of the interior shall be free from shadows and shall be planned to avoid any strain or fatigue to the wireman likely to be caused due to sub-normal or non-uniform illumination. One emergency D.C. light shall be provided for each panel with individual switch with proper identification mark.
2. A toggle switch or door operated switch shall be provided for control of A.C. lighting in each panel.
3. One combined 15 Amps. 3-Pin and 5 Amps. 2-Pin Power Socket outlet together with Plus Pin shall be provided at convenient points in each Panel for A.C. Supply.

18.0 ANNUNCIATOR

A. ELECTRONIC ANNUNCIATOR

1. Suitable Multi-way Microprocessor based electronic Annunciator for the visual and audible alarm on the control panel using bright LED shall be provided in each panel to indicate over current and earth fault protection operated. In addition to above, each electronic annunciator of Transformer Control Panel shall have provision to indicate Transformer trouble trip/alarm function operated. Also one window of the Annunciator shall have to be used for Non-Trip A.C. Fail Alarm Indication and one window for Trip Circuit unhealthy indication. Each Electronic Annunciator shall have provision for connection with accept/reset/lamp test/mute Push buttons for proper functions. Electronic annunciator shall have provision for connection with Electronic Buzzer/Electronic Bell for Trip & Non-Trip Audio Alarm of common annunciation scheme. Electronic Annunciation shall have provision for flashing illuminating display with inscription for operation of respective Protection Relay. The Micro-Processor based Electronic Annunciator should have separate coloured windows for Trip & Non-Trip Annunciation for easy detection.
2. Annunciator fascia units shall have translucent plastic windows for each alarm point.
3. Electronic Annunciator shall have first Fault Indication Facilities & System Watch Dog
4. Annunciator fascia plates shall be engraved in black lettering with respective alarm inscription as specified. Alarm inscription shall be engraved on each window in not more than three lines and size of the lettering shall be about 5mm. The inscriptions shall be visible only when the respective fascia LED will glow.
5. Annunciator fascia unit shall be suitable for flush mounting on panels. Replacement of individual fascia inscription plate and LED shall be possible from front of the panel.
6. Unless otherwise specified, one alarm buzzer meant for non-trip alarms and one bell meant for trip alarms shall be provided in each control panel (mounted inside).

7. Each annunciator shall be provided with 'Accept', 'Reset' and 'Test' push buttons, in addition to external PB.
  8. Special precautions shall be taken by the manufacturer to ensure that spurious alarm conditions do not appear due to influence of external magnetic fields on the annunciator wiring and switching disturbances from the neighbouring circuits within the panels.
  9. In case 'RESET' push button is pressed before abnormality is cleared, the LEDs shall continue to glow steadily and shall go out only when normal condition is restored.
  10. Any new annunciation appearing after the operation of 'Accept' for previous annunciation, shall provide a fresh audible alarm with accompanied visual alarm, even if the process of "acknowledging" or "resetting" of previous alarm is going on or is yet to be carried out.
- B. Provision for testing healthiness of visual and audible alarm circuits of annunciator shall be available.

16 Window Annunciation Scheme for 10 MVA & 12 MVA Transformer (individually controlled) to indicate following functions:-		
1	Differential protection (87) operated	1 no.
2	Non-directional protection (O/C+E/F) operated	1 no.
3	Oil Temp./Winding Temp/MOG Alarm for transformer	1 no.
4	Oil Temp./Winding Temp Trip for transformer	1 no.
5	REF64R (HV side) tripped	1 no.
6	REF164R (LV side) tripped	1 no.
7	Buchholz Alarm for transformer	1 no.
8	Buchholz Trip for transformer	1 no.
9	OLTC Buchholz/Main Tank PRV Trip for transformer	1 no.
10	AC fail	1 no.
11	Trip Circuit/Coil 1 or Trip Circuit/Coil 2 Unhealthy	1 no.
12	Non-directional O/C & E/F Relay Trouble	1 no.
13	Differential relay trouble	1 no.
14	Spare	1 no.
15	Spare	1 no.
16	Spare	1 no.
Mounting		Flush
No. of face windows		16
Supply voltage		30VDC
No. of LEDs per window		2
Lettering on face plate		Properly engraved

12 Window Annunciation Scheme for up to 6.3 MVA Transformer (individually controlled) to indicate following functions:-		
i)	Non-directional protection (O/C+E/F) operated	1 no.
ii)	Oil Temp./Winding Temp/MOG Alarm for transformer	1 no.
iii)	Oil Temp./Winding Temp Trip for transformer	1 no.
iv)	REF64R (HV side) tripped	1 no.
v)	REF164R (LV side) tripped	1 no.

vi)	BuchholzAlarmfortransformer	1 no.
vii)	BuchholzTripfortransformer	1 no.
viii)	OLTCBuchholz/Main TankPRVTripfortransformer	1 no.
ix)	PanelACfail	1 no.
x)	TripCircuit/Coil1orTripCircuit/Coil2Unhealthy	1 no.
xi)	PanelACfail	1 no.
xii)	Non-directionalO/C&E/FRelayTrouble	1 no.
xiii)	Spare	1 no.
Mounting		Flush
No. of faciawindows		12
Supplyvoltage		30 V DC
No. of LEDsperwindow		2
Letteringonfaciaplate		Properly engraved

12WindowAnnunciationSchemeforFeederstoindicatefollowing functions:-		
i)	Non-directionalO/C operated	1 No
ii)	Non-directionalE/F operated	1 No
iii)	PanelD.C.Fail	1 No
iv)	TripCircuitCoil2Unhealthy	1 no.
v)	PanelACfail	1 no.
vi)	TripCircuit/Coil1Unhealthy	1 no.
vii)	Non-directionalO/C&E/FRelayTrouble	1 no.
viii)	PT MCBTripped	1 No
ix)	Spare	1 no
x)	Spare	1 no.
xi)	Spare	1 no.
xii)	Spare	1 no.
Mounting		Flush
No. of faciawindows		12
Supplyvoltage		30 V DC
No. of LEDsperwindow		2
Letteringonfaciaplate		Properly engraved

12 Window Annunciation Scheme for Parallel Feeders to indicate followingfunctions:-		
i)	Directional O/C operated	1 no.
ii)	Directional E/F operated	1 no.
iii)	Panel DC Fail	1 no.
iv)	Trip Circuit/Coil 2 Unhealthy	1 no.

v)	Panel AC fail	1 no.
vi)	Trip Circuit/Coil 1 Unhealthy	1 no.
vii)	Directional O/C & E/F Relay Trouble	1 no.
viii)	PT MCB Tripped	1 no.
ix)	Spare	1 no.
x)	Spare	1 no.
xi)	Spare	1 no.
xii)	Spare	1 no.
Mounting		Flush
No. of faciawindows		12
Supplyvoltage		30 V DC
No. of LEDsperwindow		2
Letteringonfaciaplate		Properly engraved

**C. PANEL D.C. FAIL ALARM SCHEME**

Control & Relay Panel shall have a common — Panel D.C. Fail Alarm Scheme operated by 230V Single phase A.C. Aux. Supply for audible as well as visual alarm in case of failure of D.C. incoming supply to the Panel.

Another Single Element Relay without Flag and 1 no. self-reset type N/O & 1 no. N/C contact having inscription Panel D.C. fail alarm accept Relay shall be provided. Besides above, 1 no. Indicating Lamp, 1 no. A.C. Operated Electric Hooter and 2 nos. Push Button, one having 1 no. N/C contact, the other having 1 no. N/O contact shall also be provided for successful operation of the scheme. All auxiliary relays required to render Annunciation System operative and shall be considered to be within the scope of the tender.

AC fail, DC fail schemes shall be operated by relay not contactor.

**19.0 INDICATING INSTRUMENT AND METERS**

- a. All instruments shall be flush mounted, back connected type and provided with dust tight cases for tropical use with dull black enamel finish. All fixing screws, nuts and threaded parts shall be designed to Indian Standards.
- b. All instruments shall be of class 0.5 type. The calibration of the instruments shall function satisfactorily when mounted on steel panels or alternatively magnetically shielded instruments shall be used.
- c. Instruments shall be capable of indicating freely when operated continuously at any temperature from 0 to 50 degree C.
- d. All circuits of instruments shall be capable of withstanding applied load of 20% greater than the rated capacity for a period of eight hours.
- e. The instruments shall be capable of withstanding the effect of shock vibration and a dielectric test of 2000 Volts r.m.s. to ground for one minute as per relevant ISS.

**19.1 Ammeters:**

All ammeters shall be provided with direct readings scale. Full Scale Value of the Ammeters shall be 100% of the nominal current of maximum C.T. ratio. The ammeters shall be connected to measuring C.T. Core. Ammeters shall be suitable for R.Y.B. Phase measurements. However, the ammeter to be supplied shall be of type –DIGITAL|. The auxiliary power of the ammeters should be 230VAC.

19.2 Voltmeters

Volt Meters shall be provided with direct readings scale. The maximum value of the volt-scale be 15% in excess of the normal Circuit Voltage. The rated voltage of the Volt Meters shall be 110V A.C. However, the volt meter to be supplied shall be of type –DIGITAL|. The auxiliary power of the volt meters should be 230VAC.

a. Voltmeter Selector Switch:

One Voltmeter selector switch having 7 position 6 way stay-put type shall be provided.

b. PT Selector Switch:

One PT selector switch, 2 position, stay put type shall be provided.

19.3 Energy Meters

Tariff Metering Equipments

(a) Three element Tri-vector Meters shall be supplied by the EMPLOYER. But Panel Wiring for the Meters along with Test Terminal Block and space for the Tri-vector Meters are to be provided for the Panels.

20.0 NAME OF IDENTITY PLATES

a) All instruments, relays and such other similar electrical devices mounted on the control and relay panel shall be provided with name plates bearing the manufacturer's name, serial identifying number and the Electrical rating data.

b) 3mm thick and 25mm X 150mm brass or plastic plates bearing suitable identification marks shall be fixed under the terminal wiring at the test blocks, at the fuse blocks and at the cable terminals. Similar plates shall be fixed on the exterior of the panel in appropriate place to indicate function of control switches, push button etc. such as isolator control switch, breaker control switch, DC fail test, accept reset etc. Suitable identification marks shall be provided for individual casing part of the relays and other equipment. Plates should be screwed and riveted to the Panel.

c) 50mm wide brass or plastic plate bearing suitable circuit description (which will be furnished after order is placed) etched in 30 mms size letters shall be provided for each panel and mounted on the top of both outer of the front panels. These plates shall be removable type.

d) Schematic Diagram of CT, PT, CB circuitry & AC, DC Ckt, Indication and Annunciation Ckt along with protection circuitry giving the terminal nos. and Buswire details shall be printed in laminated durable stickers and pasted inside the panel Door page wise of the respective panel.

e) Each unit of control and relay panel shall be provided with a label located at the bottom on the front and shall contain the following details:



- i) Manufacturer's name
- ii) P.O.no. and date
- iii) Drg.ref.no. pertaining to the panel.

21.0 PAINTING

Panel painting shall be done by the modern process of painting. All unfurnished surface of the steel panel and framework shall be sand blasted or suitably cured to remove rust, scale, foreign adhering matter or grease. As suitable rust resisting primers shall be applied on the interior and exterior surface of steel, which shall be followed by application of an undercoat suitable to serve as base and binder for the finishing coat.

Details of Painting:-

Surface treatment	by seven tank process
Paint type	Powder coated. Pure polyester base grade A structure finish
Paint shade	RAL 7032 for external & internal surface
Paint thickness	Minimum 80 microns

22.0 RELAYS:

A. GENERAL REQUIREMENT

The main protective relays SCADA Compatible Numerical Directional/Non Directional O/C & E/F Relays shall be of panel manufacturer's own make. However, multinational company manufacturing panel in India may import required/desired relays from their foreign counterpart with same brand name at their own risk, cost and responsibility without hampering the stipulated delivery schedule as stated in the tender notification.

All numerical relays shall be provided with 'Relay Failure Annunciation contact'.

B. SCADA COMPATIBLE NUMERICAL DIRECTIONAL/NON DIRECTIONAL O/C & E/F RELAYS

The primary requirements of the relays are to protect the respective single circuit or double circuit feeders and 33/11 KV Power Transformers in the event of fault. The Directional/Non Directional E/F relays shall provide suitable sensitivity for limited earth fault current.

The relays should be suitable for substation automation, primary circuit breaker operation through SCADA from remote control room.

THE DETAILED SPECIFICATION OF Non-Directional O/C and E/F RELAY IS AS PER ANNEXURE-I OF SPECIFICATION

THE DETAILED SPECIFICATION OF Directional O/C and E/F RELAY IS AS PER ANNEXURE-II OF SPECIFICATION

C. OTHER PROTECTIVE RELAYS

- Differential relay shall be of numerical type
- REF relay etc. may be of static type.

**D. OTHER PARTICULARS RELATED TO ALL RELAYS**

- 1) All shall conform to the requirement of IS:3231/IEC255 and shall be suitable for operation within a temperature range 0°C to 55°C and 95% relative humidity. Relays shall be suitable for flush/semi flush mounting on the panel with connections from the rear, protected with dust tight cases for tropical use and with transparent cover removable from the front.
- 2) All A.C. relays shall be suitable for operation at 50 Hz. The current coils shall be rated for a continuous current of 1 amp and the voltage coil for 230 V normal. The contacts of the relays shall be properly designed to prevent or minimise damage due to arcs which have to be broken successfully against 30 V +/- 10% volt DC. When open, the contacts shall withstand a voltage of 115% of the normal circuit voltage. The relays shall be designed for satisfactory operation between 70% to 110% of rated D.C. voltage of the sub-station. The voltage operated relays shall have adequate thermal capacity for continuous operation.
- 3) Timers shall be of static type. Pneumatic timers are not acceptable.
- 4) The Relays shall preferably be provided with suitable Seal-in-Devices. Relays should be immune to all types of external influences like Electro static, Electromagnetic, Radio interference, shock etc.
- 5) All the numerical relays should have provision for setting all the features available in the relay and viewing those settings as well as different other parameters through both built-in display unit as well as through PC. All numerical relays shall have self monitoring feature with watchdog contact. The supply of relay should be inclusive of necessary software and hardware for interfacing with a PC, to be supplied by the manufacturer.

**E. PROTECTION SCHEMES**

**E-1 PROTECTION SCHEMES FOR 33 KV FEEDER**

**NON-DIRECTIONAL OVERCURRENT AND E/F PROTECTION:**

This relay shall be used for 33 KV radial feeder. The relay shall

- a) be three O/C & one E/F element type.
- b) have IDMT characteristics with time current characteristics of 3 sec at 10 times current setting.
- c) have variable current setting of 50% to 200% of rated current and adjustable time setting.
- d) have high set unit with current setting 500%-2000% for protection and 33 KV feeder protection, with very low transient overreach.
- e) Definite Time Sensitive Earth Fault Protection may be in built function of Numerical over-current Relay and shall have a variable current setting range minimum 1% to 40% in very small steps of CT secondary current and wide range of definite time setting range minimum 0.1 to 10 Sec. This relay shall be used in 33 KV feeder for detection of line to ground fault current of both very low and high magnitude where the 33 KV system is grounded through earthing transformer.
- f) LED indication for numerical relays of different type of faults including phase identification.

**E-2 PROTECTION SCHEMES FOR 33 KV PARALLEL FEEDERS AT RECEIVING ENDS**

**DIRECTIONAL PROTECTION**

Directional O/C & Directional Instantaneous E/F Relay shall be required for 33KV parallel feeders as specified in the schedule of requirement. Each Feeder shall be provided with 3 elements IDMT Voltage polarized O/C Relays and single element voltage polarized E/F Relay. The O/C Relay shall be IDMT type with high set element. The E/F Relay shall have directional sensitive E/F setting having wider range of setting (1-40%) & wider range of definite time setting range minimum 0.1 to 10 Sec. The relay shall also have instantaneous unit. The relay shall have necessary P.T. fuse failure monitoring scheme.

Characteristics:-

O/C Element: IDMT with High Set Unit	Current Settings & Operating time	IDMT-50-200%, 0-3sec, Inst.-500-2000% or 400-1600%
MTA	Selectable MTA for Directional Relay should cover 1 <sup>st</sup> quadrant in a non-effectively grounded system	
Polarized P.T. Voltage	110V A.C.	
E/F Element		
Current Setting	1-40% (minimum.) in very small steps	
Operating Time of Relay	Instantaneous	
Operating Time of Timer	0.1 to 10 Sec in very small steps	
MTA	Selectable MTA for Directional Relay should cover 1 <sup>st</sup> quadrant in a non-effectively grounded system	
Open Delta P.T. Voltage	63.5V A.C.	

The numerical directional relay shall have in-built feature for derivation of zero sequence voltage internally. If separate IVT is required for derivation of zero sequence voltage for directional earth fault element, the particular shall be as per following Technical Parameters:-

1	Insulation Level	1.1KV
2	Over Voltage Factor	1.2 Cont./1.9 for 8Hrs.
3	Transformation Ratio	110V/√3 / 110/√3
4	V Burden/Phase	7.5
5	Accuracy Class	3P
6	No. of Phase	Single
7	Type	Epoxy Cast Resin Indoor Single Phase Voltage Transformer
8	Formation	3 nos. Single Phase P.T. shall be connected in primary as Star and Secondary as Open Delta with neutral of Primary and one end of Open Delta earthed.

**E-3 PROTECTION OF 33KV INDIVIDUAL TRANSFORMERS**

For protection of H.V. Side of the Transformers, following main protective relays are required

- i) Numerical O/C protection.
- ii) 2 sets Restricted E/F Relays shall be provided for HV and LV side of individual control transformer panel.
- iii) 1 set Differential Relay in addition to above, shall be provided for 10MVA 33/11KV transformer panel.

Differential Relays shall be

- a) Provided at 33KV panel of the transformer to be protected. It shall be numerical adjustable/variable percentage biased type differential relay.  
  
Necessary software, cables, connectors and other accessories as required for download, analyzed data etc. shall be within the scope of successful manufacturer.
- b) The relay shall be very fast in operation with an operating time less than 40 milliseconds at 5 times setting.
- c) The relay shall be inherently stable for external through fault conditions without affecting the speed of operation for internal faults.
- d) The relay shall have either a built-in facility of ratio and phase angle correction or necessary interposing Auxiliary current transformers of universal type, shall be provided in the respective panel.
- e) The relay shall be provided with 2nd harmonic restraint or any other inrush proof feature to prevent operation due to magnetizing inrush current when the transformer is charged either from HV or LV side. But this shall not affect the speed of operation for internal fault.
- f) It shall be provided with 5th harmonic restraint features to prevent operation due to possible over excitation of the transformer. This shall also not affect the speed of operation for internal fault.
- g) The relay shall have adjustable bias setting range 20% to 50% and adjustable operating setting range of 10% to 50% at zero bias.
- h) It shall have three instantaneous high set over current units for clearing heavy internal fault.
- i) The relay shall be with 2-bias winding.
- j) The relay shall be such that there will not be any necessity of changing the setting of the relay whenever the transformer taps are changed from +5% to -10%.
- k) The manufacturer has to furnish the type test report from CPRI/NABL accredited Govt. recognized Test House and performance certificate from Power Utilities in India.
- l) Differential relay shall have facility for setting, parameterization, downloading the storage data, data captured by disturbance recorder etc. locally through PC. The necessary PC, Windows based Licensed software for establishing the facility to be considered in the scope of the supply by the Manufacturer.
- m) The relay shall have disturbance recording (with timestamping) function with suitable no. of analog and digital channels, Memory size and number of disturbances stored in the relay shall be clearly indicated in the offer. No. of sites selectable BI, BO and watchdog contact details, communication port details (front, rear) along with necessary hardware and software details shall be furnished.

**E-4 RESTRICTED EARTH FAULT PROTECTION**

The above protections shall be provided for 33/11KV transformers at HV and LV side. The Relays shall be:

- a) Single pole type.
- b) Current/voltage operated high impedance type with a suitable setting to cover the maximum portion of transformer winding. Necessary calculation to prove the above winding coverage shall be furnished along with the tender.
- c) Tuned to the system frequency.
- d) Have a suitable non-linear resistor to limit the peak voltage and stabilizing resistance.
- e) Operating time shall be less than 40 ms.
- f) Shall be a stand alone type.
- g) Have a suitable stabilizing resistor to prevent maloperation during external faults if necessary.

**E-5 A set of D.C. Voltage Operated Aux. Relays with coil cut-off arrangement and 4NO and 4NC contacts, hand reset with flag indicator type shall be provided for each Transformer for**

- (a) Buchholz Alarm
- (b) Buchholz Trip
- (c) Winding Temp. Trip & winding temp. alarm
- (d) Oil Temp trip & Oil Temp. Alarm
- (e) Low Oil Level Alarm
- (f) Pressure Release Device Trip
- (g) OSR for OLT Trip

Each Transformer Panel shall be provided with a High Speed Tripping Relay with coil cut-off arrangement having 6NO and 4NC electrical reset with flag indicator type.

**E-6 AUXILIARY RELAYS, TRIP RELAYS and TRIP COIL/CIRCUIT SUPERVISION RELAYS**

Auxiliary Relays- D.C. Voltage operated auxiliary relays provided with mechanically operated hand reset indicator and sufficient no. of hand reset contacts shall be provided for protection and supervision against transformer internal trouble/faults. No of elements and number of relays shall be as per requirement of individual transformer.

For Trip Circuit Supervision Relays - All Panels should be provided with D.C. Voltage operated Trip Circuit Supervision Relay having provisions for pre & post close supervision of Trip Circuit with set of self-reset contacts provided for Trip Circuit Healthy Indication and Trip Circuit unhealthy indication & Alarm in respect of Trip Coil/circuit of respective Breakers.

Tripping Relays- All Panels should be provided with D.C. Voltage operated High Speed Tripping Relays having self reset contacts capable to make, carry and break trip coil current. Set of Trip Contacts shall be provided for Inter-tripping function of corresponding 11 KV Incoming Switch gear and closing blocking function of 33KV & 11KV Breakers in respect of Transformer Control Panels. Each set of trip relay shall have minimum two nos. NO and 1 No. NC contact as SPARES. The operating time of master trip relay shall be less than 40ms and electrical reset type.

**E-7 TRIP CIRCUIT/COIL SUPERVISION SCHEME:**

Trip circuit supervision scheme shall be such that testing of trip circuit healthiness is possible irrespective of whether the C.B. is in the closed or open position. The Trip Circuit Healthy LED should glow continuously in CB ON Position and on demand in C.B. OFF position. The rating of dropping resistance in series with Trip Circuit Healthy LED shall be such that the Trip Coil should not get damaged because of continuous current flowing through it.

**E-8 Principal requirements of protective relays, metering equipments, auxiliary relays breaker**

controlswitchesetc.areasfollows:

**E-8-1 Ammeter:**

Eachcircuitoneammetershallbeprovidedwiththefollowing:

Mounting	Flush
Size	96 x96mm.case
ResponseTime	1second
OperatingTemperature	Upto55°C
DielectricStrength	2 kVRMSfor1minute
AuxiliarySupply	230volt A.C.,50Hz
OperatingCurrent	1AfromCTSecondary.
Type	PanelMountingwith3 <sup>1</sup> / <sub>2</sub> DigitalDisplay.

**E-8-2 VoltMeter:-**

Mounting	Flush
Size	96 x96mm.Case
ResponseTime	1second
OperatingTemperature	Upto55°C
DielectricStrength	2 kVRMSfor1minute
AuxiliarySupply	230V A.C.,50Hz
Frequency	50 Hz
OperatingVoltage	110VfromPTSecondary.
Type	PanelMountingwith3 <sup>1</sup> / <sub>2</sub> DigitalDisplay.

**E-8-3 Buzzer**

OneDCbuzzerhallbeprovidedinthepanelfor non-tripalarm.OneDCBellshallbe providedfor Tripalarmandone AC Bellfor PanelDCfailalarm.

**E-8-4 Highspeedtripping relayelectricallyresettabletype confirming toIS-3231**

Aux. voltage	30Vor 110VD.C tobedecided duringdetailed engineeringstage
Coil rating	30VD.C.,voltage band for satisfactoryoperation: 50to 120%ofrated voltage
OperatingTime	40m. seconds nominal atrated voltage
Burden of relay coil watts(Max)	Lowburden 40Watt atrated voltage
Operatingtemp	-10deg C to55deg C.
Operational indicationfor each element	Mechanicalredcolour Flag: ElectricalResetType
ContactConfiguration	6NO+4 NCcombinationwithadditionalhand resetcoil cutofcontact(Seal incontact)

**Contactratings:**

Makeandcarry	A.C. 1250VAwithmax5amp& 660Volts
--------------	----------------------------------

	D.C. 1250Wdcwithmax5amp& 660Volts
Make and carry for 3sec.	A.C. 7500VAwithmax30amp& 660Volts D.C. 7500Wdcwithmax 30amp& 660Volts
Break	A.C. 1250VAwithmax5amp& 660Volts D.C. –100Wresistive50 wattinductivewithmax 5 amp&660Volts
Insulation	2 KVRMS,50Hz for1min. 2.5KV/1secbetween all terminals&caseas perIS 3231. 1 KVRMS,50Hz for1min. acrossopen contact
Typeofmounting	Flush

E-8-5 Numericalbaseddifferentialprotectionrelaywithinbuiltcurrentamplitude& vectorgroup compensationfeature&alsowith differentialhigh setelementfortwo windingpowertransformercomplianttoIEC60255.

Aux. voltage	30Vor 110VD.C tobedecided duringdetailed engineeringstage
C.T. secondary	Selectable1amps/ 5ampsfor both HV&LV sides
Onlinedisplayof HV& LV phasecurrents &differentialcurrent	
Adjustablebias setting	10to 50%In.
Operationbasedonfundamentalfrequency	
Programmable HV/LVCTratio ofT/F vector group	
InbuiltREF protection	
InbuiltHV & LVsideovercurrent&earth faultprotection	
Inbuilttransformertroubleauxiliaryrelay	
BacklitLCDdisplay	
Harmonicrestrainfeature	
Storingfacilityof latest5fault eventswith real timeclock	
Passwordprotection	
DC burden	Quiescent condition–approx4watt Undertripcondition–30Volt- approx4watt,110Volt- approx7 watt.
AC burden	Throughcurrentonly–approx0.15VA for1amp&0.30VA for5amp(per bias circuit) Bias &differentialCktonly:2.8VAfor1amp&3.2VAfor5 amp.
Contactarrangements	Twochangeoverself resettrippingcontacts&two annunciationcontacts
Contact rating	Make&carry7500VAfor 0.2sec.withmax30A & 300 V AC or DC carry continuously 5 amp AC or DC break 1250 VA AC or 50 W DC resistive, 25 W L/R – 0.04ssubjectto max. 5amp&300Volts
Current Input	Sixfor differential&onefor REF
Self diagnosis featureforhealthinessof relay	

Flush mounted /drawout type

23.0 Guarantee:-

The panels shall be delivered to the various consignees of the EMPLOYER and shall be suitably packed to avoid damages during transit.

The C&R Panel with relays with all integral parts of the Equipment will be guaranteed for the period of five years from the date of last dispatch.

In the event of any defect in the Equipment, relay, any integral part of the Equipment arising out of faulty design, materials, workmanship within the above period, the suppliers shall guarantee to replace or repair to the satisfaction of EMPLOYER.

If the supplier fails to do so, within one month of receipt of intimation, EMPLOYER reserves the right to effect repair or replacement by any other agency and recover charges for repair or replacement from the supplier.

24.0 TESTS: -

24.1 Type Test: -

24.1.1 The Manufacturer should submit the Type test report including functional test for all the protective relays and C&R panels carried out within five years from the due date of submission of tender from CPRI/NABL accredited Laboratory/ Govt. Recognized test house or Laboratory on the tendered items as per relevant Standard & Tender Specification with the purchase order failing which the lot shall be rejected. The Type tests for Numerical Relays are to be submitted as specified in Annexure-I & II of Relays specification.

24.1.2 Test at Factory:

The following Tests shall be carried out. 6 copies of Test certificates shall be submitted for approval. The Equipment shall only be dispatched after approval of the test certificates.

1. Checking of wiring of circuits and the continuity.
2. One minute applied voltage test. All Equipment on panel and small wirings shall be tested for withstand voltage of 2000 Volt to earth & between different voltage circuits.
3. Insulation resistance of the complete wiring, circuit by circuit with all equipments mounted on the Board before and after H.V. test mentioned under 2 above.
4. Routine tests according to relevant National Standard are on the Instruments, relays & other devices.

25.0 INSPECTION:

25.1 Acceptance test at manufacturer's works in presence of purchaser's representative shall be carried out. The suppliers shall give at least 15 days notice of the date when the tests are to be carried out. Purchasers shall give the right to select any quantity of the item wise offered lot for testing, offered for inspection and in the event of failure in test(s), the purchaser shall have the right to reject the offered equipments.

25.2 All relays, meters & annunciators provided in the control & relay panels are to be accepted only after successful hundred percent performance testing at testing department of EMPLOYER.

25.3 The inspection may be carried out by the EMPLOYER at any stage of manufacturing. The successful Manufacturer shall grant free access to the EMPLOYER's representative/s at a reasonable notice when the work is in progress. Inspection and acceptance of any equipment under this specification by the EMPLOYER, shall not relieve the supplier of his obligation of furnishing equipment in accordance with the specification and shall not prevent subsequent rejection if the equipment is found to be defective.



25.4 The manufacturer shall keep the EMPLOYER informed in advance, about the manufacturing programmes so that an arrangement can be made from stage inspection.

25.5 The EMPLOYER reserves the right to insist for witnessing the acceptance/routine testing of the bought out items. The suppliers shall keep the EMPLOYER informed, in advance, about such testing programme.

26.0 SPARES:

The manufacturer shall quote item-wise Unit Prices for all type of relays and other consumable spares recommended by him. Such spare shall include Fuse Holders, Fuses, Indicating Lamps, essential spare parts of Relays, Instrument, extra Control Switches etc. EMPLOYER may procure these items from the successful manufacturer.

27.0 DRAWING & LITERATURE

Triplicate copies of the following drawings and literature shall be submitted along with the order copy:-

(a) Principal dimension details of each unit cubicles, complete assembly of panel and proposed arrangement of the Panel in a Control Room.

(b) Front and rear views of the Panel with instrument and device positions marked.

(c) Pictorial views of the Control Switches Terminal Blocks, Indication Instruments, Test Blocks, and exploded views of draw out type instructions and Fuse Blocks.

(d) Schematic Wing Diagram for Test Terminal Block.

(e) Illustrative, descriptive literature, General Technical Data & Specification of Devices.

f) make, type, particulars, literatures of each and every relay (protective & auxiliary), meters, annunciators, switches, lamps, TBS, TTBS etc. along with bill of material in line with specification.

28.0 CONTRACT DRAWINGS & LITERATURE

In the event of an order materializing, the Supplier also submit four prints of each drawing for approval of the EMPLOYER along with 2 sets of literature as mentioned in the spec.

The Contract drawings shall cover the followings:-

(a) Details of construction and dimension of a cubicle and of the complete Panel.

(b) Template for foundation and details of Cable Trench and Cable Entry Holes in the Foundation Platform.

(c) Elementary diagrams of all controls, metering, protection annunciation and other circuits. All devices shall be numbered according to ASA or international usage, which shall be separately coded.

(d) Cabling and wiring diagram of the cubicles and inter-connections between them. Ferrule numbers, device number and grouping for cable take off shall be distinctly shown.

(e) Dimensional outlined drilling diagram and special mounting arrangement if any, of such type of various devices on the Panel.

- (f) Inter-connection diagram between Control Panel and C.B. power and instrument transformer etc.
- (g) Wiring Schedule for Control & Relay Panel.
- (h) Internal wiring diagram of all devices and elementary wiring diagram of relays where internal wiring is in triplicate. Construction details of switches, terminal blocks and test block etc.
- (i) After approval, 10 set of the final contract drawing for each set of Control & Relay Panels are to be supplied by the Manufacturer. One set reproducible tracing of the above drawings in soft format shall also be supplied.

In the event of contract being awarded, 4 copies of the following literatures shall be supplied along with the drawings as mentioned:-

- (a) Literature describing construction, operation, adjustment and rating specifications of all the protective and auxiliary relays, recording instruments, metering instruments and control switches.
- (b) Literature giving rating data, details and adjustments for calibration of the indicating instruments.
- (c) Calibration instruments for the metering instruments.
- (d) List of spare parts, identification number of renewable parts of relays, instruments and switches etc. with the help of which the EMPLOYER will be able to procure spare parts from the manufacturer at any subsequent time.
- (e) It is desired that the complete schematic drawing is provided on a permanently laminated/engraved plate of suitable thickness which has to be bolted/riveted at the four corners on the inside face of rear door. In addition, one more plate of similar type and dimension shall be provided on the outside of the rear door providing guidelines and instructions for operation. The guidelines and schematic to be provided on the plate shall be as per approved drawings.

**29.0 DOCUMENTS TO BE SUBMITTED ALONG WITH THE OFFER:**

The manufacturer shall invariably submit the following documents failing which the offers are liable for rejection:-

- 29.1 Bill of Material (schedule-IA/IB/IC).
- 29.2 Documents supporting the qualifying requirements/past performance reports schedule-III).
- 29.3 Undertakings from relay manufacturer regarding (Schedule-IV): -
  - 29.3.1 Non-phasing out of the relays for at least 10 years from the date of supply
  - 29.3.2 For extending technical support and back-up guarantee
- 29.4 Detailed catalogue/technical literature in respect of all components/accessories including bought-out items.
- 29.5 Names of supplier of bought-out item.
- 29.6 List of testing equipment available with the Manufacturer.

**30.0 QUALITY ASSURANCE PLAN**

- 30.1 The Manufacturer shall invariably furnish QA Pass specified in Annexure-III along with

his offer the QAP adopted by him in the process of manufacturing.

30.2 Precaution taken for ensuring usages of quality raw material and subcomponent shall be stated in QAP.

31.0 GUARANTEED TECHNICAL PARTICULARS:

Manufacturers shall furnish Guaranteed Technical Particulars of equipment offered mentioning thereon Make & Technical particulars of each device as per schedule specified. Performance Guarantee will be based on the Guaranteed Technical Particulars.

Schedule-II -- GTP for C&R Panel

Schedule-V -- GTP for Non Directional/Directional IO/C&E/F Relay

Schedule-VI -- GTP for Master Trip Relay

Schedule-VII -- GTP for Differential Protection Relay

The discrepancies, if any, between the specification and the catalogs and/or literatures submitted as part of the offer by the manufacturers, the same shall not be considered and representations in this regard will not be entertained.

32.0 Bus Configuration and Bill of material

32.1 33/11KV delta star individual control transformer panel having HV side control and protection. Single main bus with bus section isolator scheme.

2 nos.	Circuit label engraved suitably at front and inner side
1 no.	Section of painted and overlaid mimic diagram
1 no.	Circuit breaker control switch.
6 nos.	Indicating lamps for circuit breaker ON/OFF, spring charged, trip circuit 1&2 healthy and auto trip indication.
2 nos.	Trip circuit supervision relay to supervise the TC1&2 both under pre close and post close condition.
3 nos.	96mmx96mm meters scaled suitably.
1 no.	voltmeter of 96mmx96 mm
1 no.	Suitable space and wiring for non-tariff TVM for energy management.
1 set	Three phase 4 wire test terminal block for above.
1 no	Auxiliary relay with test push button for panel DC supervision relay.
16 way	Fascia window type annunciator complete with accept reset and test PB but without audible bell.

1 no	Triple pole, IDMTL, non-directional over current relay with setting range 50%-200% for IDMTL units and 500% - 2000% for high set unit.
2 nos	Restricted Earth Fault Relay current operated having setting range 10% to 40% both for HV & LV side of the Transformer.
1 no	High speed master tripping relay with contacts as required with lockout and coil supervision scheme complete.
1 set	Two bias Transformer differential relay (for 10 MVA only) with interposing auxiliary CTs (universal type) wherever necessary.
	PT selector switch, two position PT-1/PT-2 switch, stay put type (16A)
1 no.	Space heater with On/OFF switch and thermostat.
1 no.	Two element DC operated auxiliary relay having hand reset type contact with hand reset operating flag for transformer Buchholz trip and Buchholz alarm function. Each element with 4NO+2NCC contact.
1 no.	Two element DC operated auxiliary relay having hand reset type contact with hand reset operating flag for transformer winding temp. trip and alarm function. Each element with 4NO+2NCC contact.
1 no.	Two element DC operated auxiliary relay having hand reset type contact with hand reset operating flag for transformer Low Oil Level (Main Tank) and OSR (OLTC) alarm function. Each element with 4NO+2NCC contact.
1 no.	Two element DC operated auxiliary relay having hand reset type contact with hand reset operating flag for transformer Oil Temp. Trip and alarm function. Each element with 4NO+2NCC contact.
1 no.	Two element DC operated auxiliary relay having hand reset type contact with hand reset operating flag for transformer Maintank PRV trip and OLTC PRV Trip function. Each element with 4NO+2NCC contact.
1 no	Two element DC operated auxiliary relay having hand reset type contact with hand reset operating flag for OLTC Buchholz trip and spare. Each element with 4NO+2NCC contact.
1 no.	DC operated emergency lamp with switch.
1 no.	Cubicle illumination lamp operated from door switch.
1 no.	15A, 3 phase plug & socket with switch.
1 set	Panel accessories as necessary.
1 set	Other equipment, relay etc. as required to fulfill the scheme Requirement.
1 no	Local/Remote switch

32.2 33KV single feeder line C&R Panel with Nondirectional O/C&E/F protection and 33KV parallel feeder line C&R Panel with directional O/C&E/F protection. Single main bus with bus section isolator scheme.

2 no.	Circuit label engraved suitably at front and inner side
1 no.	Section of painted and overlaid mimic diagram

1 no.	Circuitbreakercontrolswitch.
6 nos.	Indicatinglampsforcircuitbreaker ON/OFF,spring charged,tripcircuit1&2healthy andautotripindication.
2 nos.	TripcircuitsupervisionrelaytosupervisetheTC1&2bothunderprecloseandpost closecondition.
3 nos.	ammeterof 96mmx96mmscaledsuitably.
1 no	Voltmeterof 96mmx96 mmscaledsuitably
1 no.	Suitablespaceandwiringfornon-tariffTVMforenergymanagement.
1 no.	Threephase4wiretestterminalblockforabove.
1 no.	Auxiliaryrelaywithtestpushbuttonfor panelDCsupervisionrelay.
12 way	FasciawindowtypeannunciatorcompletewithacceptresetandtestPBbutwithout audiblebell.
1 no	Triplepole,IDMTL,non-dir-overcurrentrelayas perclause23
1 no.	Single poledefinitetimesensitiveE/F relaycurrent operatedhavingwidesettingrange forsinglencircuitline.
1 no	Triplepole,IDMTL,directional overcurrent relaywithsetting range50%-200%for IDMTLunitsand instantaneous highsetunit-500%-2000%applicableforparallel linefeederas perschedule
1 no	Single pole directional definite time sensitive E/F relay currentoperated having widesettingrangeforsinglencircuitline. NECESSARY IPTs ARE WITHIN THE SCOPEOFMANUFACTURER
1 no.	Highspeedmastertrippingrelaywithcontactsasrequired withlockoutandcoil supervisionschemecomplete.
1 no.	PTselectorswitch,twopositionPT-1/PT-2switch,stayputtype(16A)
1 no.	SpaceheaterwithOn/OFFswitchandthermostat.
1 no.	DC operatedemergencylampwithswitch.
1 no.	Cubicleilluminationlampoperatedfromdoorswitch.
1 no.	15A,3 phaseplug &socketwithswitch.

1 set	Panel accessories as necessary.
1 no	Local/Remote switch
1 set	Other equipment, relay etc. as required to fulfill the scheme Requirement.

32.3 Common items: (where ever mentioned)

1 no.	96mmx96mm voltmeters scaled suitably.
3+3 nos.	PT supply indicating lamps, red-yellow-blue for each PT.
1 no	Voltmeter selector switch, 4-position, RY—YB—BR—OFF.
1 set	Audible bell and hooter for trip and non-trip fascia annunciation.
1 no	AC operated single element, auxiliary relay having only self reset contacts and with reverse flag for incoming AC supply supervision with test push button.
1 no	DC operated, two element, auxiliary relay having only self reset contact and with reverse flag for incoming DC and alarm bus DC fail supervision.
2 nos.	Test push button for above.
1 no	Single element AC operated auxiliary relay having self reset contact only for incoming DC and alarm bus DC fail alarm cancellation.
1 no	Push button for incoming DC and alarm bus DC fail alarm accept.
1 no	Indicating lamp for incoming DC and Alarm bus DC fail indication.
1 no	AC operated buzzer for incoming DC and Alarm bus DC fail audible alarm.

**Annexure-IV**

**Standard Make of Relay and Fittings**

1.	<b>Relays</b>	<b>Schneider,ABB,Siemens,Alstom</b>
2.	<b>Breaker Control Switch/Local- Remote switch</b>	<b>Kaycee/Recom/Switron</b>
3.	<b>Ammeter/Voltmeter Selector switch</b>	<b>Kaycee/Recom</b>
4.	<b>Static Ammeter/voltmeter</b>	<b>AE/RISHAV/Secure</b>
5.	<b>Push Buttons</b>	<b>Vaishno/Teknic/Lumen/STS</b>
6.	<b>Indicating Lamp with lens</b>	<b>Vaishno/Teknic/Lumen/STS</b>
7.	<b>Panel wiring</b>	<b>Finolex/Havvels/KEI/R. R.kables</b>
8.	<b>Hooter/Buzzer/Bell</b>	<b>Vaishno/STS/JVS/Bharani</b>
9.	<b>Annunciator</b>	<b>MINILEC/ALAN/INSTALARM/EAPL</b>

**Annexure-V**

**Legend of Devices associated with 33kVC&R Panel**

Symbol Reference	Description	Particulars
A1-A2-A3, Ah	Ammeter	As specified
V	Voltmeter	As specified
VS	Manual Voltmeter Selector Switch	As specified
EM	Tri-Vector Meter	As specified
CS	Control switch T-A/T-N-A/C-C spring return type	As specified
L/R	Local/Remote switch	As specified
IL-R	CB, "ON" Indication Red lamp	As specified
IL-G	CB, "OFF" Indication Green lamp	As specified
IL-W	"Trip /Close signal received from Remote Indication white lamp	As specified
IL-B	"Spring charged" Indication Blue lamp	As specified
IL-A	CB "Auto trip" Indication Amber lamp	As specified
PB	Push Button	As specified
ANN	DC operated electric Buzzer and Microprocessor based Electronic annunciator with built in watchdog and first fault indication facility. The annunciator shall have provision for trip and non trip alarm functions and Accept/Test/Reset/Mute Push buttons	As specified
H, HS, TH	Heater, Heater Switch, Thermostat	As specified
FS	Fuse	As specified
LK	Link	As specified
MCB1	MCB 2 pole 32 A for DC supply	As specified
MCB2	MCB 2 pole 16 A for AC supply	As specified
MCB3	MCB 2 pole for spring charging motor supply	As specified
MVS	Manual PT selector switch	As specified



IR-I	Remote intertripping contact from 33kV Transformer Control and relay Panel	As specified
TC	Tripping Coil	As specified
CC	Closing Coil	As specified
86	Tripping Relay for Tripping function	As specified
52	Vacuum Circuit breaker	As specified
52a, 52b	NO and NC contacts of Breaker Auxiliary switch respectively	As specified
PT	Potential Transformer	As specified
CT	Current Transformer	As specified
TTB	Test Terminal Block	As specified
51/50 R-Y-B-N	O/C and E/F protection	As specified
67 R-Y-B-N	Directional O/C and E/F protection	As specified
64	Restricted Earth Fault Protection	As specified
87	Differential Protection	As specified

SCHEDULE-IA

(To besubmitted,dulyfilledin,alongwiththeoffer) Billofmaterialsfor33KVfeederC&Rpanels

Sr. No	Description	Quantity	Make, Type&design
1	Circuitlabel	1 No.	
2	Mimic section(Brilliant green paint to shade No.221ofIS5tobeused)	1 No.	
3	T-N-Ctypecontrolswitchforcircuitbreaker.	1 No.	
4	IndicatingLEDsfor Springchargeindication(Blue) Tripcircuithealthyindication(white)oneeachfor Tripckt1 andTripCkt2 Breaker'ON'indication(Red) Breaker'OFF'indication(Green)	1 No. 2 Nos. 1 No. 1 No.	
5	Pushbuttonfor Tripcircuittest AlarmAccept/Reset/Test/Mute	1 No. 4 Nos.	
6	Numericalnon-directional IDMTovercurrentand earthfaultrelaywithhighsetinstantaneous trip feature	1 No.	
7	High speed Master tripping relay (Electrically resettable)	1 No.	
8	12 window annunciation scheme with accept, resetandLEDtestpushbuttonwithselfresetting audiblealarm.	1Set	
9	Ammeter(96mmx96mm.)	3Nos.	
10	Voltmeter(96mmx96mm.)&selectorswitch.	1Set	
11	Local/ Remoteswitch	1Set	
Internallymounted			
1	Spaceheaterandcontrolswitch	1Set	

2	Cubical illumination lamp and door switch	1 Set	
3	Power Plug, socket and control switch	1 set	
4	Alarm bell for trip	1 No.	
5	Alarm cancellation relay	1 No.	
6	Alarm buzzer for non trip with auto-stop feature (with variable time setting 0-60 seconds)	1 No.	
7	MCBs	As required	
8	Fuse and Links	As required	
9	Control wire	As required	

SCHEDULE-IB

Bill of materials for 33/11KV Transformer C&R panels with differential protection

Sr. No	Description	Quantity	Make , Type and design
1	Circuit label	1 No.	
2	Mimic section (Brilliant green paint to shade No. 221 of IS 5 to be used)	1 Set	
3	T-N-C type control switch for circuit breaker.	1 No.	
4	Indicating LEDs for		
	Spring charge indication (blue)	1 No.	
	Trip circuit healthy indication (white) one each for Trip ckt 1 and Trip Ckt 2	1 No.	
	Breaker 'ON' indication (Red)	1 No.	
	Breaker 'OFF' indication (Green)	1 No.	
5	Push button for Trip Circuit Healthy Test, Alarm accept/Reset/Test/Mute	5 NoS.	
6	Trip circuit Healthy test	1 No.	

7	Numerical non-directional IDMT overcurrent and earth fault relay with high set instantaneous trip feature	1 No.	
8	High speed master tripping relay (electrically resettable)	1 No.	
9	Space for HT Static TOD Tri-vector Energy meter and TTB.	1 No.	
10	Ammeter (96mm x 96mm.)	3 Nos. and 1 No.	
11	Voltmeter (96mm x 96mm.) & selector switch.	1 Sets	
12	Transformer differential numerical relay	1 No.	
13	16 window annunciation scheme with accept, reset and LED test push button with self resetting audible alarm.	1 No.	
14	Auxiliary relay for main tank Buchholz Alarm/trip (2-element)	1 Set	
15	Aux. relay for winding temp Alarm/trip (2-element)	1 Set	
16	Aux. relay for OLTC Buchholz Alarm/trip (2-element)	1 Set	
17	Aux. relay for low oil level alarm (Main Tank) & OSR (OLTC) Trip (2-element)	1 Set	
18	Aux. relay for oil temp alarm/trip (2-element)	1 Set	
19	Aux. relay for Main tank PRV & OLTC PRV Trip (2-element)	1 Set	
Internally mounted			
1	Space heater and control switch	1 No.	
2	Cubicle illumination lamp with door switch.	1 No.	
3	Power plug with control switch	1 No.	
4	MCB.	As required	
5	Fuse and Links	As required	
6	Control wire	As required	

SCHEDULE-IC

(To besubmitteddulyfilledinalongwiththeoffer)

Billofmaterialsfor33/11KVTransformerC&Rpanelswithoutdifferentialprotection.

Sr.	Description	Quantity	MakeandType desig
1	Circuitlabel	1 No.	
2	Mimicsection(Brilliant green painttoshadeNo.221 of IS5tobeused)	1 Set	
3	T-N-Ctypecontrolswitchforcircuitbreaker	1 No.	
4	IndicatingLEDsfor		
	Springchargeindication(blue)	1 No.	
	Tripcircuithealthyindication (white) oneeach forTrip Ckt1andTripCkt2	2 Nos.	
	Breaker'ON'indication(Red)	1 No.	
	Breaker'OFF'indication(Green)	1 No.	
5	PushbuttonforAnnunciationAC/RE/TEST/MUTS&TripCircuitHealthy	5 Nos	
6	Numerical non-directional IDMT over current and earthfaultrelaywithhighsetinstantaneousstrip feature.	1 No.	
7	Highspeedtrippingrelay (electricallyresettable)	1 No.	
8	Spacefor HT TODTri-vectorEnergymeterandTTB.	1 No.	
9	Ammeter(96mmx96mm.)	3 Nos. &1No	
10	Voltmeter(96mmx96mm.)&selectorswitch.	1 Set	
11	16 window annunciation scheme with accept, reset andLED testpush button withselfresetting audiblealarm.	1 No.	
12	Auxiliaryrelayfor maintankBuchholzAlarm/trip(2- element)	1 Set	

13	Aux.relayforwindingtempAlarm/trip(2-element)	1	Set	
14	Aux.relayforOLTCBuchholzAlarm/trip(2-element)	1	Set	
15	Aux. relay for low oil level alarm(Main tank) /OSR(OLTC)Trip(2-element)	1	Set	
16	Aux.relayfor oiltempalarm/trip(2-element)	1	Set	
17	Aux.relayforMaintankPRV/OLTCPRVtrip(2- element)	1	Set	
Internallymounted				
1	Spaceheaterandcontrolswitch	1 No.		
2	Cubicleilluminationlampwithdoorswitch.	1 No.		
3	Powerplugwithcontrolswitch	1 No.		
4	MCBs,fuses,links,controlwiring,etc.	Asrequired		
5	FuseandLinks	Asrequired		
6	Controlwire	Asrequired		

NOTE: THE MANUFACTURERS MUST HAVE TO SUBMIT SEPARATEBILL OF MATERIALFOR DIFFERENT TYPE OF PANELS WITH THE GUIDELINE AS MENTIONED ABOVE, FURNISHINGTHETYPEANDMAKEOFEACHITEM.

SCHEDULE- II

DETAILS OF RELAYS, METERS, EQUIPMENT & DEVICES AS OFFERED IN SCHEDULE OF 33  
 KVS IMPLICIT TYPE CONTROL AND RELAYS PANEL – TO BE FILLED UP BY THE MANUFACTURERS  
 ALONG WITH SUBMISSION OF SUPPORTING DOCUMENTS

Sl. No.	Description	Make And Country Of Manufacture	Type (Catalogue to be enclosed)	Brief Description, with CT/PT details, contact configuration, Input/Output details, characteristics, range, suitability etc. for clear perspective.
A	<b>SURFACE MOUNTING DEVICES</b>			
1	<b>Circuit Level</b>			
2	<b>Mimic Diagram</b>			
3	<b>Circuit Breaker Control Switch Spring return lost motion type</b>			
4	<b>Ammeter 96 mm sq. for C.T. Secondary rated Current 1A Scale 0-100/0-200A Scale 0-200A/0-400A</b>			
5	<b>Voltmeter 96 mm Sq. for P.T. Secondary 110VAC (L/L) Scale 0-40 KV</b>			
6	<b>Voltmeter Selector Switch 6 way &amp; off position having break before make contact</b>			
7	<b>Test Terminal block suitable for 3 phase 4 wire system with wire rear connecting stud having provision of sealing arrangement</b>			
8	<b>Multi way micro processor based Electronic Annunciator with building-system watchdog first fault indications and red &amp; yellow coloured windows with inscription for Trip &amp; Non Trip Alarm functions</b>			
9	<b>Indicating Lamps led type 63.5VAC for P.T. Supply indication with RED/YELLOW/BLUE Colours</b>			

10	<b>IndicatingLampLEDtype230VAC for Panel D.C. Fail Common Indication</b>			
11	<b>IndicatingLamp LED type30VDCfor CB ON/OFF AutoupSpringCharge TripCircuitHealthy Indication with RED/GREEN/ AMBER/BLUE Colours</b>			
12	<b>PushButton forPanelDCfailtest</b>			
13	<b>PushButton forincluding ACfailtest</b>			
14	<b>PushButton for nontripPanelDC failAlarmAccept</b>			
15	<b>PushButtonforAnnunciatorAlarm Test/Mute/Accept/Reset</b>			
16	<b>3 Element normal IDMTL over current Relay with instantaneous highsetunit</b>			
17	<b>Single Element Instantaneous sensitive Earth Fault Relay with Timer</b>			
18	<b>Triple Pole Directional Voltage polarized OverCurrent Relaywith Directional High SetUniton all Element</b>			
19	<b>Single Pole Directional Voltage polarized Instantaneous sensitive E/F Relaywithtimer</b>			
20	<b>HibalanceInstantaneousRestricted EarthFaultCirculatoryCurrentFault Relay  (a) HVside ofPower Trf. (b) LVside ofPower Trf.</b>			



21	<b>SingleElementHighSpeedTripping RelaywithelectricallyresetContact &amp;H/Rflag/indicationwithrequired numbersof contracts</b>			
22	<b>Two Element 30 V DC Voltage Actuated AuxiliaryRelay withHR Contacts&amp;HR/LEDFlag/indication forTransformerInternal Trouble functions</b>			
23	<b>Single Element 30V DC Voltage ActuatedAuxiliaryRelay with self ResetContact&amp;ReverseFlag indicationforPanel DC Supplyfail function</b>			
24	<b>Single Element 230V AC Voltage ActuatedAuxiliaryRelay with self ResetContacts&amp;Reverse Flag indication for incoming AC Supply failfunction</b>			
25	<b>30VDCVoltageoperatedRelayfor TripCircuitsupervisionpurposewith self resetcontact</b>			
26	<b>Single Element 230V AC Voltage ActuatedAuxiliaryRelay with self Reset Contacts without Flag indication for panel DC fail Alarm, Accept</b>			
27	<b>Additional Involvement of Single Element 30V DC Voltage Actuated Auxiliary Relay</b>			
28	<b>ExtraInvolvementofAuxiliaryRelay fornothavingsufficientcontactsto achieve requiredfunctions</b>			
29	<b>Space &amp;wiring for housing purchaser's projection mounting type Energy meter(notwithinth scope ofmanufacturer</b>			
30	<b>Common Electronic DC bell/Buzzer Trip&amp;Non-TripAlarmfunctions</b>			
31	<b>CommonElectronicACBallforPanel DC failAlarmfunctions</b>			

32	<b>Biased differential relay for 10MVA Trf. Control &amp; Relay Panel</b>			
B	<b>Inside Mounting Devices</b>			
1	<b>230V AC Cubicle illuminating lamp with door operated Switch/Toggle Switch</b>			
2	<b>30V DC Emergency Lamp with Toggle Switch</b>			
3	<b>230C AC 60W space heater with thermostat &amp; Toggle Switch</b>			
4	<b>15A Double VAC Combined 2/3 pin plug and socket with Switch</b>			
5	<b>15A Double Pole MCB for Incoming AC Supply</b>			
6	<b>Fuse</b>			
7	<b>Links</b>			
8	<b>Terminals</b>			
9	<b>Earthing Arrangement</b>			
10	<b>Interposing P.T. for Directional Relay if required</b>			
11	<b>Interposing Universal type CT for Differential Relay if required</b>			

**Note:**  
**All surface mounting devices excepting Energy meter, TT & Bells are flush mounting type as per Schedule requirement.**

**Schedule-V**

**GTPfor NumericalFeeder ProtectionRelay**

Sl. No.	FeatureandFunction	Supplier'sdetails
1.1	Make,Type,ModelNoandVersionNo andOrderingCode	
1.2	Conformanceto i.IEC255-4	
	ii. IEC 61850	
1.3	No. of CT inputs for O/C and E/F Protection	
1.4	Typetestreportssubmitted(y/n)	
1.5	Relayshall beof Numeric Design	
1.6	Relay designed for bay protection and Control	
1.7	Size of RelayLCDscreen	
1.8	Relayisequipped with CBcloseandopen key/push buttons	
1.9	Relayhas followingprotectionfunctions: a. Threephaseovercurrent b. Earth fault c. Thermaloverloadfunction d. Broken conductorprotectionfunction e. CircuitBreakerMaintenancefunction	

2.	<p>a. One time delayed element and two high set elements</p> <p>b. Setting range and step for IDMT element for both current and Time Multiplier Setting</p>	
	c. Selectable Current/Time Curve for IDMT element	
	d. Setting range and step for high set elements for both current and time delay	
10.	Sampling rate and frequency of analog signal	
11.	Whether remote controllable from SCADA	
12.	<p>a. No. of Digital Inputs</p> <p>b. Voltage rating of Digital Inputs</p> <p>c. Provision of testing without current injection</p>	
13.	Supervision for CB open and Closed status	
14.	No. of programmable LEDs and no. of Latched LEDs	
15.	Analog Measurement and display supported	
16.	Fault Record storage capacity	
17.	Event storage capacity	
18.	Disturbance record storage capacity	
19.	MMI with keypad and LCD provided	

20.	RatedDC Supplyandtolerance	
21.	RatingofCT/PTsecondary	
22.	Ratedfrequency	
23.	a.Operating ambient temperature & humidity	
	b. Withstanding capability of Electromagnetic Interference as per relevantpartof IEC 61850	
24.	Mounting	
25.	Watchdog	
26.	a. NominalFeeder current	
	b. CTRatiosetting	
	c.Earthfaultcurrent withtimedelayIEC Curves, 2 <sup>nd</sup> stage for instantaneous trip(lessthan 50ms)	
	d. Highsetwith delay	
	e.IECCurvesforallO/CandE/Fhaveuser selectable?	
27.	a. No. of Digital OutputContacts	
	b. Contactrating	

28.	ModeofTimeSynchronization	
29.	TypeofLugs andterminators	
30.	MTBF	
31.	Lifespan	
32.	CompliancetoTypeTest	
33.	CommunicationPort a. Rear port-details b. Frontport-details	
34.	Whether Communication Ports are nativetotheRelay	
35.	ProtocolsupportedforRear Port	
36.	ProtocolsupportedforFrontport	
37.	Startandtripoutputcontactsarefreely programmable	
38.	Cable for connection of Relay to laptop(USB port) along with converter and power supplyif required for relay local setting	

39.	Basic application software for setting change,parameterisation	
40.	CDwithsoftware(licensed)todownload disturbance recorder, event log and evaluationof thoserecords	
41.	GraphicalconfigurationtoolforI/P,O/P and functional building block for protectionandcontrol	
	Any other software required for integrationwith SCADA.	

-----

**Schedule-VI**

**GTP for Master Trip Relay**

<b>Sl.No.</b>	<b>Description</b>	<b>Manufacturer's Response</b>
<b>01.</b>	<b>Manufacturer Name</b>	
<b>02.</b>	<b>Typeanddesignation</b>	
<b>03.</b>	<b>Electricalreset</b>	
<b>04.</b>	<b>Mounting</b>	
<b>04.</b>	<b>HighBurdenrelay</b>	
<b>05.</b>	<b>OperatingTime</b>	
<b>06.</b>	<b>Rated DC supply and tolerance</b>	
<b>07.</b>	<b>No.ofNO Contact</b>	
<b>08.</b>	<b>No.ofNCContact</b>	

-----



**Schedule-VII**

GTP for Numerical Based Differential Relay

<b>Description</b>	<b>Manufacturer's Response</b>
<b>Manufacturer Name</b>	
<b>Type and designation</b>	
<b>Rated DC supply and tolerance</b>	
C.T. secondary current	
Adjustable bias setting	
Operation philosophy	
Whether Programmable HV/LV CT ratio of T/F vector group provided	
Inbuilt REF protection provided	
Inbuilt HV & LV side over current & earth fault protection provided	
Inbuilt transformer trouble auxiliary relay provided	
Display Type and details	
Whether Harmonic restrain feature available	
Details of Event Recording and storing facility	
Password protection	
DC burden	
AC burden	
Contact arrangements	
Contact rating	
Current Input	
Self diagnosis feature provided	
Mounting Arrangement	
Communication port Details	

**ANNEXURE-I**

**Technical specification for IEC 61850 compliant non-Directional O/C and E/F Relay with Bay control features**

Sl. No.	Feature and Function	Technical requirement
1	Purpose and application	<p>It is intended to automate the Switch gear as specified in the scope of supply and use Communicable Numeric relays for Protection, Control, Metering and Status monitoring. This specification is based on the understanding that an integrated Automation System along with protections shall be provided and same shall have provisions for Integration with SCADA system. All the feeders shall be remote controlled from EMPLOYER's SCADA and from the local console of the numerical relays.</p> <p>Numerical multifunctional combined Microprocessor based Feeder protection and management relay to protect the 33kV Feeder from all electrical and other faults along with reporting system, Disturbance record for fault analysis. Manufacturers should comply with any special requirement or feature asked for retrofitting the relays. Relays should be IEC 61850 compliant. Relays should have 4CT input for O/C and E/F protection. There should be option for derivation of E/F internally.</p>
2.	Main Protection Feature	<ol style="list-style-type: none"> <li>1. Relay should have minimum two group of setting. Setting group change over required from digital status input.</li> <li>2. Electrical overload protection with selectable IEC curves with two stage, first stage to be used as Definite Time /IDMT and second stage to be used as high set for short circuit protection.</li> <li>3. Earth fault protection in two stages with IEC characteristics. First stage to be used as IDMT/Definite Time and second stage to be used as instantaneous elements. Earth fault elements should be suitable for both CBCT and residual type CT connection.</li> <li>4. Negative phase sequence Protection with IEC Curves.</li> <li>5. CB Fail Protection &amp; time settable as per user.</li> <li>6. The relay should be immune to DC switching while carrying current. i.e. no spurious trip should be generated if relay DC is made On and Off</li> <li>7. The relay should conform to the IEC 255-4 or BS 142 for Inverse time characteristics.</li> <li>8. The relay should have features to monitor for broken conductor and CB opening time</li> </ol>
3.	Processor feature	<p>Relay shall be completely Numerical with protective elements having software algorithm based on sampling of Analog inputs. Sampling Rate of Analog Signal: The sampling rate should be 1.000 Hz for 50 Hz signal or</p>

4.	Operational Philosophy	<p>The operation of Relay shall be possible both locally from the Switchgear and remote &amp; Local Workstation. The local position shall be displayed in remote/local workstation and remote operations shall be blocked if the switch is in Local. Clear control priorities shall prevent initiation of operation of a single switch at the same time from more than one of the various control levels and there shall be interlocks among various control levels. The priority shall always be with the lowest enabled control level. Relay accuracy shall not be affected by system frequency fluctuation.</p>
5.	Status/Optical Inputs/Digital inputs	<ol style="list-style-type: none"> <li>1. Minimum 7 number status inputs are required</li> <li>2. All status inputs should be 30V DC/110V DC (will be mentioned during detailed Engineering as per requirement).</li> <li>3. Setting group is required to be changed with any Digital input status.</li> <li>4. Trip circuit supervision with DI status</li> <li>5. The digital inputs shall be acquired by exception with 1ms resolution. Contact bouncing in digital inputs shall not be assumed as change of state.</li> <li>6. Relay should have comprehensive self diagnostic feature with remote indication of relay failure and alarm shall be generated without tripping of circuit</li> <li>7. Provision of Testing output relays without any current injection.</li> <li>8. No. of programmable LEDs - at least 4 nos. with latching option.</li> </ol>
6.	Main measuring and reporting feature	<p>All measurements should be in primary quantities. Minimum following displays are required in alpha numeric:-</p> <ol style="list-style-type: none"> <li>1. Three phase (Positive sequence) current</li> <li>2. Neutral (zero sequence) current</li> <li>3. All the trips should have clear indication on the relay terminals</li> <li>4. Resetting should be selectable as hand reset or auto reset.</li> <li>5. The default relay LCD shall be user defined to display primary circuit loading.</li> </ol>
7.	Memory and Recording Feature	<ol style="list-style-type: none"> <li>1. The relay setting and programming should be stored in EEPROM so that during Aux. Power failure the said data is not lost.</li> <li>2. Relay should have event log, trip log and DR record. All logs should go to history.</li> <li>3. All tripping of relay should initiate DR in auto without extraneous input. Triggering of DR with binary input should be user configurable.</li> </ol>

		<ol style="list-style-type: none"> <li>4. The last 2 fault DR records should be in flash memory and DR will not erase in case of DC supply fail for more than 2 days.</li> <li>5. Should be able to record at least 5 Oscillographic disturbances and 5 fault records and 250 event records.</li> <li>6. Minimum Four no. of latest trip log with cause of trip should be stored in memory along with date and time stamping. The memory should not be lost with the switching off of DC.</li> <li>7. The relay should have fault-recording feature with current waveform and Digital Input status. The fault waveform should consist of minimum four current waveforms of three phase current and zero sequence current and DI status. Triggering time for Pre and Post should have user selectable. This record should be in flash memory for minimum 7 (seven) days even after switching off the DC supply.</li> <li>8. The fault should be date and time stamped.</li> <li>9. Communication protocol IEC 61850.</li> </ol>
<b>8.</b>	Auxiliary Supply	30V or 110VDC (will be mentioned during detailed Engineering as per requirement) to -25% to +10%, 2 wire unearthened system. Necessary software shall be in-built for proper shutdown and restart in case of power failure. Auxiliary supply burden will be around 20Watt.
<b>9.</b>	Rated CT/PT secondary	5/1Amp (User selectable), CT used to be protection class
<b>10.</b>	Rated frequency	50HZ +/- 5%
<b>11.</b>	Ambient condition	<ol style="list-style-type: none"> <li>1. Operating ambient temperature up to 55 Deg C</li> <li>2. Operating Humidity up to 100%</li> <li>3. Relay shall meet the requirement for withstanding electromagnetic interference according to relevant parts of IEC 61850. Failure of single component within the equipment shall neither cause unwanted operation nor lead to a complete system breakdown.</li> </ol>
<b>12.</b>	Module and Mounting	<ol style="list-style-type: none"> <li>1. Relay should be flush mounted type</li> <li>2. If module is draw out type then it should have CT shorting facility of make before break type.</li> <li>3. Mounting in switch gears located in non AC rooms.</li> <li>4. Galvanic isolation between field connection and relay hardware should be there.</li> </ol>
<b>13.</b>	Watchdog and self monitoring	The relay should have facility to monitor the healthiness of its circuits and components by own monitoring system. In case of any problems, the alarm should be generated by one of the output contacts. The alarm as soft signal to be sent to SCADA system as well. Necessary support

		documentation explaining these self diagnostic features shall be furnished with dog contacts shall be provided in addition to required 7BI and 7BO.
<b>14.</b>	Settings	<p>Approximate settings possible should be as follows:-</p> <ol style="list-style-type: none"> <li>1. Nominal Feeder current 2% to 110%</li> <li>2. CT Ratio setting 10-1000 (approx.)</li> <li>3. Earth fault current 5 to 40% with time delay IEC Curves, 2<sup>nd</sup> stage for instantaneous trip (less than 50 ms)</li> <li>4. Overcurrent trip - 50% to 200% of 1/5 Amp with time delay as per IEC Curves.</li> <li>5. High set with delay 200% to 2000%</li> <li>6. IEC Curves for all O/C and E/F have user selectable.</li> </ol>
<b>15.</b>	Output Relays	<p>Minimum 7 number output relays are required out of which</p> <ol style="list-style-type: none"> <li>1. One potential free change over contact should be provided for start inhibit of relay.</li> <li>2. All o/p contacts should be freely programmable.</li> <li>3. Rating of trip contacts:- <ol style="list-style-type: none"> <li>a) Contact durability &gt; 10K operation</li> <li>b) 15 Amp make and carry for 3 sec for trip contact</li> </ol>                     Make and carry for trip contacts L/R &lt;= 40ms Rating of Alarm contacts:- <ol style="list-style-type: none"> <li>a) 8 Amp make and carry continuously for 5 sec.</li> </ol> </li> </ol> <p>Testing of Output relays through keypad on relay fascia and relay HMI software. Output relay dwell time shall be user programmable or fixed at 100ms.</p>
<b>16.</b>	Relay software and Man Machine Interface	<ol style="list-style-type: none"> <li>1. The relay should have native IEC 61850 Communication Protocol.</li> <li>2. Should have password protected keypad lock.</li> <li>3. Necessary software for relay setting, retrieving DR, event log, trip log should be supplied by the Manufacturer. Necessary License is to be issued for EMPLOYER, if required.</li> <li>4. Manufacturer has to supply communication hardware for relay setting, DR downloading from front port. This device should be compatible to USB/Ethernet port.</li> <li>5. It shall be possible to transfer the data stored in the DFR to computer on IEEE/COMTRADE format. The data format shall be compatible for dynamic protection relay testing on relay test kit. COMTRADE data viewing software to be provided.</li> <li>6. Multi user/Corporate license for installation on minimum 7 nos. of PCs.</li> </ol>

<b>17.</b>	Date and time	Date and Time stamping with faults and record. The clock should be powered from internal cell and should not require setting after every DC switching. The internal cell life minimum 5 years. Time synchronization by IRIG-B or SNTP. For time synchronization through SNTP it should be provided from clock signal coming from RTU. In case of IRIG-B, time synchronization will be done with GPS clock signal from GPS receiver located at substation.
<b>18.</b>	Lugs and terminators	All CT and PT terminals shall be provided as fixed (screwed) type terminals on the relay to avoid any hazard due to loose connection leading to CT opening or any other loose connection. Necessary amount of lugs should be supplied along with each relay for CT connection and control wiring.
<b>19.</b>	Manuals, Drawings and Literature	<ol style="list-style-type: none"> <li>1. The relay should be supplied with manuals with all technical and operating instructions.</li> <li>2. All the internal drawings indicating the logic and block diagram details explaining principle of operations should be given at the</li> </ol>
<b>20.</b>	Standard documentation per Relay, according to IEC 61850	<ol style="list-style-type: none"> <li>1. MICS document (model implementation conformance statement)</li> <li>2. PICS (protocol implementation conformance statement)</li> <li>3. Conformance Test certificate from KEMA/CPRI.</li> <li>4. PIXIT document</li> </ol> <p>All the above mentioned certificates shall be submitted.</p> <ol style="list-style-type: none"> <li>5. ICD file</li> <li>6. SCD file</li> </ol>
<b>21.</b>	Extendibility in Future	The Manufacturer shall provide all necessary software tools along with source code to perform addition of bays in future and complete integration with SCADA by the User. These software tools shall be able to configure relay, add analog variable, alarm list, event list, modify interlocking logic etc. for additional bays/equipments which shall be added in future.
<b>22.</b>	Lifespan	<p>The suppliers should mention following:-</p> <ol style="list-style-type: none"> <li>1. Product maturity: The Manufacturer should mention the time period for which the product is in the market</li> <li>2. Expected production life</li> <li>3. Hardware/Firmware change notification process. Upgrade should be provided free of cost within the Guarantee period/5 years whichever is later, if needed.</li> <li>4. Lifespan of standard tools and processes for relay configuration, querying</li> </ol>

<b>23.</b>	Standards	<p>The relays should conform to the IEC 255-5 or equivalent BS/ANSI for following:-</p> <ol style="list-style-type: none"> <li>1. Overload withstand test</li> <li>2. Dielectric withstand: 2kV in common, 1kV in differential mode</li> <li>3. Impulse Voltage: 5kV in common, 1kV in differential mode</li> <li>4. Insulation resistance &gt; 100M-ohm.</li> <li>5. Vibration: Shock and bump and Seismic</li> <li>6. Storing and transportation</li> <li>7. Radio Interference: IEC 61000 for high frequency disturbance, Transient disturbance, Electrostatic discharge</li> <li>8. KEMA Certification for the particular model offered with respect to IEC 61850 Protocol.</li> </ol>
<b>24.</b>	Communication Port	<ol style="list-style-type: none"> <li>1. Two nos. IEC 61850 protocol compliant Ethernet RJ45/F.O port for communication with SCADA system through two managed Ethernet Switches operating in redundant mode. The communication shall be made in 1+1 mode between individual IED to Switch, such that failure of one set of LAN shall not affect the normal operation of SCADA. However, it shall be alarmed in SCADA.</li> <li>2. Functioning of Relays shall not hamper to fault occurring any interconnected relay.</li> <li>3. One Front port Ethernet RJ45/USB 2.0 for relay parameterization and configuration etc. with the help of PC. In case RS-232 port offered, suitable interfacing cable with one end having RS 232 port and other end USB 2.0 to be provided to connect with PC free of cost.</li> <li>4. Relays should generate GOOSE message as per IEC 61850 standard for interlocking and also ensure interoperability with third party relays.</li> </ol>
25.	Name Plate and marking	<p>Each IED shall be clearly marked with manufacturer's Name, type, serial no. and electrical rating data. Name plates shall be made of anodized aluminium with white engraving on black surface.</p>
26.	Performance Guarantee	<p>Relays will be guaranteed for the period of five years from the date of last dispatch.  Any problem in the said period should be attended free of charge inclusive of repair/replacement of relays/component (both H/W, S/W).</p>
27.	Type Test	<ul style="list-style-type: none"> <li>• Dielectric Withstand Test—IEC 60255-5</li> <li>• High Voltage Impulse Test, class III---IEC 60255-5(5kV peak, 1.2/50</li> </ul>

		<p>microSec;3 Positiveand3 negativeshotsatintervalof 5Sec.)</p> <ul style="list-style-type: none"> <li>• DC SupplyInterruption----IEC 60255-11</li> <li>• AC Ripple onDCsupply----IEC 60255-11</li> <li>• VoltageDips andShortInterruptions--- IEC61000-4-11</li> <li>• HighfrequencyDisturbance---- IEC60255-22-1,ClassIII</li> <li>• FastTransient Disturbance ---- IEC 60255-22-4, Class-IV</li> <li>• Surgewithstandcapability ---- IEEE/ANSIC37.90.1(1989)</li> <li>• DegreeofProtection</li> <li>• Electromagneticcompatibility</li> <li>• Mechanicalstress/vibrationtest</li> <li>• Temperaturewithstand</li> </ul> <p>Typetestreportsforthe abovetests shall besubmitted forthe approvalof EMPLOYERalongwith Tender,failingwhichorder may be rejected.</p> <p>WherevertheabovementionedstandardsandIEC61850overlap,the latterwillprevail.</p>
28.	Training	<p>Suitabletrainingtobeimpartedtoemployerpersonsonthefollowingitem s:-</p> <ol style="list-style-type: none"> <li>1. Relaysettingandparameterization</li> <li>2. RelayconfigurationwithrespecttoI/P,O/Pandfunctionalblock for protection.</li> <li>3. GOOSE configuration.</li> <li>4. Configuration and Interfacing required for third party SCADA SystemIntegration.</li> <li>5. Diagnosticfeatures</li> </ol> <p>Thedetailsofsyllabustobefinalized withEMPLOYER.</p>
29.	Service Charge for Commissioning Engineer	<p>Firmrateshallbequotedseparatelyforcommissioningandintegrationof RelaywithSCADAasperformat.Thisrateshallbevalidforthreeyears fromduedateofsubmissionoftender.However,theabovecostwillnot beconsidered for evaluation.</p>



**Inter-operability test:-**

After fulfilment of the above Q.R. inter-operability test of the offered relay (other than Make & Model used in EMPLOYER) with the existing relay in EMPLOYER Network will be tested in EMPLOYER Distribution Testing Department, EMPLOYER for which due intimation for supply of sampled of offered relay will be given to the Manufacturer. The Manufacturer needs to submit the said relay to Distribution Testing Department, EMPLOYER within one week from the said intimation.

The offered relay will only be accepted after fulfilment of above Q.R. & successful inter-operability test at EMPLOYER system.

**Checklist for Bill of Material for supply**

Sl.No.	Material	
1.	Relay (Model No.)	Qty as per Tender
2.	Lugs suitable for current and control, wiring	Qty as per Tender X Number of TBs in relay + 20% extra.
3.	Cable for connection of Relay to laptop (USB port). Along with converter and power supply if required for relay local setting	10 set
4.	Manual, Hard copy in good quality paper properly bounded	10 set
5.	Copy of Type Test certificate along with manual	With offer
6.	Basic application software for setting change,	10 nos.
7.	CD with software (licensed ) to download disturbance recorder, event log and evaluation of those records	10 nos.
8.	Graphical configuration tool for I/P, O/P and functional building block for protection	10 nos.
9.	Any other software required for integration with SCADA.	10 nos.

**N. All the above tools/Softwares should be compatible to WINDOWS XP/WINDOWS NT/WINDOWS 7 Operating System.**

**ANNEXURE-II**

**Technical specification for IEC 61850 compliant Directional O/C and E/F Relay with Bay control features**

Sl.No	Feature and Function	Technical requirement
1	Purpose and application	<p>It is intended to automate the Switchgear specified in the scope of supply and use Communicable Numeric relays for Protection, Control, Metering and Status monitoring. This specification is based on the understanding that an integrated Automation System along with protection shall be provided and same shall have provisions for Integration with SCADA system. All the feeders shall be remote controlled from EMPLOYER'S SCADA and from the local console of the numerical relays.</p> <p>Numerical multifunctional combined Microprocessor based Feeder protection and management relay to protect the 33kV Parallel Feeder from all electrical and other faults along with reporting system, Disturbance record for fault analysis. Manufacturers should comply with any special requirement or feature asked for retrofitting the relays. Relay should be IEC 61850 compliant. Relay should have 4 CT input, 3 input for O/C and residual E/F protection will be derived internally. One CT input may be used for unbalanced current protection. Relay should have 4 voltage input, 3 input for VT element for directional O/C protection with internally derived residual voltage for E/F protection. Another VT input will be used for residual voltage protection. Relay should have two stage overvoltage and under voltage protection.</p>
2	Main Protection Feature for directional O/C & E/F relay.	<ol style="list-style-type: none"> <li>1. Electrical overload protection with selectable IEC curves with two stage, first stage to be used as Definite Time/IDMT and second stage to be used as high set for short circuit protection.</li> <li>2. Earth fault protection in two stages with IEC characteristics. First stage to be used as IDMT/Definite Time and second stage to be used as instantaneous elements. Earth fault elements should be suitable for both CBCT and residual type CT connection.</li> <li>3. Negative phase sequence Protection with IEC Curves.</li> <li>4. CB Fail Protection &amp; time settable as per user.</li> <li>5. The relay should be immune to DC switching while carrying</li> </ol>
		<p>current, i.e. no spurious trips should be generated if relay DC is made On and Off</p> <ol style="list-style-type: none"> <li>6. The relay should conform to the IEC 255-4 or BS142 for Inverse time characteristics.</li> <li>7. VT fuse fail detection on NPS current/NPS Voltage or zero sequence current/voltage based logic and blocking of undervoltage protection by VT fuse fail detection.</li> <li>8. Three phase VT fuses fail detection on current based logic.</li> <li>9. The relay should have features to monitor for broken conductor and CB opening time.</li> <li>10. The relay shall be designed for application in EMPLOYER'S distribution network where the system is non-effectively earthed through earthing transformer emanating at 33kV bus of 132/33kV substation.</li> <li>11. Relay should have minimum two group of setting. Setting group change over required from digital status input.</li> </ol>

3.	Processor feature	Relays shall be completely Numerical with protective elements having software algorithm based on sampling of analog inputs. Sampling Rate of Analog Signal: The sampling rate should be 1000Hz for 50Hz signal or better for each analog channel. Hardware based measurements shall not be acceptable.
4.	Operational Philosophy	The operation of Relay shall be possible from both locally from the Switchgear and remote and Local Workstation. The local position shall be displayed in remote/local workstation and remote operations shall be blocked if the switch is in Local. Clear control priorities shall prevent initiation of operation of a single switch at the same time from more than one of the various control levels and there shall be interlocks among various control levels. The priority shall always be with the lowest enabled control level. Relay accuracy shall not be affected by system frequency fluctuation.
5.	Status/Optical Inputs/Digital inputs	<ol style="list-style-type: none"> <li>1. Minimum 7 number status inputs are required</li> <li>2. All status inputs should be 30VDC/110VDC (will be mentioned during detailed Engineering as per requirement)</li> <li>3. Setting group is required to be changed with any Digital input status.</li> <li>4. Trip circuit supervision with DI status</li> <li>5. The digital inputs shall be acquired by exception with 1ms resolution. Contact bouncing in digital inputs shall not be assumed as change of state.</li> <li>6. Relays should have comprehensive self diagnostic feature with remote indication of relay failure and alarm shall be generated without tripping of circuit</li> <li>7. Provision of Testing output relays without any current injection.</li> <li>8. No. of programmable LEDs - at least 4 nos. with latching option.</li> </ol>
6.	Main measuring and reporting feature	<p style="text-align: center;">All measurements should be in primary quantities. Minimum following displays are required in alpha numeric:-</p> <ol style="list-style-type: none"> <li>1. Three phase (Positive sequence) current, Three phase voltage</li> <li>2. Neutral (zero sequence) current, MW, MVAR, Frequency, Pf, MVA etc.</li> <li>3. All the trips should have clear indication on the relay terminals</li> <li>4. Resettings should be selectable as hand reset or auto reset.</li> </ol>

7.	Memory and Recording Feature	<ol style="list-style-type: none"> <li>1. The relay setting and programming should be stored in EEPROM so that during Aux. Power failure the said data is not lost.</li> <li>2. Relays should have event log, trip log and DR record. All logs should go into history.</li> <li>3. All tripping of relay should initiate DR in auto without extra binary input. Triggering of DR with binary input should be user configurable.</li> <li>4. The last 2 fault DR records should be in flash memory and DR will not erase in case of DC supply fail for more than 2 days.</li> <li>5. Should be able to record at least 5 Oscillographic disturbances and 5 fault records and 250 event records.</li> <li>6. Minimum Four no. of latest trip log with cause of trip should be stored in memory along with date and timestamping. The memory should not be lost with the switching off of DC.</li> <li>7. The relay should have fault-recording feature with current waveform and Digital Input status. The fault waveform should consist of minimum four current waveform of three phase current and zero sequence current and DI status. Triggering time for Pre and Post should have user selectable. This record should be in flash memory for minimum 7 days even after switching off the DC supply.</li> <li>8. The fault should be date and timestamped.</li> <li>9. Communication protocol IEC 61850.</li> </ol>
8.	Auxiliary Supply	<p>30V or 110VDC (will be mentioned during detailed Engineering as per requirement) to -25% to +10%, 2 wire unearthened system. Necessary software shall be in-built for proper shutdown and restart in case of power failure. Auxiliary supply burden will be around 20Watt.</p>
9.	Rated CT/PT secondary	<p>5/1Amp (site selectable), CT used to be protection class.  3PT input rated 110V (L-L)</p>
10.	Rated frequency	<p>50HZ +/- 5%</p>
11.	Ambient condition	<ol style="list-style-type: none"> <li>1. Operating ambient temperature upto 55 DegC</li> <li>2. Operating Humidity upto 100%</li> <li>3. Relay shall meet the requirement for withstanding electromagnetic interference according to relevant parts of IEC 61850. Failure of single component within the equipment shall neither cause unwanted operation nor lead to a complete system breakdown.</li> </ol>
12.	Module and Mounting	<ol style="list-style-type: none"> <li>1. Relay should be flush mounted type</li> <li>2. If module is draw out type then it should have CT shorting facility of make before break type.</li> <li>3. Mounting in switch gears located in non AC rooms.</li> <li>4. Galvanic isolation between field connection and relay hardware should be there.</li> </ol>

13.	Watchdogandself monitoring	<p>The relays should have facility to monitor the healthiness of its circuits and components by own monitoring system. In case of any problems, the alarm should be generated by one of the output contacts. The alarm as soft signal to be sent to SCADA system as well. Necessary support documentation explaining the self diagnostic feature shall be furnished. Watchdog contact shall be provided in addition to required 7BI and 7BO.</p>
14.	Settings	<p>Approximate settings possible should be as follows:-</p> <ol style="list-style-type: none"> <li>1. Nominal Feeder current 2% to 110%</li> <li>2. CTRatio setting 10-1000 (approx.)</li> <li>3. Earth fault current 5 to 40% with time delay IEC Curves, 2<sup>nd</sup> stage for instantaneous trip (less than 50 ms)</li> <li>4. Overcurrent trip - 50% to 200% of 1/5 Amp with time delays as per IEC Curves.</li> <li>5. High set with delay 200% to 2000%</li> <li>6. IEC Curves for all O/C and E/F have user selectable.</li> <li>7. Selectable MTA for Directional features for O/C relay should cover 1<sup>st</sup> quadrant for effectively grounded system / impedance grounded system / solid grounded system.</li> </ol>
15.	Output Relays	<p>Minimum 7 number output relays are required out of which</p> <ol style="list-style-type: none"> <li>1. One potential free change over contact should be provided for start inhibit of relay.</li> <li>2. All o/p contacts should be freely programmable.</li> <li>3. Rating of trip contacts:-             <ol style="list-style-type: none"> <li>a) Contact durability &gt; 10K operation</li> <li>b) 15 Amp make and carry for 3 sec for trip contact</li> <li>c) Make and carry for trip contacts L/R ≤ 40ms</li> <li>d) 8 Amp make and carry continuously for 5 sec.</li> </ol> </li> </ol> <p>Testing of Output relays through keypad on relay fascia and relay HMI software. Output relay dwell time shall be user programmable or fixed at 100ms.</p>

<p><b>16.</b></p>	<p><b>Relay software and ManMachine Interface</b></p>	<ol style="list-style-type: none"> <li>1. The relay should have native IEC 61850 Communication Protocol.</li> <li>2. Should have password protected keypad lock.</li> <li>3. Necessary software for relay setting, retrieving DR, event log, trip log, and downloading waveform should be supplied by the Manufacturer. Necessary License should be issued for EMPLOYER, if required.</li> <li>4. Manufacturer has to supply communication hardware for relay setting, DR downloading from front port. This device should be compatible to USB/Ethernet port.</li> <li>5. It shall be possible to transfer the data stored in the DFR to computer on IEEE/COMTRADE format. The data format shall be compatible for dynamic protection relay testing on relay test kit. COMTRADE Data viewer software is to be provided.</li> <li>6. Multiuser/Corporate license for installation on minimum 7 nos. of PCs.</li> </ol>
<p><b>17.</b></p>	<p><b>Date and time</b></p>	<p>Date and Timestamping with faults and record. The clock should be powered from internal cell and should not require setting after every DC switching. The internal cell life minimum 5 years. Time synchronization by IRIG-B or SNTP. For time synchronization through SNTP is to be provided from clock signal coming from RTU. In case of IRIG-B, time synchronization will be done with GPS clock signal from GPS receiver located at substation.</p>
<p><b>18.</b></p>	<p><b>Lugs and terminators</b></p>	<p>All CT and PT terminals shall be provided as fixed (screwed) type terminals on the relay to avoid any hazard due to loose connection leading to CT opening or any other loose connection. Necessary amount of lugs should be supplied along with each relay for CT connection and control wiring.</p>
<p><b>19.</b></p>	<p><b>Manuals, Drawings and Literature</b></p>	<ol style="list-style-type: none"> <li>1. The relays should be supplied with manuals with all technical and operating instructions.</li> <li>2. All the internal drawings indicating the logics and block diagram detail explaining principle of operations should be given at the time of supply.</li> <li>3. Mapping details shall be submitted in IEC format.</li> </ol>
<p><b>20.</b></p>	<p><b>Standard documentation per Relay, according to IEC 61850</b></p>	<ol style="list-style-type: none"> <li>1. MICS document (model implementation conformance statement)</li> <li>2. PICS (protocol implementation conformance statement)</li> <li>3. Conformance Test certificate from KEMA/CPRI.</li> <li>4. PIXIT document</li> </ol> <p>All the above mentioned certificates shall be submitted along with Order copy</p> <ol style="list-style-type: none"> <li>5. ICD file</li> <li>6. SCD file</li> </ol>

<p><b>21.</b></p>	<p><b>Extendibility in Future</b></p>	<p>The Manufacturer shall provide all necessary software tools along with source code to perform addition of bays in future and complete integration with SCADA by the User. These software tools shall be able to configure relay, add analog variable, alarm list, event list, modify interlocking logics etc. for additional bays/ equipments which shall be added in future.</p>
<p><b>22.</b></p>	<p><b>Lifespan</b></p>	<p>The suppliers should mention following:-</p> <ol style="list-style-type: none"> <li>1. Product maturity: The Manufacturer should mention the time period for which the product is in the market</li> <li>2. Expected production life</li> <li>3. Hardware/Firmware change notification process. Upgrade to be provided free of cost within the Guarantee period/5 years whichever is later, if needed.</li> <li>4. Lifespan of standard tools and processes for relay configuration, querying and integration.</li> </ol>
<p><b>23.</b></p>	<p><b>Standards</b></p>	<p>The relays should conform to the IEC 255-5 or equivalent BS/ANSI for following:-</p> <ol style="list-style-type: none"> <li>1. Overload withstand test</li> <li>2. Dielectric withstand: 2kV in common, 1kV in differential mode</li> <li>3. Impulse Voltage: 5kV in common, 1kV in differential mode</li> <li>4. Insulation resistance &gt; 100M ohm</li> <li>5. Vibration: Shock and bump and Seismic</li> <li>6. Storing and transportation</li> <li>7. Radio Interference: IEC 61000 for high frequency disturbance, Transient disturbance, Electrostatic discharge</li> <li>8. KEMA/CPRI Certification for the particular model offered with respect to IEC 61850 Protocol</li> </ol>

<p><b>24.</b></p>	<p><b>CommunicationPort</b></p>	<p>1. Two nos. IEC 61850 protocol compliant Ethernet RJ45/F.O port for communication with SCADA system through two managed Ethernet Switches operating in redundant mode. The communication shall be made in 1+1 mode between individual IED to Switch, such that failure of one set of LAN shall not affect the normal operation of SCADA. However, it shall be alarmed in SCADA.</p> <p>2. Functioning of Relay shall not hamper to fault occurring any interconnected relay.</p> <p>3. One Front port Ethernet RJ45/USB 2.0 for relay parameterization and configuration etc. with the help of PC. In case RS-232 port offered, suitable interfacing cable with one end having RS 232 port and other end USB 2.0 to be provided to connect with PC free of cost.</p> <p>4. Relay should generate GOOSE message as per IEC 61850 standard for interlocking and also ensure interoperability with third party relays.</p>
<p><b>25.</b></p>	<p><b>Name Plate and marking</b></p>	<p>Each IED shall be clearly marked with manufacturer's Name, type, serial no. and electrical rating data. Name plate shall be made of anodized aluminium with white engraving on black surface.</p>
<p><b>26.</b></p>	<p><b>Performance Guarantee</b></p>	<p>Relays will be guaranteed for the period of five years from the date of last dispatch.</p> <p>Any problem in the said period should be attended free of charge inclusive of repair/replacement of relays/component (both H/W, S/W).</p>



<p><b>27.</b></p>	<p><b>Type Test</b></p>	<ul style="list-style-type: none"> <li>• Dielectric Withstand Test—IEC 60255-5</li> <li>• High Voltage Impulse Test, class III---IEC 60255-5(5kV peak, 1.2/50 microSec; 3 Positive and 3 negative shots at interval of 5Sec.)</li> <li>• DC Supply Interruption ----IEC 60255-11</li> <li>• AC Ripple on DC supply----IEC 60255-11</li> <li>• Voltage Dips and Short Interruptions--- IEC 61000-4-11</li> <li>• High frequency Disturbance---- IEC 60255-22-1, Class III</li> <li>• Fast Transient Disturbance ---- IEC 60255-22-4, Class-IV</li> <li>• Surge withstand capability ---- IEEE/ANSI C37.90.1(1989)</li> <li>• Degree of Protection</li> <li>• Electromagnetic compatibility</li> <li>• Mechanical stress/vibration test</li> <li>• Temperature withstand</li> </ul> <p>Type test reports for the above tests shall be submitted for the approval of EMPLOYER along with Tender. Wherever the above mentioned standards and IEC 61850 overlap, the latter will prevail.</p>
<p><b>28.</b></p>	<p><b>Training</b></p>	<p>Suitable training to be imparted to employer's persons on the following items:-</p> <ol style="list-style-type: none"> <li>1. Relay setting and parameterization</li> <li>2. Relay configuration with respect to I/P, O/P and functional block for protection.</li> <li>3. GOOSE configuration.</li> <li>4. Configuration and Interfacing required for third party SCADA System Integration.</li> <li>5. Diagnostic features</li> </ol>
<p><b>29.</b></p>	<p><b>Service Charge for Commissioning Engineer</b></p>	<p>Firm rates shall be quoted separately for commissioning and integration of Relay with SCADA as per format. This rate shall be valid for three years from due date of submission of tender. However, the above cost will not be considered for evaluation.</p>

<p>30.</p>	<p>Credential as pre-requisite of Tender</p>	<p>1. Copies of performance certificate for two years successful operation as on the due date of bid opening for the offered relay in respect to implementation of IEC 61850 protocol to any SCADA/substation automation system from reputed Power Sector Utility in India shall have to be furnished along with the Bid. Copies of Purchase Orders and corresponding Delivery Challans/Stores Receipt vouchers/Excise Duty Invoice, etc., i.e. Proof of Execution of the Purchase Orders.</p> <p>OR</p> <p>Successful testing and operation of minimum one year in EMPLOYER network..</p> <p>2. Documentary evidence for being manufacturers like registration Certificate issued by SSI/NSIC/Directorate of Industries/DGS&amp;D, etc. for Qualifying requirement.</p> <p>3. The manufacturers should have testing facilities of all functional tests or should have arrangement of all functional tests at government approved testing laboratories.</p> <p><b><u>Inter-operability test:-</u></b></p> <p>After fulfilment of the above Q.R. inter-operability test of the offered relay (other than Make &amp; Model used in EMPLOYER) with the existing relay in EMPLOYER Network will be tested in EMPLOYER Distribution Testing Department, EMPLOYER for which due intimation for supply of sampled of offered relay will be given to the Manufacturer. The Manufacturer needs to submit the said relay to Distribution Testing Department, EMPLOYER within one week from the said intimation.</p>
------------	--	---

**ChecklistforBillof Materialfor supply**

<b>Sl.No.</b>	<b>Material</b>	
1.	Relay(Model No.)	Qtyas perTender
2.	Lugs suitableforcurrent andcontrol,wiring	QtyasperTenderXNumber of TBs in relay+20%extra.
3.	CableforconnectionofRelaytolaptop(USBport). Along with converter and power supply if required forrelaylocal setting	10set
4.	Manual,Hardcopyingoodqualitypaperproperly bounded	10set
5.	CopyofTypeTestcertificatealongwithmanual	With offer
6.	Basic applicationsoftware for settingchange,	10nos.
7.	CD with software(licensed ) to download disturbancerecorder,eventlogandevaluationof thoserecords	10nos.
8.	Graphical configuration tool for I/P, O/P and functional buildingblockfor protection	10nos.
9.	Anyothersoftwarerequiredforintegrationwith SCADA.	10nos.

**N.B All the above tools/ Software should be compatible to WINDOWS XP/WINDOWS NT/WINDOWS70peratingSystem.**

QUALITY ASSURANCE PLAN (Annexure-III)

The manufacturers shall invariably furnish following information along with this offer.

(1) Statement giving list of important raw materials including but not limited to

- (a) Contact material
- (b) Insulation
- (c) Sealing material
- (d) Contactor, limit switches, etc. in control cabinet.

Name of sub-suppliers for the raw materials, list of standards according to which the raw materials are tested, list of tests normally carried out on raw materials in presence of Manufacturer's representative, copies of test certificates.

2) Information and copies of test certificates as in (i) above in respect of bought out accessories.

3) List of areas in manufacturing process, where stage inspections are normally carried out for quality control and details of such tests and inspections.

4) Special features provided in the equipment to make it maintenance free.

5) List of testing equipment available with the Manufacturer for final testing and associated combinations vis-à-vis, the type, special, acceptance and routine tests specified in the relevant standards. These limitations shall be very clearly brought out in the relevant schedule i.e. schedule of deviations from specified test requirements. The supplier shall, within 15 days from the date of receipt of Purchase Order submit following information to the EMPLOYER:-

i) List of raw materials as well as bought out accessories and the names of sub-suppliers selected from those furnished along with offer.

ii) Necessary test certificates of the raw material and bought out accessories.

iii) Quality Assurance Plan (QAP) with hold points for EMPLOYER's inspection. The quality assurance plan and hold points shall be discussed between the EMPLOYER and supplier before the QAP is finalized.

iv) The supplier shall submit the routine test certificates of bought out items and raw material, at the time of routine testing of the fully assembled Panel.

**10. Batteries and Charger**

Lead Acid or Ni-Cd, any one of these two can be used by contractor. Both the specification along with specification for their charger are given below:

**I. Ni-Cd ALKALINE BATTERIES (PARTIAL RECOMBINATION TYPE) WITH CHARGERS FOR 33/11 kV AND 66/11 kV SUB-STATIONS**

**Part-A :Ni-Cd ALKALINE BATTERIES (PARTIAL RECOMBINATION TYPE) FOR 33/11 kV AND 66/11 kV SUB-STATIONS**

**1) SCOPE**

This specification covers the requirements and tests for 24 V, 30 V 110 V, 220V partial recombination type Nickel-Cadmium alkaline batteries with chargers, for use in 33/11 kV and 66/11 kV sub-stations.

The batteries covered in this specification are for indoor use. For out-door application a suitable enclosure shall be provided, preferably made of an insulating material like FRP/SMC/DMC/Poly carbonate plastic material, heat/alkali/humidity/UV resistant, confirming to S1 or D1 grade of IS: 13410/IS: 13411 or other relevant international standard, in order to have rust free enclosure. The enclosure shall have rainproof ventilating louvers backed with fine brass wire mesh & suitable canopy. The enclosures shall confirm to IP: 52 degree of protection.

**2. APPLICABLE STANDARDS**

All standards, specifications and codes of practice referred to herein shall be the latest editions including all applicable official amendments and revisions as on date of opening of bid. In case of conflict between this specification and those (IS codes, standards etc.) referred to herein, the former shall prevail. Unless otherwise modified in this specification, the Ni-Cd batteries shall comply with latest version of IEC 62259.

All work shall be carried out as per the following standards and codes.

Sl.No.	International Standards	Indian Standards	Description
1	IEC: 62259	-	Secondary cells and batteries containing alkaline or other non-acid electrolytes-Nickel-cadmium prismatic secondary single cells with partial gas recombination
2	IEC: 60623	IS: 10918	Secondary cells and batteries containing alkaline or other non-acid electrolytes-vented Nickel_Cadmium prismatic rechargeable single cells
3		IS: 1146	Rubber & Plastic container for lead acid storage

Sl.No.	International Standards	Indian Standards	Description
			batteries
4	IEEE: 1106		Recommended practice for maintenance, testing & replacement of Ni-Cd storage batteries for generating stations & substations
5	IEEE: 1115		Recommended practice for sizing of Ni-Cd batteries for stationary applications
6		IS 13410	Glass reinforced Polyester sheet moulding compounds.
7		IS: 1248	Voltmeter

**3. STANDARD RATING**

The recommended voltage ratings of batteries, for use at 33/11 KV and 66/11 KV sub-stations, shall be 24 volts or 30 volts. The batteries for the above application shall have a rating of 45 Ah (Minimum) in case of 24 V battery system or as per the load requirement of the substation.

**Note:** Utilities may specify 110 or 220 V DC system if so required. For batteries intended for use with individual or groups of breakers or with higher DC System voltage, lower Ah ratings can be used depending upon the requirements.

**4. CELL VOLTAGE**

The nominal voltage of a single cell shall be 1.2 V

Nominal Voltage Rating of battery	Nominal single cell voltage	Float cell voltage	Number of cells (to be finalized)	Permissible D.C. System voltage variation	End of discharge cell voltage (Min.)
(V)	(V)	(V)	(V)	(V)	(V)
24	1.2	1.4 to1.42	19	21.7 to 27	1.14
30	1.2	1.4 to1.42	23	26.2 to 32.7	1.14
110	1.2	1.4 to 1.42	87	99.2 to 123.5	1.14

220	1.2	1.4 to1.42	170	193.8 to 241.4	1.14
-----	-----	------------	-----	----------------	------

Note: As the nominal cell voltage is 1.2 V, nominal battery bank voltage may not exactly match nominal DC system voltage.

**5. CAPACITY AT 20°C TEMPERATURE**

Battery capacity shall be decided based on the following load cycle:-

- (a) 800W for 1/2 minuteto end cell voltage of not less than 1.14 V per cell considering loads (i) to (iv) below.
- (b) 300 W for 1 hour to end cell voltage of not less than 1.14 V per cell considering loads (iii) & (iv) below.
- (c ) 100W for 05 hrs to end cell voltage of not less than 1.14 V per cell considering loads (iv) below.

The load cycle has been decided based on the following considerations:-

- (i) Tripping of 03 Nos. circuit breakers simultaneously with battery for which a total load of 500 W has been considered.
- (ii) Closing of 3 circuit breakers one after the other for which a load of 500 W per circuit breaker has been considered.
- (iii) Emergency lighting load of 200 W for 01 hour.
- (iv) 100 W load for panel indication lamps, relays, PLCC/ VHF communication systems, computer etc. for a period of 06 hours.

**6. BATTERY SIZING**

The supplier shall carry out battery sizing calculations based on the load cycle specified in line with IEEE 1115 and submit the same to the owner justifying the type/number of cells considered against the requirement.

Following factors shall be considered while carrying-out battery sizing calculations:-

- a) Ageing factor – 1.25
- b) Design margin –1.0
- c) State of charge –0.9

The number of cells shall be determined as per load cycle and the battery system voltage level. The owner, if required for the battery system, may specify provision for the number of spare cells.

**7. CONSTRUCTION**

The cells shall have prismatic, spill-proof type of construction with partial recombination feature. The cells shall be flooded type containing sufficient reserve electrolyte. Battery shall be equipped with nickel-plated inter-cell connectors and terminals. The cells shall be housed in high-strength impact resistant & alkali-resistant containers and should be transparent / translucent to facilitate checking of electrolyte level. Container and Lid should bewelded and should not cause leakage of electrolyte/gases during operation even in case of normal mechanical/electrical abuses. O-rings of

nitrile rubber with Epoxy sealing shall be used to ensure proper sealing of bushings etc. Flip-top vent plugs/ valves with flame arrester feature shall be provided. The regulating valve type design shall be of self-resealing type. Construction of cells shall be so as to ensure proper air circulation between the cells for heat dissipation/ ventilation (by providing either insulated button separators integral with the outer surface of the cell container or by suitably designing the inter cell connectors). The containers shall be strong enough, so that excessive bulging of container does not occur during service. Cells shall be supplied in filled & charged state or otherwise electrolyte in dry form & battery water separately or electrolyte in liquid form shall be shipped as desired by the owner.

Battery shall have provision for water top up to ensure electrolyte level does not fall below recommended level.

**8. ELECTRODES**

Electrodes shall be deigned for maximum durability under all service conditions. + ve and –ve electrodes shall be made by encapsulating/impregnating active material in order to ensure that the battery is able to perform reliably over its life. +ve and –ve electrodes shall be separated by micro porous separators. The structure of electrodes shall be elastic enough to absorb mechanical stresses & volume changes during charge/discharge cycles.

**9. ELECTROLYTE**

The electrolyte shall be prepared from battery grade potassium hydroxide (KOH) confirming to IEC 60993. The cells shall contain sufficient reserve electrolyte for efficient heat dissipation &to reduce water topping up interval. Reserve electrolyte shall not be less than 06 ml/Ah.

**10. CONNECTORS**

Nickel-plated copper inter-cell connectors shall be used forconnecting up adjacent cells and rows. Bolts, nuts and washers shall be nickel-plated steel/stainless steel. All terminals and cell inter-connectors shall be fully insulated or have insulation shrouds.

**11. TERMINALS**

Separate terminals shall be provided on the end cell for connecting load through DCDB and for connecting charger leads. All terminals shall be of suitably sized nickel-plated steel. Suitable nickel-plated copper lugs shall be provided by the supplier for use of the purchaser for connecting up the load wiring. All connectors and leadsshall be suitable for carrying 30-minute discharge current continuously and rated for short circuit duty of 4kA for 01 second.

**12. MANUAL OF INSTRUCTIONS**

The manufacturer shall supply a copy of the instruction manual for commissioning & initial treatment of the battery and maintenance during service with every battery bank ordered.

**13. RECOMBINATION EFFICIENCY**

In order to reduce topping-up frequency, recombination of Hydrogen & Oxygen gases evolved during charging/discharging shall be achieved by using safe and reliable technology such as catalytic conversion/valve regulation technique or both. Minimum recombination efficiency shall be 80%. Recombination efficiency test shall be done in accordance with IEC 62259. In case the batteries are



operated at high temperatures & are frequently boost charged the water consumption may be higher & topping-up frequency may increase.

**14. BATTERY RACKS**

Suitable corrosion resistant battery racks and cable supports shall be provided. Metallic racks shall be properly earthed. The bottom tier of stand shall have a ground clearance of 150mm minimum above the floor. Racks shall be made of alkali resistant powder coated steel or stainless steel or FRP to ensure corrosion resistance.

**15. TEMPERATURE RANGE**

Battery must be capable of continuous operation in temperatures range of -15°C to +50°C for prolonged periods. No Air-conditioning shall be provided where batteries are to be installed.

**16. ACCESSORIES**

The following accessories (BIS certified) shall be supplied with each set of battery:-

- i) Clamp-on type digital multi-meter of AC/DC current range having ISI mark.
- ii) Pair of gloves
- iii) 10" Slide insulated wrench for opening terminal nuts
- iv) Plastic/glass syringe
- v) Alcohol thermometer
- vi) Hydrometer for use while filling electrolyte.

**17. CHARGE RATE**

Fully discharged batteries should be able to get recharged in 7 hours maximum to 90% of capacity with charging current in the range of 0.1 to 0.4CmA rate at 20°C. At higher temperatures, the charging time may be more. The trickle charge rate shall be 1-2 mA/Ah.

**18. CELL DESIGNATION**

The practice as per IS: 10918 (latest version) shall be followed.

**19. POLARITY MARKING**

The polarity of the terminals shall be marked for identification. Positive terminal may be identified by 'P' or a (+) sign or red colour mark and negative terminal may be identified by 'N' or (-) sign or blue colour mark. Marking shall be permanent and non-deteriorating.

**20. WARNING MARKING**

The battery shall be furnished with a warning plate located at conspicuous place specifying the use of 'ALKALINE ELECTROLYTE ONLY' (in block letters) and specifying proper filling level of the electrolyte. Marking shall be permanent and non-deteriorating.

**21. PACKING**

The batteries shall be securely packed in wooden crates suitable for handling during transit by rail/road and secured to avoid any loss or damage during transit. Carton boxes duly palletized shall also be acceptable.

**22. TESTS**

The batteries shall be tested for type, acceptance and routine tests in line with IS: 10918 & IEC: 62259 (latest versions). The owner may at their discretion to accept the batteries based on type tests already carried-out. In such cases, Type test reports for tests carried out not earlier than 05 years from bid opening date from NABL accredited labs shall be acceptable.

Note : In case Type tests are repeated, life cycle test may not be insisted upon Ni-Cd battery of the specific ratings to be ordered, as this test takes a long time (2-3 years). However, satisfactory evidence is to be furnished for having made this test on cell of any other Ah capacity of the same design.

**23. BUYBACK OF USED/UNSERVICEABLE BATTERIES**

Manufacturer shall buyback used/unserviceable batteries from the substations where batteries are replaced. The owner shall confirm the following particulars of used/unserviceable batteries to enable the bidder to quote buyback rates:

- i) Type & number of cells for disposal
- ii) Make
- iii) Year of make/purchase
- iv) Capacity
- v) Condition of cells

The bidder should quote their rates for buyback considering the salvage value of the above cells.

**24. SAFE DISPOSAL OF UNSERVICEABLE BATTERIES**

The bidder shall have facilities for proper treatment & disposal of used/unserviceable batteries that are bought back from the users, in line with the environmental protection rules & regulations of the country.

**25. GUARANTEE**

The batteries shall be guaranteed for a period of 36 months from the date of commissioning.

**Part B : CHARGER FOR Ni-Cd BATTERY (RECOMBINATION TYPE)**

**1. SCOPE**

This specification covers the requirements and tests for Battery charger for partial recombination type Nickel-Cadmium alkaline batteries for use in 33/11 KV and 66/11 KV sub-stations.

**2. CODES AND STANDARDS**

**2.1.** All standards, specifications and codes of practice referred to herein shall be the latest editions including all applicable official amendments and revisions as on date of opening of bid. In case of conflict between this specification and those (IS codes, standards etc.) referred to herein, the former shall prevail. All work shall be carried out as per the following standards and codes.

**2.2.**

Sl.No	International standards	Indian standards	Description
1		IS:5	Colours for ready mix paints.
2		IS : 1248	Direct acting indicating analogue electrical measuring instruments.
3	IEC : 947-1	IS : 13947 Prt-1	Low voltage switchgear and control gear - General.
4	IEC : 947-2	IS : 13947 Prt.-2	Low voltage switchgear and control gear - Circuit Breaker
5	IEC : 947-3	IS : 13947 Prt-3	Specification for low voltage switchgear and control gear – Switches, Disconnectors, Switch disconnectors & Fuse combination units.
6	IEC : 947-4	IS : 13947 Prt-4	Specification for low voltage switchgear and control gear –Contactors
7		IS : 13947 Prt-5	Specification for low voltage switchgear and control gear – Control Circuit Devices & Switching Elements
8	IEC: 439	IS:8623	Low voltage switch-gear and control-gear assemblies
9		IS:8686	Static protective relays
10	IEC:225	IS : 3231	Electrical relays for power system protection.
11		IS : 3842	Application guide for Electrical relays for AC System
12	IEC 146	IS : 3895	Mono-crystalline semi-conductor Rectifier Cells and Stacks.
13	IEC 146	IS : 4540	Mono crystalline semi-conductor Rectifier assemblies and equipment.
14		IS:6619	Safety Code for Semi-conductor Rectifier Equipment.

15		IS : 9000	Basic environmental testing procedures for electronic and electrical items.
16	IEC: 60269	IS:13703 Prt-4	Low voltage fuses for protection of semiconductor devices.
17		IS:1901	Visual indicating lamps
18		IS:6005	Code of practice for phosphating of Iron and Steel.
19	IEC: 227	IS:694 /IS: 1554	PVC Insulated Cable for working voltages upto and including 1100 V.

**2.3.** Equipment complying with other internationally accepted standards such as IEC, BS, VDE. etc. will also be considered if they ensure performance and constructional features equivalent or superior to standards listed above. In such a case, the Bidder shall clearly indicate the standard(s) adopted, furnish a copy in English of the latest revision of the standards along with copies of all official amendments and revisions in force as on date of opening of bid and shall clearly bring out the salient features for comparison.

**3. EQUIPMENT DESCRIPTION**

**3.1. a)** The Battery Chargers as well as their automatic regulators shall be of static type. Battery chargers shall be capable of continuous operation at the respective rated load in Float mode, i.e. Float charging the associated Ni-Cd Batteries (partial recombination type) while supplying the D.C. loads. The Batteries shall be Float charged at 1.4 to 1.5 Volts per cell. All chargers shall also be capable of Boost Charging the associated Batteries at 1.42 to 1.7 Volts per cell at the desired rate. The Chargers shall be designed to operate, as mentioned above, up-to an ambient air temperature of 50°C. Tapping arrangement in the battery bank shall be provided to limit the over-voltage for supplying load within allowed voltage range under boost charge conditions. The charger should automatically switchover to float charge & to boost charge when the specified limit of voltage is approached. However, necessary timer circuit shall be used to allow a finishing charge before switching over to float mode, as recommended by battery manufacturer in order to ensure that battery gets fully charged. Recommended values of charger rating, tapping cell and specified voltages for automatic changeover to float/boost mode are given in table below, however, the manufacturer may suggest any changes in the recommended values with justification at the time of supply :

<b>Rating of Charger</b>	<b>Charger Rating during Float Charging at 1.4 to 1.45 V per cell</b>	<b>Charger Rating during Boost Charging at 1.42 to 1.7 V per cell</b>	<b>Tapping to be provided at ---th cell</b>	<b>Switching Voltage to Boost Mode</b>	<b>Switching Voltage to Float Mode</b>

<b>Volt</b>	<b>Ampere</b>	<b>Ampere</b>	<b>n</b>	<b>Volt</b>	<b>Volt</b>
24	10	25	15	22	32
30	10	25	18	26	38
110	5	5	69	94	146
220	5	5	136	194	285

Note : Charger rating shall be arrived at with charger in boost mode and also supplying 100% float load i.e. charger current shall be sum of float & boost rating.

- b) Battery Chargers shall automatically select the appropriate mode of operation i.e. Float or Boost. Means shall be provided to avoid current/voltage surges of harmful magnitude/nature, which may arise during changeover.
- c) Soft start feature shall be provided to build up the voltage to the set value slowly within fifteen seconds. The chargers shall have load limiters, which shall cause, when the voltage control is in automatic mode, a gradual lowering of the output voltage when the DC load current exceeds the load limiter setting of the Charger. The load limiter characteristic shall be such that any sustained overload or short circuit in DC system shall neither damage the Charger nor shall it cause blowing of any of the charger fuses. The Charger shall not trip on overload or external short circuit. After clearance of fault, the Charger voltage shall build up automatically when working in automatic mode.  
  
 During external short circuit, output of the charger shall be automatically reduced to near zero volt till it is not isolated/disconnected & normal output voltage shall be restored by charger circuit on isolation with out any harm to source transformer/protection/ regulator circuit
- d) During Float charging, the Charger output voltage shall remain within  $\pm 1\%$  of the set value for AC input voltage variation of 230 +10% -15%, frequency variation of  $\pm 5\%$ , a combined voltage and frequency (absolute sum) variation of 10% and a continuous DC load variation from 5% to full load. Uniform and stepless adjustments of voltage setting shall be provided on the front of the Charger panel covering the entire Float charging output range specified. Stepless adjustment of the load limiter setting shall also be possible from 80% to 100% of the rated output current for Float charging mode.
- e) During Boost charging, the Battery Chargers shall operate on constant current mode with maximum current limiter setting (When automatic regulator is in service).
- f) Energising the Charger with fully charged battery connected plus 10% load shall not result in output voltage greater than 110% of the voltage setting. Time taken to stabilise, to within the specified limits in clause 3.1 (d), shall be less than five seconds.
- g) Momentary output voltage of the Charger, with the Battery connected shall be within 90% to 110% of the voltage setting during sudden load Change from 80% to 20% of full load or vice-versa.

Output voltage shall return to, and remain, within the limits specified in clause 3.1 (d) in less than 1 second after the above-mentioned change.

- h) The Charger manufacturer may offer an arrangement in which the voltage setting device for Float charging mode is also used as output voltage limit setting device for Boost charging mode, and the load limiter of the float charging mode is also used as Boost charging current setting device.
- i) Suitable filter circuits shall be provided in all the Chargers to limit the ripple content (peak to peak) in the output voltage to 3% irrespective of the DC load, even when they are not connected to a battery.
- j) The DC System shall be ungrounded and float with respect to the ground potential when healthy.
- k) Battery shall be isolated in case of short circuit on the load side.
- l) Battery test circuit shall be provided with suitable resistance for discharging the battery for 30Sec at 5 hr rate.
- m) All potentiometers shall be electronically locked to contain the various parameters within allowable limits even if the setting position of potentiometers is changed to extreme positions.
- n) Insulation resistance shall be 5 M Ohm min.

### **3.2. MCB**

AC MCCB shall be provided at the incomer. DC MCCB with provision of auxiliary contacts shall be provided at the output of the battery charger.

### **3.3. Rectifier-Transformers and Chokes**

The rectifier transformer and chokes shall be dry and air cooled (AN) type. The rating of the rectifier-transformers and chokes shall correspond to the rating of the associated rectifier assembly. The rectifier-transformers and chokes shall have class-B insulation as per IS : 4540. Rectifier transformer shall confirm to all type tests as specified in IS 4540/IS 2026. Type test & routine test reports shall be submitted to the owner.

### **3.4. Rectifier Assembly**

The rectifier assembly shall be full wave bridge type and designed to meet the duty as required by the respective Charger. The rectifier cells shall be provided with their own heat dissipation arrangement with natural air-cooling. The rectifier shall utilise diodes/thyristors with heat sinks rated to carry 130% of the load current continuously and the temperature of the heat sink shall not be permitted to exceed 85°C absolute duly considering the maximum temperature inside charger panel with ambient temperature of 50°C. The Contractor shall submit calculations to show what maximum junction temperature will be and what the heat sink temperature will be when operating at 130% and 100% load current continuously duly considering the maximum surrounding air temperature for these devices inside the charger panel assuming ambient temperature of 50°C outside the panel. Necessary surge protection devices and rectifier type fast acting fuses shall be provided in each arm of the rectifier connections. Static silicon controlled rectifiers and diodes complete with resistor/capacitor network for surge protection shall be provided

Design having IGBT or superior technology shall also be acceptable for which full justification & experience shall be required for acceptance.

**3.5. Instruments**

Analog or digital D.C. voltmeter, D.C. ammeter and A.C. voltmeter with 96 mm square display shall be provided for all Chargers. The instruments shall be flush mounted type, dust proof and moisture resistant. The instruments shall have easily accessible means for zero adjustments. The instruments shall be of 1.5 accuracy class.

**3.6. Control and Selector Switches**

Control and selector switches shall be of rotary stayput type of reputed make, confirming to relevant IS with escutcheon plates showing the functions and positions. The switches shall be of sturdy construction and suitable for mounting on panel front. Switches with shrouding of live parts and sealing of contacts against dust ingress shall be preferred. The contact ratings shall be at least the following :

- i) Make and carry continuously - 10 Amps.
- ii) Breaking current at 220 V DC - 0.5 Amp. (Inductive)
- iii) Breaking current at 230 V AC - 5 Amp. at 0.3 p.f.

**3.7. Fuses**

Fuses shall be of HRC cartridge fuse link type. Fuses shall be mounted on fuse carriers, which are mounted on fuse bases. Wherever it is not possible to mount fuses on fuse carriers, they shall be directly mounted on plug in type bases. In such cases one insulated fuse pulling handle shall be supplied for each charger. Suitable fuse fail detector circuits with alarm contacts shall be provided for all D.C. fuses.

**3.8. Indicating Lamps**

The indicating lamp shall be of panel mounting, LED type and capable of clear status indication under the normal room illumination. The lamp covers shall be preferably screwed type, unbreakable and moulded from heat resistant material.

**3.9. Blocking Diode**

Blocking diode, wherever required, with full redundancy shall be provided in the output circuit of each Charger to prevent current flow from the D.C. Battery into the Charger.

**3.10. Annunciation System**

Visual indications through indicating lamps/LEDs or annunciation facia shall be provided in all Chargers for the following:

- i. A.C. supply failure
- ii. Rectifier fuse failure

- iii. Surge circuit fuse failure
- iv. Filter fuse failure
- v. Load limiter operated
- vi. Input AC MCCB trip
- vii. Output DC MCCB trip
- viii. Battery on Boost
- ix. Load-side DC under-voltage & over-voltage alarm
- x. Battery side DC over-voltage alarm
- xi. AC available – Battery discharge (Mains available battery discharge) alarm
- xii. Potential free NO contacts shall be provided for following remote alarms:
  - a) Battery on boost
  - b) Charger trouble (this being a group alarm initiated by any of the faults other than 'Battery on Boost')

**3.11. Name Plates and Marking**

The nameplates shall be made of non-rusting metal/3 ply Lamicoid and shall have black background with white engraved letters and secured by screws. These shall be provided near top edge on the front as well as on rear side of Charger. Nameplates with full and clear inscriptions shall also be provided on and inside the panels for identification of various equipment.

- 3.12.** Detailed dimensional drawings, commissioning and operating instructions and Test Certificates of the manufacturer shall be supplied with the equipment.

**3.12.1. CONSTRUCTION**

- 3.13.** The Chargers shall be indoor, floor mounted, self-supporting sheet metal enclosed cubicle type. The Contractor shall supply all necessary base frames, anchor bolts and hardware. The Charger shall be fabricated using cold rolled sheet steel not less than 1.6 mm thick. The panel frame shall be fabricated using cold rolled sheet steel of thickness not less than 2.0 mm. Removable un-drilled gland plates of at least 3.0 mm sheet steel and lugs for all cables shall be supplied by the Contractor. The lugs for cables shall be made of electrolytic copper with tin plating. Cable sizes shall be advised to the Contractor at a later date for provision of suitable lugs and gland plates. Ventilating louvers shall be backed with fine brass wire mesh. All doors and covers shall be fitted with nitrile/neoprene/PU rubber gaskets. The Chargers shall have hinged double leaf doors provided on front and/or backside for adequate access to the Charger internals. All the Charger cubicle doors shall be properly earthed. The degree of protection of Charger enclosure shall be at least IP-42. The construction shall meet the requirements of IS 6619. All equipment mounted in the cabinet shall be provided with individual labels with equipment designation engraved.

- 3.14.** In case of outdoor mounting, the charger shall be provided with double doors on both front & back and shall pass IP-42 requirement with one door open on both sides. The enclosure shall be provided with a canopy.

- 3.15.** The layout of Charger components shall be such that their heat losses do not give rise to excessive temperature within the Charger panel. Location of the electronic modules will be such that temperature rise, in no case, will exceed 10°C over ambient air temperature outside the Charger.

- 3.16.** Each Charger panel shall be provided with an illuminating lamp (CFL or tube-light) and one 5 Amp. socket. Switches and fuses shall be provided separately for each of the above.



**3.17.** Locking facilities shall be provided as following:

- a) For locking Float/Boost selector switch in the float position only.
- b) The Charger enclosure door shall have provision for padlocks. Padlocking arrangement shall allow ready insertion of the padlock shackle but shall not permit excessive movement of the locked parts with the padlock in position.

#### **4.6 WIRING**

**3.17.1.** Each Charger shall be furnished completely wired upto power cable lugs and terminal blocks, ready for external connection. The power wiring shall be carried out with 1.1 kV grade PVC insulated cables conforming to IS:1554 (Part-I). The control wiring shall be of 1.1kV grade PVC insulated stranded copper conductors of 1.5 sq.mm. minimum, conforming to IS:694. Control wiring terminating at electronic cards shall not be less than 0.75 sq. mm. Control terminal shall be suitable for connecting two wires of 1.5 sq.mm. stranded copper conductors. All terminals shall be numbered for ease of connections and identification. At least 20% spare terminals shall be provided for circuits.

**3.17.2.** Power and control wiring within panels shall be bundled separately. Any terminal or metal work which remains alive at greater than 415 V, when panel door is opened, shall be fully protected by shrouding.

An air clearance of at least ten (10) mm shall be maintained throughout all circuits, except low voltage electronic circuits, right upto the terminal lugs. Whenever this clearance is not available, the live parts should be insulated or shrouded.

#### **3.18. Painting**

Pre-treatment & phosphating with 7 tank process shall be provided as per IS: 6005. The phosphate coating shall be 'class-C' as specified in IS: 6005. Electrostatic powder painting with final shade – 692 (smoke grey) of IS: 5 shall be provided. The thickness shall not be less than 50 microns.

#### **3.19. PACKING & DISPATCH**

The equipment shall be dispatched securely packed in wooden crates suitable for handling during transit by rail/road so as to avoid any loss or damage during transit.

### **4. QUALITY ASSURANCE PLAN**

**4.1.** The vendor shall furnish the following information along with his bid; failing which the bid shall be liable for rejection. Information shall be separately given for individual type of material offered.

- i) The structure of Organization
- ii) The duties and representatives assigned to staff ensuring Quality of work
- iii) The system of purchasing, taking delivery and verification of materials
- iv) The system for ensuring quality of workmanship
- v) The quality assurance arrangements shall conform to the relevant requirement of ISO 9001 or ISO 9002 as applicable

- vi) Statement giving list of important raw materials/components, list of sub-suppliers, list of standards according to which the raw materials are tested.
- viii) List of manufacturing facilities available.
- ix) Level of automation achieved and list of areas where manual process exists.
- x) List of areas in manufacturing process, where stage inspections are normally carried out for quality control and details of such tests and inspections.
- xi) Lists of testing equipment available with the bidder for final testing of equipment specified and test plant limitation if any, vis-à-vis the type, special acceptance and routine tests specified in the relevant standards. These limitations shall be very clearly brought out in schedule of deviations from specified test requirements.

**4.2.** The contractor shall also submit following information after award of contract:

- i) Sub-suppliers of raw materials as well as bought out accessories & components. The equipment supplied shall adhere to the list of components submitted & as per type-tested equipment.
- ii) Type test certificates of the raw materials and bought out accessories as required by the owner.
- iii) Manufacturing Quality Plan (MQP) shall be submitted. The owner hold points for stage inspection shall be discussed between the owner and contractor at the time of award of contract before the MQP is finalized.

**4.3.** Makes of the following components (not restricted to) shall be subject to owner's approval.

- i) Relays
- ii) Instruments
- iii) SCR/IGBT
- iv) Diodes
- v) Annunciator

## **5. TESTS**

Battery chargers including the components shall confirm to all type tests including heat run test as per relevant Indian standards. Performance test on the chargers as per specification shall also be carried out on each charger.

### **5.1. TYPE TESTS**

**5.1.1.** Following type tests, in addition to the requirement of IS : 4540, should have been carried out on each rating and type of Battery Charger for which reports are to be submitted.

- i. Complete physical examination.
- ii. Temperature rise test at full load (at highest voltage & highest current).
- iii. Insulation resistance test.

- iv. High voltage (power frequency) test on power and control circuits except low voltage electronic circuits.
- v. Ripple content test at
- vi. No load
- vii. Half load
- viii. Full load
- ix. Automatic voltage regulator operation test at specified A.C. supply variations at
  - a) No load
  - b) Half load
  - c) Full load
- x. Load limiter operation test
- xi. Short circuit test at full load and at no load for sustained short circuit of 1-minute minimum shall be carried out. The charger shall not trip, no fuse shall blow and charger current shall be limited to 150% of the rated current.
- xii. Efficiency and power factor measurement.
- xiii. **Environmental Tests**  
 Steady state performance tests (clause 7.2.2 (f) and (g)) shall be carried out before and after the following tests.
  - i) Dry heat, Damp Heat, Vibration, Low temperature, Transportation, shock as per IS : 9000.
  - ii) Degree of protection test (IP-42).
- xiv. Rectifier transformer – As per IS 4540.

**5.1.2.** If type tests are carried out against the contract, minimum 15 days notice shall be given by the contractor. The contractor shall obtain the owner's approval for the type test procedure before conducting the type test. The type test procedure shall clearly specify the test set-up, instruments to be used, procedure, acceptance norms, recording of different parameters, interval of recording, precautions to be taken etc. for the type tests to be carried out.

**5.1.3.** In case the contractor has carried out the type tests within last five years as on the date of bid opening, he may submit the type test reports from NABL accredited laboratory to the owner for waiver of conductance of such type tests. These reports should be for the tests conducted on the equipment with identical design to that proposed to be supplied under this contract. The owner reserves the right for conducting any or all of the specified type tests under this contract.

**5.2. ROUTINE TESTS :**

**5.2.1.** Following routine tests shall be carried out on all Rectifier transformers in addition to tests required as per IS-4540.

- a) Insulation resistance test.
- b) High voltage (power frequency) test.

**5.2.2.** Following routine tests shall be carried out on all Battery Chargers in addition to tests required as per IS-4540 :

- a) Complete physical examination.

- b) Short circuit test at full load and at no load for sustained short circuit of 1-minute minimum shall be carried out. The charger shall not trip, no fuse shall blow and charger current shall be limited to 150% of the rated current.
- c) Insulation resistance test.
- d) High voltage (power frequency) test.
- e) Ripple content test at
  - i) No load
  - ii) Half load
  - iii) Full load
- f) Automatic voltage regulator operation test at specified A.C. supply variations at
  - i) No load
  - ii) Half load
  - iii) Full load
- g) Load limiter operation test
- h) Checking of proper operation of annunciation system.
- i) Dynamic response test Overshoot/Undershoot in output voltage of the charger as a result of sudden change in load from 100% to 20 % and 20% to 100% shall be measured.
- j) Soak Test - All electronic modules shall be subjected to continuous operation for a minimum period of 72 hours. During last 48 hours, the ambient temperature shall be maintained at 50 deg. C. The manufacturer shall submit the record of carrying out this test to the owner's engineer at the time of inspection.
- k) The charger shall be checked for gasketing arrangement as per drawing.

**5.2.3.** Following routine tests shall be carried out on annunciation system.

- a) Soak test shall be carried out as per Cl. 7.2.2 (j).

**5.3. ACCEPTANCE TESTS:**

**5.3.1.** Following acceptance tests and checks shall be carried out by the owner at the manufacturer's works:

- a) Complete physical examination.
- b) Checking of proper operation of annunciation system.
- c) Temperature rise test at full load.
- d) Insulation resistance test.
- e) Automatic voltage regulator operation.
- f) Load limiter operation.
- g) Dynamic response test.

h) Ripple content test

**5.3.2.** Overshoot/Undershoot in output voltage of the Charger as a result of sudden change in load from 100% to 20% and 20% to 100% shall be measured with the Batteries connected/disconnected. Output voltage of the Charger connected with Battery shall be within 90 % to 110 % of the voltage setting in above conditions and shall return to, and remain, within the limits specified in clause 3.1 (d) in less than 2 seconds.

**5.3.3.** The Contractor shall furnish for inspection, the type and routine tests certificates for Chokes and transformer whenever required by the Employer.

## **6. GUARANTEE**

The battery charger shall be guaranteed for a period of 24 months from the date of commissioning.

## **II. 30 VOLT 100 AH LEAD ACID BATTERY**

### **Part A : 30 Volt 100 Ampere-Hour Lead Acid stationary Battery**

#### **1. SCOPE**

This specification covers 30 Volt 100 Ampere-Hour Lead Acid stationary Battery, for use at 33/11KV substations for feeding auxiliary supply to Switchgear equipment at the time of interruption in mains supply. The battery is to be supplied along with wooden stand/rack as per description given below. Specifications of battery rack are indicated separately.

#### **2. APPLICABLE STANDARDS**

The cells of Lead Acid Battery shall conform to the requirements of IS 1651: 1991 with latest amendment thereof.

#### **3. STANDARD RATINGS**

The standards rating for 30 Volt Lead Acid Battery shall be 100 AH.

#### **4. CELL VOLTAGE**

The nominal voltage of a single cell shall be 2.1 to 2.2 Volts.

#### **5. CAPACITY AT ROOM TEMPERATURE**

The battery shall comprise of 15 cells with capacity not less than 100 AH at 10-hour rate of discharge to end voltage of 1.85 Volts per cell at room temperature not exceeding 32 degree C.

#### **6. GENERAL DESCRIPTION**

Cells shall be supplied in glass containers having ample space provided below the plate for accumulation of deposit. The glass containers shall be sufficiently robust, transparent and free from flaws. The bidder may also quote for battery with hard rubber containers, which shall conform to IS 1146: 1981.

Lead acid battery, comprising of closed type cells shall be complete with plante / tubular type positive plate assemblies, glass boxes, lids, micro porous plastic separators, polystyrene dowels and buffers, inter cell connectors and bolts & nuts. The battery shall be complete with (i) inter row connectors and bolts & nuts, acid jars and packing case, (ii) stands (iii) stand insulators (iv) cable sockets for end and tapping connections.

The sulphuric acid and water used for the preparation and maintenance of electrolyte shall conform to IS 266: 1977 and IS 1069: 1964 respectively.

The separators used shall be either wooden or synthetic. The wooden separators when used shall conform to IS 652:1960 and the synthetic separators to IS 6071: 1986.

The venting device shall be of anti-splash type with more than one exit hole and shall allow the gases to escape freely but shall effectively prevent acid particles or spray from coming out.

A suitable electrolyte level indicator indicating lower and upper limits shall be fitted to facilitate checking of electrolyte level in opaque containers. The materials used shall be acid proof and shall not deteriorate during service.

The manufacturer's identification shall be embossed/impressed on the connectors. Where it is not possible to bolt the cell terminals directly to assemble a battery, separate lead, copper or aluminium connectors of suitable size shall be provided to enable connection of the cells.

The material for bolts and nuts shall be brass. Bolts and nuts for connecting the cells shall be effectively lead-coated to prevent corrosion.

Open cells shall be provided with spray arrestors of adequate area over the plates. These may be of glass sheet at least 3 mm thick and shall be adequately supported.

## **7. MOUNTING STAND**

The cells shall be accommodated in double tier stand constructed of "SAL" wood and painted with 3 coats of acid proof paint. Necessary paint for this purpose shall be supplied. No metal fastenings shall be used. Stand should be self-supported and free from warp & twist. The assembled stand / rack should be suitable for bolting end to end to form continuous row. The stands shall be supported on insulators to obtain necessary insulation from earth and there shall be insulators between each cell and stand. The price of stand shall be included in the cost of the battery.

## **8. TERMINALS**

Separate terminals shall be provided for connecting load and charger leads to the battery terminals. All terminals shall be of M 12 size. The agency shall provide suitable copper lugs for use of the owner for connecting the load wiring.

## **9. ACCESSORIES**

The following accessories shall be supplied along with each battery and price for the same shall be included in the cost of the battery:-

1. One battery logbook
2. Two copies of printed instruction sheet
3. One no. cell testing voltmeter (3-0-3 volts) complete with leads

4. One no. floating hydrometer
5. One no. syringe hydrometer
6. One no. thermometer (0 to 100 degree C)with specific gravity correction scale
7. One set of suitable insulated spanners
8. One no. acid resisting funnel
9. One no. acid resisting jar
10. One pair of rubber gloves
11. Lead platted 2 nut – bolts and 2 washers set = 30 + 4 extra =34 Nos.
12. Cell insulators for mounting of cells = 15X4+6 extra = 66 Nos.
13. Rack insulator for mounting of battery rack = 8 Nos. minimum

**10. CHARGE RATE**

Fully discharged batteries should normally be recharged at 10 Amps. for 10 hours at room temperature. New batteries and old batteries at high temperatures may need more time. Trickle charge rate shall be about 50 to 100 mA,

**11. CELL DESIGNATION AND MARKING**

The practices indicated in relevant IS shall be followed for cell designation purpose.

The following information shall be indelibly and durably marked on the outside of the cell:-

1. Indicating the source of manufacture
2. Ah capacity at 10-hour rate
3. Upper and lower electrolyte level in case of transparent containers
4. Year of manufacture and
5. Country of origin
6. Each cell and battery may also be marked with the Standard Mark.

The polarity of the terminals shall be marked for identification. The positive terminal may be identified by "P" or (+) sign or Red colour mark and the negative terminal may be identified by "N" or (-) sign or a Blue colour mark. Terminal marking shall be permanent and non-deteriorating.

The battery shall be supplied with a warning plate located at conspicuous place specifying the use of "PARTICULAR ELECTROLYTE ONLY" (in block letters) & specifying the proper filling level of the electrolyte. Marking shall be permanent and non-deteriorating.

**12. TESTS**

The following tests shall be carried out in accordance with IS 1651:1991 with latest version thereof.

**13. TYPE TESTS**

1. Verification of constructional requirements
2. Verification of marking
3. Verification of dimensions
4. Test for capacity
5. Test for voltage during discharge
6. Ampere-hour and watt-hour efficiency tests

7. Test for loss of capacity on storage
8. Endurance test

#### **14. ACCEPTANCE TESTS**

The following shall constitute acceptance tests: -

1. Marking and packing
2. Verification of dimensions
3. Test for capacity, and
4. Test for voltage during discharge

#### **15. ROUTINE TESTS**

The battery shall be tested after manufacture as per the requirement of IS: 1651-1991 (with latest amendment, if any). Two copies of test certificates indicating the results obtained during the tests shall be submitted.

#### **16. MANUAL INSTRUCTIONS**

The manufacturer shall supply one copy of instruction manual for initial treatment and routine maintenance during service with each battery.

The following information shall be provided on the instruction cards:-

1. Designation of cell or battery
2. Ampere – Hour capacity
3. Nominal voltage
4. Manufacturer's instructions for filling, initial charging
5. Normal and finishing charging rates and
6. Maintenance instructions

#### **17. GUARANTEE PARTICULARS**

Expected life span of battery shall be minimum 10 years. Loss of capacity on storage of a fully charged battery stored for 28 days should not be more than 3%. Battery should be capable to bear under floating & over floating conditions.

The bidders shall essentially fill up the enclosed Schedule of Guaranteed Technical Particulars of Battery offered by him.

#### **18. PACKING**

The battery shall be suitably packed in wooden crates suitable for handling during transit by rail/road, and secured to avoid any loss or damage during transit.

### **Part B: Battery Charger**

#### **1. SCOPE**

This specification covers design, manufacturing, testing at manufacturer's works before dispatch and supply of 30 Volt 10 Ampere Single Phase Battery Charger required for charging of 30 Volt 100



Ampere-Hour Lead Acid Battery and for feeding auxiliary supply to Switchgear equipments at 33/11 kV substations.

**2. STANDARDS**

Unless otherwise specified, the equipment shall conform to the latest applicable Indian standards and in particular to the following standards:-

1	IS: 3895	Specification for Rectifier equipment's in general
2	IS: 13947(Part II)	Specification for MCB
3	IS: 1248	Indication instruments
4	IS: 2147	Degree of protection for cubicles
5	IS: 375	Specification for wiring
6	IS: 4540	Mono crystalline semiconductor rectifiers assemblies & equipment
7	IS: 6619	Safety code for semiconductor rectifier equipment
8	IS: 2026	Transformers
9	IS: 4237	General requirement for switchgear and control gear for voltage not exceeding 1000 Volts
10	IS: 4064	Air Break switches and fuse combination units
11	IS: 6005	Code of practice for phosphating of Iron & Steel
12	IS: 5	Colour for ready mix paints
13	IS: 5921	Printed circuit Board
14	IS: 249	Printed circuit Board
15	IS: 5578	Guide for making insulated conductor

The agency shall clearly state the standards to which the equipment offered by him conforms.

### **3. DRAWING AND LITERATURE**

The bidder shall furnish all such drawings, instruction manuals, descriptive literature etc., as may be necessary for the proper understanding of the functioning of the charger.

The write-up should include the following:-

1. Technical specification of the charger.
2. Detailed circuit description of the charger. It should also include the functions of various components, protection circuits/cards, and relays along with their individual brief write-ups/leaflets.
3. List of the main components of the charger.
4. Following details are to be clearly indicated in the circuit diagram:-
  - a. Make and Rating of components used
  - b. All the fuses should be numbered and individual rating should be indicated.

### **4. GENERAL DESCRIPTION**

The Charger shall be of simple design so as to ensure its reliable functioning and ease in maintenance/repairing. Complicated circuitry shall be avoided, as far as possible. The bidder shall indicate, as to how reliable functioning of the charger is achieved. He shall also indicate the quality control adopted for the reliable product.

The battery charging equipment shall comprise of a selenium/solid state silicon rectifier suitable for operation on 230/250 Volt Single Phase AC system. Associated transformer, regulatory resistance, switches etc. shall be accommodated in a sheet steel cubicle arranged for continuous load of 3 Amps. Adjustable from 0 to 3 Amps trickle charge of the battery and manual provision to operate at a higher voltage to recharge the battery of 100 AH capacity quickly at 10 Amp rate.

The equipment shall comprise of:-

1. AC mains switch/MCB 230/250 Volt Single Phase with fuses/MCB
2. Pilot lamp/LED type to indicate AC supply ON.
3. Ballast choke
4. Single Phase Double Wound Transformer for rectifiers
5. Main transformer single phase variac with rough and fine control to charge battery in steps of 6-12, 12-18, 18-24, 24-30, 30-36, 36-42 volts.
6. Full wave bridge connected plate/solid state silicon rectifier
7. Fuses for rectifier output
8. Moving Coil Ammeter 96-mm sq. flush mounting type (0-15 Amps.)
9. Moving Coil Voltmeter 96 mm sq flush mounting type (0-50 Volts)
10. Voltmeter fuses
11. DC ON/OFF switches with fuses.

The sheet steel cubicle of the rectifier unit shall also accommodate the switches for charge rate selection, incoming from battery and various apparatus for battery control.

The chargers should have in-built automatic input voltage stabilizer in the range of 180 volt to 275 volt to facilitate steady output voltage and current from the charger.

**5. CABINET**

The charger shall be enclosed in a cabinet made of sheet steel of not less than 1.5 mm thickness and should be suitable for mounting on a plane surface/floor with ventilation louvers on two sides and finish painted with synthetic enamel paint of white on inside and opeline green on outside. Two coat of zinc primer shall be applied before finishing synthetic enamel paint. The cabinet shall have vermin proof construction. The cabinet legs shall be of adequate height and strength and should provide minimum clearance of 100 mm from ground.

**6. FRONT PANEL MOUNTINGS**

The following provisions conforming to relevant ISS shall be made on the front panel:

1. Voltmeter to indicate battery/charger DC voltage
2. Voltmeter to indicate incoming AC voltage
3. Ammeter to indicate charging/load current
4. Indicating LEDs to indicate:-
  - a. Supply of power;
  - b. Charger on;
  - c. Input voltage less than 180 Volt
5. Audio/Visual alarm to indicate:-
  - a. Power failure;
  - b. Charger failure;
  - c. Battery disconnection/failure;
  - d. Battery reverse; and
  - e. DC under/Over voltage.

In case of failure of charger on fault, it should give buzzer as well as LED indication. However, the buzzer alarm should be provided with a reset switch. The indicating instruments shall be of class 1.0 accuracy

**7. TRANSFORMER**

The power transformer rectifier unit of the battery charger shall be designed for adequate VA rating but in any case it should not be less than 700 VA and should be rated for 300 V at factor of safety of 3. The heat dissipation and power control system should be designed with a factor of safety of 8. Rating of silicon diode should not be less than 15 A.

Please note, necessary documentary evidence, showing transformer rating of 700 VA along with test certificate from manufacturer, if bought-out, shall be enclosed, for approval of the owner.

**8. PROTECTION**

The charger should have built-in reverse polarity protection with indication lamp so as to protect the battery from high drains. The charger should also have MCB in the output circuit for protection from short circuits.

**9. LIGHT EMITTING DIODES**

For the purpose of indication LED indicators shall be provided.

**10. SWITCHES AND FUSES**

Control and instruments switches shall be of toggle type. All fuses shall be of HRC type and of English Electric/L&T make only.

**11. LABELS**

All front panel mounted equipment as well as the equipment mounted inside the cabinet shall be provided with individual labels with equipment designation engraved on aluminium plate (stickers are not acceptable).

**12. WIRING**

The charger shall be supplied completely wired ready for external connections at the terminal blocks. All the wiring shall be carried out with 1100 V Grade PVC insulated standard copper conductor of 2.5 Sq.mm. Colour coded wires should be used to facilitate easy tracing, as under :-

A. Single Phase AC Circuit:-

1. Red for Phase
2. Green for Earthling
3. Black for Neutral

B. D.C. Circuit:-

1. Red for Positive
2. Black for Negative

C. Control Wiring:- Gray for annunciation and other control circuits.

**13. FERRULES**

Engraved core identification ferules, marked to correspond with the wiring diagram shall be fitted at both ends of each wire.

**14. EARTHING TERMINALS**

The battery charger cabinet shall be provided with two separate suitable earthing terminals of good quality and adequate size.

**15. TESTING**

The manufacturers on each battery charger shall carry out the following tests and copy of the tests certificate for each charger shall be submitted:-

1. Checking of wiring and continuity of circuits and visual inspection
2. High voltage test on the equipment with accessories. (All equipment and wiring should be tested for with-standing the power frequency voltage of 2 KV r.m.s. for 20 seconds.)

3. Checking of charging current and load currents.
4. Checking of relays operation, alarm circuit operation, lamp indication, charger failure, mains failure, load fuse failure and annunciation (manufacturer's test certificate for the instruments shall also be furnished).
5. Regulation and Ripple tests.
6. Efficiency test.
7. Burn-out/Heat-run test (for 10 Hrs.)

**16. CIRCUIT DIAGRAM AND WRITE-UP**

It is desired that the complete schematic of the charger is provided on a permanently laminated/engraved plate of suitable thickness, which has to be bolted/riveted at the four corners on the inside face of rear door. In addition, one more plate of similar type and dimension shall be provided on the outside of the rear door providing guidelines and instructions for operation of the charger. The guidelines and schematic to be provided on the plates shall be as per our approval for which separate drawings shall furnish, after award of contract.

**17. TERMINALS**

Separate terminals shall be provided for connecting load and battery leads to the charger. All terminals shall be of M12 size. Suitable copper lugs for connecting the load wiring are to be provided.

It would be the bidder responsibility to prove the adequacy of its design by submitting all technical particulars and relevant graphs to show suitability of charger for supplying load on continuous basis.

**18. PRINTED CIRCUIT BOARD**

The printed circuit boards should be made out of glass fiber re-in forced epoxy boards and should be coated with suitable protective coating for protection against humidity and corrosion.

**19. POLARITY MARKING**

The polarity marking of the terminals shall be marked for identification. The positive terminal may be identified by "P" or (+) sign or red colour mark and the negative terminal may be identified by "N" or (-) or blue colour. Terminal marking shall be permanent and non-deteriorating.

**20. MANUAL OF INSTRUCTIONS**

The manufacturer shall supply a copy of the Instruction Manual for commissioning and initial testing of the charger and maintenance during service with every charger supplied.

**21. PACKING**The charger shall be securely packed in wooden crates suitable for handling during transit by rail/road so as to avoid any loss or damage during transit.

**11. LT upto (1100 V) XLPE Insulated**

**1.0 SCOPE:**

1.1 The scope of this specification covers the design, manufacture inspection and testing the finished ISI marked LT (1100 volts, 31/2 x25 Sq.mm to 400 Sq.mm stranded, compact aluminum conductor, with XLPE insulated, PVC inner sheathed, galvanized steel strip armored/unarmoured and overall PVC sheathed Black colour cable conforming to IS:7098 /88 with latest amendments and as per specification detailed.

**2.0 RATED VOLTAGE:**

2.1 The rated voltage of the cable shall be 1100 Volts AC with the highest system voltage of 1100 Volts between phases of the effectively earthed three-phase transmission system.

2.2 The cables shall be capable of operating continuously under the system frequency variation of  $\pm 3$  Hz, voltage variation of  $\pm 10\%$  and a combine d frequency – voltage variation of  $\pm 10\%$ .

**3.0 APPLICABLE STANDARDS:**

- i) Unless otherwise stipulated in the specifications, the latest version of the following Standards shall be applicable:  
 IS 7098 (Part 2)-Cross-linked Polyethylene insulation for Cables.  
 IS 8130-Conductors for insulated electrical cables and flexible cords.  
 IS 10810(series)-Methods of tests for cables.  
 IS 10418-Drums for electric cables.  
 IS 3975-Specification for mild steel wires, strips and tapes for armouring of cables.  
 IS 5831-Specification for PVC insulation sheath for electric cables.  
 IS 10462-Fictitious calculation method for determination of dimensions of protective coverings of cables Part 1 - Elastomeric and thermoplastic insulated cables.
- ii) The cables manufactured to any other International Standards like BSS, IEC or equivalent standards not less stringent than Indian Standards are also acceptable. In such cases the Manufacturer shall enclose a copy of the equivalent international standard, in English language.

**4.0 CONSTRUCTION:**

4.1 **Conductor:** - The cable conductor shall be made from stranded aluminum to form compact sector shaped conductor having resistance within the limits specified in IS:8130/1984 and any amendment thereof. The wires shall be laid up together with a suitable right hand lay. Stranded Class 2 – as per the IS:8 130 / IEC 60228/ BS 6360 standards.

4.2 **Insulation:** - The insulation shall be cross linked polyethylene applied by extrusion and shallbe steam (wet) cured as pre IS:7098(1)1988 and curing in hot water tank/bath is not accepted.:

<b>SI.No.</b>	<b>Properties</b>	<b>Requirements</b>
1.	Tensile Strength	12.5N/mm <sup>2</sup> , Min.
2.	Elongation to break	200 percent, Min
3.	Aging in air oven:	

	a) Treatment: Temperature: Duration:	135±3°C 7 days
	b) Tensile Strength variation:	±25 percent, Max
	c) Elongation variation:	±25 percent, Max
4.	Hot set: a) Treatment: Temperature: Time under load Mechanical stress	200±3°C 15 min 20N/cm <sup>2</sup>
	b) Elongation under load	175 percent, Max
	c) Permanent elongation (set) after cooling	15 percent, Max
5.	Shrinkage: a) Treatment: Temperature Duration	130±3°C 1 hour
	b) Shrinkage	4 percent, Max
6.	Water absorption (Gravimetric): a) Treatment: Temperature: Duration	85±2°C 14 days
	b) Water absorbed	1 mg/cm <sup>2</sup> , Max
7.	Volume Resistivity a) at 27°C	1x10 <sup>14</sup> ohm-cm, Min
	b) at 70°C	1x10 <sup>13</sup> ohm-cm, Min
8	Thermal Resistivity	350 degrees C cm/W
9	Powerfactoratmaximumconductor temperature	0.008
10	Dielectric strength	22 kV/mm

**4.3.1** The XLPE insulation should be suitable for specified 1.1 KV system voltage.

**4.3.2** The manufacturing process shall ensure that insulations shall be free from voids.

**4.3.3** The insulation shall withstand mechanical and thermal stresses under steady state and transient operating conditions.

**4.3.4** The insulation of the cable shall be high stranded quality, specified in IS:7098 (Part-II/1985). Withstand continuous conductor temperature of 90 deg C, which means higher continuous rated current carrying capacity.

**4.3.5** The cables can operate even at conductor temperature of 130 deg C continuously and 250 deg C during a Short Circuit condition

**4.4 SHEATH :**

The sheath shall be suitable to withstand the site conditions and the desired temperature. It should be of adequate thickness, consistent quality and free from all defects. The PVC sheath shall be extruded as per IS:7098 (Part – I/1988). IEC:60502 Part– I,BS:6622, LSOH to BS:7835.

**4.5 ARMOUR :**

Armoring shall be applied over the inner sheath with single galvanized steel complying with the requirements of IS:3975/1979. The dimensions of the galvanized strip shall be as specified in table 4 of the IS:7098/Part-I/1988. The armour wire shall be applied as closely as practicable. The direction of the lay of the armour shall be left hand. The joints in armour wire shall be made by brazing or welding and the surface irregularities shall be removed. A joint in any wire shall be atleast 300mm from the nearest joint in any other armour wire in the complete cable and shall be as per IS:7098 Part 1, IS: 3975.

The cable without armoring shall also be accepted of type detailed in price schedule.

**4.6 OUTER SHEATH :** Extruded PVC ST2, outer sheath as per IS:5831/1984, IS:7098

Part 1, IEC:60502 Part – 1, BS:6622, LSOH to BS:78 35. shall be applied over armoring with suitable additives to prevent attack by rodents and termites. Outer sheathing shall be designed to offer high degree of mechanical protection and shall also be heat, oils, chemicals, abrasion and weather resistant. Common acids, alkalis, saline solutions etc., shall not have adverse effects on the PVC sheathing material used.

4.7 The cables should be suitable for use in solidly earthed system.

4.8 The power cables shall be manufactured to the highest quality, best workmanship with scientific material management and quality control. The Manufacturer shall furnish the quality plan, giving in detail the quality control procedure / management system.

4.9 The cable shall be suitable for laying in covered trenches and/or buried underground to meet the outdoor application purposes.

4.10 **The parameters of the LT power cables to be supplied shall be as specified below**

Nom. cross sectional area (Sq.mm)	Nom. Thickness of XLPE Insulation mm main core	Armoured			Max.DC Conductor Resistance at 20°C (ohm/km)	AC current rating	
		Nom. Steel Armour size (mm)	Approx. Overall dia. (mm)	Approx. Weight (kg/km)		In air (amps)	In Grpund (amps)
25	0.90	4 X 0.8	22.8	821.0	1.200	95	97
35	0.90	4 X 0.8	24.9	961.0	0.868	117	116
50	1.00	4 X 0.8	28.1	1195.0	0.641	140	134
70	1.10	4 X 0.8	33.0	1569.0	0.443	176	167
95	1.10	4 X 0.8	35.8	1903.0	0.320	221	199
120	1.20	4 X 0.8	39.0	2303.0	0.253	258	227
150	1.40	4 X 0.8	42.9	2720.0	0.206	294	255
185	1.60	4 X 0.8	47.5	3276.0	0.164	339	287
240	1.70	4 X 0.8	52.7	4048.0	0.125	402	333
300	1.80	4 X 0.8	58.4	4872.0	0.100	461	375
400	2.00	4 X 0.8	65.6	6101.0	0.0778	542	426

4.11 The short circuit current of the LT cable to be as specified below

Sq.mm of LT Cable	Short Circuit Current(KA)
25	2.420
35	3.370
50	4.790
70	6.680



95	9.030
120	11.400
150	14.200
185	17.500
240	22.600
300	28.200
400	37.600

**5.0 SYSTEM DETAILS:**

**General Technical particulars**

Nominal system voltage (rms) (U)	0.44KV
Highest system voltage (rms) (U <sub>m</sub> )	1.1 KV
Number of Phase	3
Frequency	50Hz
Variation in Frequency	+/- 3%
Type of Earthing	Solidly Earthed
Total relay & circuit breaker Operating time	15 – 20 cycles

**6.0 CLIMATIC CONDITIONS:**

(a) Maximum ambient air temperature (in shade)	45 <sup>0</sup>	C
(b) Maximum ambient air temperature (under sun)	50 <sup>0</sup>	C
(c) Maximum daily average ambient air temperature	35 <sup>0</sup>	C
(d) Maximum yearly average ambient air temperature	30 <sup>0</sup>	C
(e) Maximum humidity	100%	
(f) Altitude above M.S.L.	Up to 1000M	
(g) Average No. of thunder storm days per annum	50	
(h) Average No. of dust storm days per annum	Occasional	
(i) Average No. of rainy days / annum	90	
(j) Average Annual Rain fall	925mm	
(k) Normal tropical monsoon period	4 months	
(l) Maximum wind pressure	150 kg/Sq.M	

**7.0 DESIGN CRITERIA:**

- i. The cables that are covered in these specifications are intended for use outdoor , under the climatic conditions and installation conditions described in the technical specification.
- ii. For continuous operation of the cables, at specified rating, the maximum conductor temperature shall be limited to the permissible value as per the relevant standard, generally not exceeding 90°C under normal operation and 250°C under short – circuit conditions.
- iii. The cables in service will be subject to daily load cycles, of two peaks during a day; morning peak and evening peak, with around 25% to 50% loading during the nights.
- iv. The materials used for outer sheaths shall be resistant to oils, acids and alkalis.
- v. The cables shall have the mechanical strength required, during handling and laying.

- vi. The cables shall be designed to withstand the thermo-mechanical forces and electrical stresses during normal operation and transient conditions.
- vii. The cables shall be designed to have a minimum useful life span of Thirty-five years.
- viii. The detailed design drawings shall be submitted along with Purchase order.

**8.0 MANUFACTURE PROCESS:**

Cross-linking of the insulation materials (pre compounded polyethylene) shall be conforming to IS: 7098 (Part – II) and the proof of purchase of the above insulating material shall be submitted and is to be offered for stage inspection..

**9.0 MATERIALS:**

- 9.1 **Conductor:** -The conductor shall be of stranded construction. The material for conductor shall consist of the plain aluminum of H2 or H4 grade as per clause – 3 of IS 8130/ 1984.
- 9.2 The minimum number of wires shall be 53 for circular compacted 400 sq. mm aluminum conductor as per table – 2 of IS 8130/ 1984.

**10.0 CORE IDENTIFICATION:**

- 10.1. The core identification for 31/2 core cables shall be provided, by suitable means, like, by application of individual colour or colored stripes, or by numerals or by printing on the cores as per clause 13 of IS: 7098 - Part 2
- 10.2. For identification of different coloring of XLPE Insulation, or by using colored strips, red, yellow and blue colors respectively shall be used to identify the phase conductors.

**11.0 LAYING UP OF CORES:**

The cores shall be laid together with a suitable right hand lay. The interstices at the center shall be filled with a non- hygroscopic material.

**12.0 INNER SHEATH (COMMON COVERING):**

- 12.1 The laid up cores shall be provided with inner sheath applied either by extrusion. It shall be ensured that the shape is as circular as possible. The inner sheath shall be so applied that it fits closely on the laid up cores and it shall be possible to remove it without damage to the insulation.

- 12.2 The thickness of the inner sheath (common covering) shall be given as follows:

<b>CALCULATED DIAMETER IN MM OVER LAID UP CORES [REF IS 10462 (PART 1)]</b>		<b>THICKNESS OF INNER SHEATH (Min) mm</b>
Over	Up to and including	
–	25	0.3
25	35	0.4
35	45	0.5
45	55	0.6
55	–	0.7

- 12.3 When one or more layers of binder tapes are applied over the laid up cores, the thickness of such tapes shall not be construed as a part of inner sheath.

**13.0 ARMOURING:**

- 13.1 Armouring shall be single strip steel wire applied over the inner sheath as closely as practicable. The direction of the lay of the armour shall be left hand.
- 13.2 The armour shall consist of galvanized strip steel. The dimensions of the galvanized steelwires shall be 4 X 0.8 mm (Nominal)
- 13.3 The joints in the armour strip shall be made by brazing or welding and the surface irregularities shall be removed. A joint in the wire shall be at least 300-mm from the nearest joint in any other wire in the complete cable.
- 13.4 Manufacturers shall furnish the calculation / data sheet for the short circuit carrying capability of the Armour.

**14.0 OUTER SHEATH:**

- 14.4 The outer sheath shall be applied by extrusion. It shall be applied over the armouring shall consist of poly-vinyl chloride (PVC) compound, conforming to the requirements of type ST-2 of IS 5831. Suitable additives shall be added to give anti termite protection.
- 14.5 The minimum thickness of the PVC outer sheath shall be as per IS:10462 and as detailed.

Calculated diameter under the outer sheath [IS 10462 Part 1] – mm		Nominal thickness of the outer sheath (ts) - mm
Over	Up to and including	
–	15	1.24
15	25	1.40
25	35	1.56
35	40	1.72
40	45	1.88
45	50	2.04
50	55	2.20
55	60	2.36
60	65	2.52
65	70	2.68
70	75	2.84
75	–	3.0

**14.6 IDENTIFICATION:**

The outer sheath shall have the following information embossed or indented on it; ISI marking, the manufacturer's name or trade mark, the voltage grade, the year of manufacture and the letters "DDUGJY, Name of Employer" The identification shall repeat every 300/350mm along the length of the cable. Outer sheath of cable shall be black in permanent colour.

**15.0 INSPECTION AND QUALITY CONTROL:**

The Manufacturer shall furnish a complete and detailed quality plan for the manufacturing process of the cable. All raw materials shall conform to relevant applicable standards and tested for compliance to quality and requirement. During the manufacturing process, at all stages, inspections shall be made to check the physical and dimensional parameters, for verification to compliance to the standards. The Manufacturer shall arrange, for inspection by the purchaser, during manufacture with one month

advance notice for verifying the various stage inspections as specified in the quality assurance plan enclosed to verify the quality control process of the Manufacturer.

**16.0 TYPE TESTS:**

Type test certificates from Accredited NABL Testing Laboratories for 1.1 kV XLPE, shall be submitted along with Purchase order. The Type Tests should have been conducted not later than 5 years as on the date of supply.

- 16.1 Stage wise Inspection: The Manufacturer shall offer the stage wise inspection as detailed in the in the quality assurance plan
- 16.2 All acceptance tests shall be conducted in the presence of the Employer’s representative.
- 16.3 The supplier shall give 10 days advance notice for inspections, and witnessing of tests by the Employer representative.
- 16.4 The following type tests shall be conducted on the cable.

Sl. No.	Test	Requirement	Test method Ref Part no of IS: 10810
a)	Tests on conductor		
	i) Tensile test	IS:8130	2
	ii) Wrapping test	IS:8130	3
	iii) Resistance test	IS:8130	4
b)	Tests for armoured wires and strips	Clause 15.2 & IS:3975	36 to 42
c)	Test for thickness of insulation and sheath	Clause 4.3, 14.2 & 16.2	6
d)	Physical tests for insulation:	Clause 4.2	
	i) Tensile strength and elongation at break		7
	ii) Aging in air oven		11
	iii) Hot test		30
	iv) Shrinkage test		12
	v) Water absorption (gravimetric)		33
e)	Physical tests for outer sheath	IS: 5831	
	i) Tensile strength and elongation at break		7
	ii) Aging in air oven		11
	iii) Shrinkage test		12
	iv) Hot deformation		15
f)	High voltage test	Clause 22.7	45
g)	Flammability test	Clause 22.8	53

**17.0 ACCEPTANCE TEST:**

- 17.1 The sampling plan for acceptance test shall be as per IS 7098 part -II, Appendix 'A'.
- 17.2 The following shall constitute the acceptance test.
  - a. Tensile test for aluminum.
  - b. Wrapping test for aluminum.

- c. Conductor resistance test.
- d. Test for thickness of insulation.
  - (i) Test for thickness of inner and outer sheath.
  - (ii) Hot-set test for insulation.
  - (iii) Tensile strength and elongation at break test for insulation and outer sheath.
  - (iv) High voltage test.
  - (v) Insulation resistance (volume resistivity) test.

**18.0 ROUTINE TEST:**

The following shall constitute routine tests:

- o Conductor resistance test.
- o High voltage test.

**19.0 DETAILS OF TESTS:**

19.1 Unless otherwise mentioned in this specification, the tests shall be carried out in accordance with appropriate part of IS: 10810.

19.2 High Voltage Test at room temperature:  
 The cables shall withstand a voltage of 3KV AC (rms) at a frequency of 40 to 60 Hz or an AC voltage of 7.2kV , between conductors and between conductors and ECC ( if any) for a period of 5 minutes each test connection.

19.3 Flammability test: Period of burning after removal of the flame shall not exceed 60 seconds and the unaffected (uncharred) portion from the lower edge of the top clamp shall be at least 50-mm.

Employer reserves the right to select a random sample of 1.1 kV UG cable from the Manufacturer's end which are ready to dispatch and also ongoing cable laying works and the same samples will be sent to any testing laboratory as desired by Employer. If the testing results are found to be not satisfactory Employer reserves the right to reject the entire batch of cable received and insists for replacement of material free of cost. The decision of Employer in this regard is final.

**20.0 PACKING:**

20.1 The cables, as per specified delivery lengths, shall be securely wound /packed in non-returnable wooden drums, capable of withstanding rough handling during transport by Rail, Road, etc. The packing should withstand storage conditions in open yards. The cable drums shall conform to IS 10418-1982 or equivalent standard. The dimensional drawings of wooden drums shall be furnished with the Purchase order. The drum shall be provided with circumferential lagging of strong wooden planks. The end of the cable shall be sealed with good quality heat shrink sealing caps. The sufficiently required additional sealing caps shall be supplied for use of testing during laying and jointing at site and to seal spare lengths of cable. The packing should be able to withstand the rigorous of transport. The following information in bold letters in English shall be painted on the flanges.

- a. Name & Address of the manufacturer, Trade name/Trade mark/Brand
- b. ISI Marking
- c. Size of cable (Cross section) rated voltage, standard, insulation, cable code, drum No., and year of manufacture.
- d. Length of cables (Meters)
- e. Direction of rolling
  - i) Net weight (in Kg)
  - ii) Gross weight (in Kg)
  - iii) Owners purchase order reference.

**21.0 SEALING OF CABLE ENDS ON DRUMS:**

21.1 The cable ends shall be sealed properly so that ingress of moisture is completely prevented. The individual core endings shall be sealed effectively with water resistant compound applied over the core

and provided with a heat shrinkable or push-on or Tapex or cold shrinkable type cap of sufficient length with adequate cushion space so that the conductor does not puncture the cap in case of movement of the core during unwinding or laying. Before sealing, the semi conducting layer on the cores may be removed for about 2 mm at each end, to facilitate checking the insulation resistance from one end, without removing the sealing cap at the other end.

- 21.2 The three cores should have an overall heat shrinkable or push-on or Tapex or cold shrinkable type cap with adequate end clearance, and sufficient cushioning to prevent puncturing of the overall sealing cap due to stretching of the cores. The sealing cap shall have sufficient mechanical strength and shall prevent ingress of moisture into the cable. The ends of single core cables shall also be sealed on the same lines to prevent entry of moisture.

**22.0 CABLE LENGTHS:**

The cables shall be supplied in continuous lengths of 500 m or more with 5% tolerance and cable shall on the wooden drums only.

**23.0 QUANTITY TOLERANCE:**

A +3% tolerance shall be allowed on the ordered quantity including 300-m cable as spare.

**24.0 MARKING:**

- 24.1 The packed cable drum shall carry the following information, clearly painted or stenciled.

- a. The letters 'DDUGJY, Name of Employer'
- b. Reference to Standard and ISI mark.
- c. Manufacturer's Name or trade mark.
- d. Type of cable & voltage grade.
- e. Number of cores.
- f. Nominal cross-sectional area of conductor.
- g. Cable code.
- h. Length of cable on the drum.
- i. Direction of rotation.
- j. Gross weight.
- k. Country of Manufacture.
- l. Year of Manufacture.
- m. Purchase order and date.
- n. Address of consignee.

**25.0 GUARANTEED TECHNICAL PARTICULARS:**

The manufacturer, shall furnish the guaranteed technical particulars of the cable offered in the GTP format provided.

**26.0 DRAWING & LITERATURE:**

- (i) The following shall be furnished along with the tender  
 Cross sectional drawings of the cables, giving dimensional details.  
 An illustrated literature on the cable, giving technical information, on current ratings, cable constants, short circuit ratings, de rating factors for different types of installation, packing date, weights and other relevant information.

- 27.0** GUARANTEE: The cable manufactured shall be guaranteed for the period of 18 months from the date of receipt at stores.

- 28.0** The Manufacturer shall furnish a copy of valid BIS licence for ISI marking without which the cable shall not be accepted.

**GUARANTEED TECHNICAL PARTICULARS FOR 1.1 KV**

	<b>Manufacturer's Name</b>		
	<b>Class of Power Cable</b>		
1	Name of the Manufacturer and country of origin		
2	Country of Manufacture		
3	Type of cable / cable code		
4	Applicable standard		
5	Voltage		
	a. Rated Nominal voltage		
	b) Rated Maximum voltage		
6	Suitability for :		
	a. Earthed system		
7	<b>Conductor</b>		
	a) Nominal cross section (sq.mm)		
	b) Material		
	c) Shape		
	d) Diameter of conductor (mm)		
	e) Number of wires per conductor (Nos.)		
	f) Nominal diameter of wire in conductor (mm)		
8	<b>Insulation XLPE</b>		
	a) Curing process (furnish details separately)		
	b) Material/Composition		
	c) Dia over insulation		
	i. Nominal (mm)		
	ii. Average (mm)		
	iii. Minimum (mm)		
9	<b>Inner sheath</b>		
	a) Type / composition		
	b) Material		
	d) Tolerance on thickness		
	e) Diameter of cable over sheath (mm)		
10	<b>Armouring</b>		
	a) Material		
	b) Dia of wire		
	Nom. (mm)		
	Min. (mm)		

	<b>Outer sheath</b>		
11	a) Type / composition		
	b) Material		
	c) Nominal thickness		
	d) Tolerance on thickness		
	e) Diameter of cable over sheath (mm)		
	<b>Anti-thermite treatment to outer sheath</b>		
12	a) Material		
	External overall dia of cable		
	Short circuit rating of conductor 90 deg. C operating temperature for 1 Sec.		
13	Minimum cable bending radius (in terms of cable diameter)		
14	Permissible maximum tension		
15	Continuous current rating under specified insulation conditions at conductor temperature of 65 deg. C and 90 deg. C.		
16	Ground Temperature 30 deg. C		
17	Thermal resistivity of soil 150 deg. C CM/W		
18	Depth of laying 200 mm		
19	Ambient Air temperature 40 deg. C		
20	No. of circuits 1 OR 2		
21	Spacing between two circuits		
22	Formation		
23	Maximum permissible conductor temperature for continuous operation under specified installation conditions (deg. C)		
24	Conductor temperature at rated current (deg. C)		
25	Basic impulse level at conductor temperature of 90 deg. C (KV)		
26	Impulse wave shape		
27	Power frequency with stand voltage (KV)		
28	Tan Delta at 50 Hz (at U.KV and 90 (-5/+10) deg. C		
29	Sheath voltage at max. load		
30	Withstand voltage of sheath on spark test		
31	Permissible short circuit current ratings of conductor		
	i) 0.1 Sec KA		
	ii) 0.2 Sec KA		
	iii) 0.5 Sec KA		



	iv) 1.0 Sec KA		
32	<b>Conductor resistance DC &amp; AC</b>		
	a) at 20 deg. C (d.c)/A.C. ohm/KM		
	b) at 90 deg. C (d.c)/A.C. ohm/KM		
	c) at 105 deg. C (d.c)/A.C. ohm/KM over load temp) a.c. (ohm)		
33	<b>Equivalent star resistance at 50 Hz of 3 phase current</b>		
	a) at 20 deg. C (d.c)/A.C. ohm/KM		
	b) at 90 deg. C (d.c)/A.C. ohm/KM		
	c) at 10% continuous overload temperature (ohm/KM)		
34	<b>Star reactance at 50 hz (ohm/KM)</b>		
	Approximate impedance at 50 hz per KM		
	a. at 20 deg. C ohm/KM		
	b. at 90 deg. C ohm/KM		
	c. at 10% continuous overload temperature (ohm/KM)		
35	Self-electrostatic capacitance per phase (Micro farad/KM)		
36	Maximum power factor at charging KVA of cables when laid direct in ground at normal voltage & frequency		
	a) at ambient Temperature		
	b) at Maximum conductor Temperature		
37	<b>Impedance</b>		
	a) Positive and negative sequence impedance 37 (ohm/KM)		
	b) Zero sequence impedance (ohm/KM)		
	c) Zero sequence data		
38	<b>Series reactance / Resistance</b>		
	a) Series resistance (ohm/KM)		
	Series reactance (ohm/KM)		
	Shunt capacitive reactance (ohm/KM)		
39	Sheath resistance at 20 deg. C ohm/KM		
40	Surge impedance of cable (ohm/KM)		
41	IR value at ambient temperature per KM		
	Maximum magnitude of partial discharge at 1.5 U.o		

	At Ambient Temperature (Po)		
	At High Temperature (Po)		
	Losses per Km.		
	NOTE : (i) Cable Conductor size 400 sq. mm		
	a) Total 3 phase dielectric loss		
	i. One circuit alive Kw/KM		
	ii. Both circuits alive KW/KM on each circuit		
	b) Total 3 phase resistive loss		
	i. One circuit alive Kw/KM		
	ii. Both circuits alive KW/KM on each circuit		
	c) Total 3 phase sheath / screen loss		
	i. One circuit alive Kw/KM		
	ii. Both circuits alive load KW/KM on each circuit		
42	d) Other losses due to reinforcement		
43	One circuit alive KW/KM		
	Both circuits alive KW/KM on each circuit		
	Total losses		
44	i. One circuit alive KW/KM		
	ii. Both circuits alive KW/KM		
	Charging current at rated voltage per Km (Amps)		
45	Short circuit capacity of conductor for one second at 90 deg. C prior to short circuit and 250 deg. C during short circuit (KA)		
	Screening factor of cable for calculating interference on control and communication cables :		
	Approximate value of attenuation of carrier current signals operating over a frequency range		
46	i. 50 KC/s- dB/KM		
	ii. 100 KC/s- dB/KM		
	iii. 150 KC/s- dB/KM		
	iv. 200 KC/s- dB/KM		
	<b>Shipping weight and size of cable drum</b>		
	a) Size of Drum		
47	i. Dia of Drum (M)		
	ii. Width of Drum (M)		
	iii. Gross Weight (Kgs)		
	iv. Length of cable per Drum(M)		
	v. Weight of Cable (Kg/M)		

**Current Rating Factor**

Particulars	Single Point Bonded		Both End Bonded	
	65 deg. C Amps	90 deg C Amps.	65 deg. C Amps	90 deg. C Amps
Current Rating conductor size 400 Sq. mm				
a) In Ground				
i. Of each circuits (when both the circuits alive)				
b) In Duct				
i. Of each circuits (when both the circuits alive)				
ii. Of one circuits (when other circuit is isolated)				
c) In pipe, one cable per pipe.				
i. Of each circuits (when both the circuits alive)				
ii. Of one circuits (when other circuit is isolated)				
d) In Air				
i. Of each circuits (when both the circuits alive)				
ii. Of one circuits (when other circuit is isolated)				

**Derating Factors**

<b>1. VARIATION IN GROUND TEMPERATURE :</b>							
Ground Temperature (deg. C) :	15	20	25	30	35	40	45
Rating Factor							
<b>2. VARIATION IN DEPTH OF LAYING :</b>							
Depth of Laying (Meters):	0.7	0.9	1.0	1.2	1.3	1.5	
Rating Factor							
<b>3. VARIATION IN THERMAL RESISTIVITY OF SOIL</b>							
Thermal Resistivity of Soil : (deg. C cm/watt)	100	120	150.0	200	250		
Rating Factor							
<b>4. VARIATION IN AIR TEMPERATURE :</b>							
Air Temperature (deg. C) :	25	30	35	40	45	50	55

Rating Factor							
<b>5. VARIATION DISTANCE (MM) :</b>							
Axial Distance (mm) Between circuits :	100	200	300.0	400	600	800	
Rating Factor							

**AB CABLE**

**A. AERIAL BUNCHED CABLES FOR 33kV LINES**

**SCOPE:**

This specification covers requirements of XLPE insulated, 33 kV Aerial Bunched Cables for overhead lines.

**1. Qualifying Requirement of AB Cable Manufacturer/Supplier**

The manufacturer should have manufactured, successfully type tested and supplied at least one hundred (100) kms of 33 kV or above voltage grade XLPE armoured and/or AB Cable in the last five (5) years as on the date of bid opening.

**2. COMPOSITION OF THE CABLE**

The Composite cable shall comprise three single-core cables twisted around a bare aluminium alloy messenger wire, which will carry the weight of the cable.

**3. RATED VOLTAGE**

The rated voltage of the cables shall be 33 kV and the maximum operating voltage shall be 36 kV.

**4. APPLICABLE STANDARDS**

Unless otherwise stipulated in this Specification, the following standards shall be applicable:

- i) IS: 7098 (part-II) – 1985 – Cross linked Polyethylene Insulated PVC Sheathed Cables.
- ii) IS:9130-1984-Conductors for Insulated Cables
- iii) IS: 398 (Part-IV) – 1979 – Aluminium Alloy Conductors.

**5. DETAILS OF SINGLE CORE CABLE**

5.1 The cable conductors shall be or round standard and compacted aluminium, of nominal cross sectional area 95 mm<sup>2</sup>.

**5.2 Conductor Screen**

The conductor screen shall be of extruded semi-conducting cross linked polyethylene compound of thickness as per relevant IS.

**5.3 Insulation**

The Insulation shall be of extruded cross linked polyethylene (XLPE) of nominal insulation thickness as per relevant IS and its properties shall conform to IS:7098 (Part-II).

**5.4 Insulation Screen**

The insulation screen shall be as per IS:7098 (Part-II).

**5.5 Outer Sheath**

The outer sheath shall be black polyethylene.

**6. MESSENGER (NEUTRAL CONDUCTOR)**

- 6.1 The bare messenger wire shall be of 120 mm<sup>2</sup> (nominal area) aluminium alloy, generally conforming to IS:398 (Part IV) – 1979, comprising multi strands and shall be suitably compacted to have smooth round surface to avoid damage to the outer insulating sheath of single-core phase cables twisted around the messenger.
- 6.2 There shall be no joints in any wire of the stranded messenger conductor except those made in the base rod or wire before finally drawing.

**7. TESTS**

7.1 The following tests shall be carried out on the single-core cables as per IS-7098 (Part-II).

7.1.1 Type Tests

- a) Tests on conductor:
  - i) Tensile test
  - ii) Wrapping test
  - iii) Resistance test
- b) Tests for thickness of insulation and sheath
- c) Physical tests for insulation:
  - i) Tensile strength and elongation at break
  - ii) Agency in air oven
  - iii) Hot test
  - iv) Shrinkage test
  - v) Water absorption
- d) Tests for outer sheath:
  - i) Tensile strength and elongation at break
  - ii) Ageing in air oven
  - iii) Shrinkage test
  - iv) Hot deformation
  - v) Bleeding and blooming test.
- e) Partial discharge test
- f) Bending test
- g) Dielectric Power factor test:
  - i) As a function of voltage
  - ii) As a function of temperature
- h) Insulation resistance test
- g) Heating cycle test
- k) High voltage test
- l) Flammability test

7.1.2 Acceptance Test

- a) Tensile Test
- b) Wrapping Test
- c) Conductor resistance test
- d) Test for thickness of insulation and sheath
- e) Hot set test for insulation
- f) Tensile strength and elongation at break test for insulation and sheath
- g) Partial discharge test
- h) High voltage test
- i) Insulation resistance (volume resistivity) test

7.1.3 Routine Tests

- a) Conductor resistance test
- b) Partial Discharge Test
- c) High voltage test

7.2 The following tests shall be carried out on the bare messenger wire in accordance with IS:398 (Part-IV).

Type Tests/Acceptance Test

- a) Breaking Load Test (on finished wire)
- b) Elongation Test
- c) Resistance Test

8. PACKING AND MARKING

8.1 Packing

Cables shall be supplied in returnable wooden drums conforming to IS: 10418. The standard length of the bunched cable in each drum shall be 250 meters (+/-) 10%. Other lengths may be acceptable subject to the approval of employer/purchaser.

8.2 Marking

The Cable drum shall carry the information as per the requirements of IS: 7098 (Part-II). However, exact details of marking/embossing, color of outer sheath etc. will be as per the detailed purchase order.

8.3 Suitable identification marks shall be given on the outer sheath to clearly distinguish three phases of the bunched cable.

**B. AERIAL BUNCHED CABLES FOR 11kV LINES**

**SCOPE:** This specification covers requirements of XLPE insulated, 11kV Aerial Bunched Cables for overhead lines.

**1.0 Qualifying Requirement of ABCable Manufacturer/Supplier**

The manufacturer should have manufactured, successfully type tested and supplied at least one hundred (100) km of 11kV or above voltage grade XLPE armoured and/or ABC cable in the last five (5) years as on the date of bid opening.

**2. COMPOSITION OF THE CABLE**

The composite cables shall consist of three single-core cables twisted around a bare aluminium alloy messenger wire, which will carry the weight of the cable.

**3. RATED VOLTAGE**

The rated voltage of the cables shall be 6.35kV/11kV and the maximum operating voltage shall be 12kV

**4. APPLICABLE STANDARDS**

Unless otherwise stipulated in this specification, the following standards shall be applicable:

- i) IS:7098 (part-II)-1985 –Cross linked Polyethylene Insulated PVC Sheathed Cables
- ii) IS:8130-1984-Conductors for Insulated Cables
- iii) IS:398(Part-IV)-1979 –Aluminium Alloy Conductors

**5. DETAILS OF SINGLE CORE CABLE**

5.1 The cable conductor shall be of round, stranded and compacted aluminium of nominal cross sectional area 35mm<sup>2</sup> and 70mm<sup>2</sup>. Corresponding nominal conductor diameter and number of wires in the conductor shall be as given in clause 5.7.

**5.2 Conductor Screen**

The conductor screens shall be of extruded semi-conducting crosslinked polyethylene compound of thickness not less than 0.5 mm.

**5.3 Insulation**

The insulation screen shall be as per IS:7098 (Part II).

**5.4 Insulation screen**

The insulation screen shall comprise extruded semi-conducting compound and/or semi-conducting tape. Thickness of the screen shall be not less than 0.6 mm.

**5.5 Outer Sheath**



The outer sheath shall be black polyethylene.  
The nominal thickness of sheath shall be 1.8mm and it shall conform to the technical requirements of ST-3 of EIC-502

**5.6 Dimensional and Electrical Data**

The Dimensional and Electrical Data for single-core cable is given below:

S.No.	Description	Nominal area of conductors	
		35 mm <sup>2</sup>	70mm <sup>2</sup>
I.	Nominal conductor diameter(mm)/No. of wires in conductor	6.8/6	10/12
II.	Approx over dia of cable (mm)	22	25
III.	Max D.C. resistance at 200c Ohm/Km	0868	.443
IV.	Max SC current for 1 Sec. KA	3.4	6.7
V.	Max continuous load (amps)	106	156

Note: Due to limitation of short circuit current rating, it is recommended that 70mm<sup>2</sup> cable is used the base line for the first 4-

5kms from the 33/11kV substation and thereafter the lower size of cable i.e. 35mm<sup>2</sup> can be used depending upon the line loading. Normally the current loading of 70mm<sup>2</sup> cables should not exceed 145amps and that of 35mm<sup>2</sup> cables as 95amps. For a maximum ambient temperature of 50°C.

**6. MESSENGER (NEUTRAL CONDUCTOR)**

- 6.1 The bare messenger wire shall be of 70mm<sup>2</sup> (nominal area) aluminium alloy, generally conforming to IS: 398 (Part IV) – 1979, comprising of seven (7) strands and shall be suitably compacted to have smooth round surface to avoid damage to the outer insulating sheath of single-core phase cables twisted around the messenger.
- 6.2 There shall be no joints in any wire of the stranded messenger conductor except those made in the base rod or wire before finally drawing.
- 6.3 The technical characteristics of messenger wire shall be as follows:

i.	Nominal sectional area (mm <sup>2</sup> )	70
ii.	Nos. of wire	7
iii.	Nominal dia of wires / compacted conductor (approx.) mm	3.5/10
iv.	Approx. Mass kg/Km	184
v.	D.C. resistance at 20°C Ohm/Km	0.493
vi.	Breaking load (KN)	20
vii.	Modulus of elasticity (approx) KN/mm <sup>2</sup>	59
viii.	Coefficient of linear expansion	23 x 10 <sup>-6</sup> /°C

Note: the value of item vi above is to be guaranteed. A tolerance of (-)5% is permissible on the value in item vi above.

## 7. DESIGNATION AND PARAMETER OF FINISHED CABLES

The designation and parameter of finished cables are given in the following table:

S.No.	Designation	Complete bunched cables	
		Overall dia approx mm	Total mass (Approx.) Kg/Km
I.	3x35+70	53	1450
II.	3x70+70	59	1900

Note: the first part of the designation refers to the number and size of phase conductor and the second to the size of messenger wire. The sizes shown represent the nominal cross-sectional area in mm.

## 8. TESTS

8.1 The following tests shall be carried out on the single-core cables as per IS-7098 (Part-II).

### 8.1.1 Type Tests

- a) Tests on conductor:
  - i) Tensile test
  - ii) Wrapping test
  - iii) Resistance test
- b) Tests for thickness of insulation and sheath
- c) Physical tests for insulation:
  - i) Tensile strength and elongation at break
  - ii) Agency in air oven
  - iii) Hottest
  - iv) Shrinkage test
  - v) Water absorption
- d) Tests for outer sheath:
  - i) Tensile strength and elongation at break
  - ii) Ageing in air oven
  - iii) Shrinkage test
  - vi) Hot deformation

- vii) Bleeding and blooming test.
- e) Partial discharge test
- f) Bending test
- g) Dielectric Power factor test:
  - i) As a function of voltage
  - ii) As a function of temperature
- h) Insulation resistance test
- g) Heating cycle test
- k) High voltage test
- l) Flammability test

#### 8.1.2 **Acceptance Test**

- a) Tensile Test
- b) Wrapping Test
- c) Conductor resistance test
- d) Test for thickness of insulation and sheath
- e) Hot set test for insulation
- f) Tensile strength and elongation at break test for insulation and sheath
- g) Partial discharge test
- h) High voltage test
- i) Insulation resistance (volume resistivity) test

#### 8.1.3 **Routine Tests**

- a) Conductor resistance test
- b) Partial Discharge Test
- c) High voltage test

#### 8.2 **The following tests shall be carried out on the bare messenger wire in accordance with IS:398 (Part-IV).**

Type Tests/Acceptance Test

- a) Breaking Load Test (on finished wire)
- b) Elongation Test
- c) Resistance Test

### 9. **PACKING AND MARKING**

#### 9.1 **Packing**

Cables shall be supplied in returnable wood end drums conforming to IS: 10418. The standard length of the bunched cable in each drum shall be 1000 meters (+/-) 10%. Other lengths may be acceptable subject to the approval of employer/purchaser.

## 9.2 **Marking**

The Cable drum shall carry the information as per the requirements of IS: 7098 (Part-II). However, exact details of marking/embossing, color of outer sheath etc. Will be as per the detailed purchase order.

- 9.3 Suitable identification marks shall be given on the outer sheath to clearly distinguish three phases of the bunched cable.

**12. LT Aerial Bunched Cables**

**(APPLICABLE FOR LT AB CABLE WITH XLPE INSULATION ONLY)**

**1. SCOPE:**

This specification covers XLPE insulated Aluminum cable twisted over a central bare Aluminum Alloy messenger wire for use of L.T. Over-Headlines in Rural Electrification System. The Aerial Bunched cable and messenger wire should be confirming to IS.

(Sizes: of the cable)

- 1.01 1X16 (Ph) + 1X25 (bare messenger cum neutral) SQ. MM.
- 1.02 1X16 (Ph) + 1X25 (bare messenger cum neutral) + 1x16 (insulated Street lighting)SQ. MM.
- 1.03 3X16(Ph)+1X25 (bare messenger cum neutral) SQ. MM.
- 1.04 3 X 16(Ph) +1x25 (bare messenger cum neutral) + 1x16 (insulated Street lighting) SQ. MM.
- 1.05 1X25(Ph)+1x25 (bare messenger cum neutral) SQ. MM.
- 1.06 1X25(Ph) + 1X25 (bare messenger cum neutral) + 1x16 (insulated Street lighting) SQ. MM.
- 1.07 3X25(Ph)+1X25 (bare messenger cum neutral) SQ. MM.
- 1.08 3 X 25(Ph) +1x25 (bare messenger cum neutral) + 1x16 (insulated Street lighting) SQ. MM.
- 1.09 1X35(Ph)+1X25 (bare messenger cum neutral) SQ. MM.
- 1.10 1x35(Ph) + 1X25 (bare messenger cum neutral) + 1x16 (insulated Street lighting) SQ. MM.
- 1.11 3X35(Ph)+1X25 (bare messenger cum neutral) SQ. MM.
- 1.12 3X35 (Ph) + 1x25 (bare messenger cum neutral)+ 1x16 (insulated Street lighting) SQ. MM.
- 1.13 3X50(Ph)+1X35 (bare messenger cum neutral) SQ. MM.
- 1.14 3X50 (Ph)+1x35 (bare messenger cum neutral) +1x16 (insulated Street lighting) SQ. MM.
- 1.15 3X95(Ph)+1X70 (bare messenger cum neutral) SQ. MM.
- 1.16 3X95(Ph)+1X70 (bare messenger cum neutral) SQ. MM.+1x16 (insulated Street lighting)SQ. MM.

**2. RATED VOLTAGE:**

The rated voltage of the AB cables shall be 1100 volts

**3. APPLICABLE STANDARDS:**

Unless otherwise stipulated in this specification the following Standards shall be applicable.

- i) IS – 14255/1995 : ABC cables 1100 volts.
- ii) IS – 8130/1984 : Conductors for insulated cables.
- iii) IS – 398/Pt.IV/1994: Aluminium alloy conductor.
- iv) IS – 10418/1982 : Drums for electric cables

**4. GENERAL:**

The AB cable covered under this specification should be suitable for use on three phase, 4 wire earthed system for working voltage up to 1100 V. It should confirm the relevant standards stated above and others if applicable.

The phase conductor shall be 95 mm<sup>2</sup>, 50 mm<sup>2</sup>, 35 mm<sup>2</sup>, 25 mm<sup>2</sup> and 16 mm<sup>2</sup> XLPE insulated and the messenger-cum-neutral conductor of sizes 70 mm<sup>2</sup>, 35 mm<sup>2</sup> and 25 mm<sup>2</sup> shall be bare heat treated aluminium-magnesium-silicon alloy wires containing 0.5% magnesium and approximately 0.5% silicon confirming to IS: 398 (Part-IV):1979 and its latest amendment, if any.

**5. PHASE CONDUCTORS:**

- 5.1 The phase & street lighting conductor shall be provided cross linked poly ethylene insulation applied by extrusion. The thickness of insulation shall not be less than 1.2 mm up to 35mm<sup>2</sup> and shall not be less than 1.5 mm for above 35mm<sup>2</sup> at any point and insulation shall be so applied that it fits closely on the conductor and it shall be possible to remove it without damaging the conductor. The insulated conductors shall generally conform to the standards IS-14255:1995.
- 5.2 The phase conductors shall be provided with one, two & three 'ridges' for easy identification.
- 5.3 The tensile strength of the aluminum wire used in the conductor shall not be less 90 N/mn<sup>2</sup>.
- 5.4 The standard size and technical characteristics of the phase conductors shall be as shown in the Table-1.

**TABLE-I**

Nominal Sectional area in mm <sup>2</sup>	No. of Strands	Diameter of Compacted conductor in mm	Approx. Mass Kg/KMs.	Max. DC Résistance at 20 <sup>o</sup> c (Ohm/km)	Insulation Thickness in mm
1	2	3	4	5	6
16	7	4.4	42	1.91	1.2
25	7	5.6	65	1.20	1.2
35	7	6.7	95	0.868	1.2
50	7	8.0	127	0.641	1.5
95	19	11.0	266	0.320	1.5

NOTE: 1) The resistance values given in col.5 are the max. permissible.

Tolerance of + 5% is allowable on dimension.

**6. MESSENGER-CUM-NEUTRAL WIRE:**

- 6.1 The bare messenger wire shall be of aluminium alloy generally confirming to IS-398/Pt.IV/94 composed of 7 strands and shall be suitable compacted or stranded to have smooth round surface to avoid damages to the overall insulation of phase & neutral conductor twisted around the messenger.

6.2 There shall be no joint in any wire of the stranded messenger Conductor except these made in the base rod or wires before final drawing.

6.3 The sizes and other technical characteristics of the messenger wire shall be as given in the Table No.2.

TABLE –2

Nominal Sectional Area in mm <sup>2</sup>	No. of strands	Diameter of Compacted conductor in mm	Diameter of Stranded conductor in mm	Approx. Mass Kgs/KMs	Max .DC Resistance
1	2	3	4	5	6
25	7	5.6	6.42	65	1.380
35	7	6.7	7.56	95	0.986
70	7	9.4	10.65	196	0.492

NOTE: while limiting values in col. 3 is to be guaranteed a tolerance of + 5% will be permissible.

**7. XLPE INSULATION:**

The insulation shall generally conform to IS-14255

Sr.No.	Property	Requirement
1	Tensile Strength	12.5 N / mm <sup>2</sup> Min
2	Elongation at break	200 % Min.
3	Ageing in air over	
a	Treatment: Temperature & duration	135 ± 3°C & 7 days
b	Tensile strength variation	± 25% Max.
c	Elongation variation	± 25% Max.
4	Hot Set	
a	Treatment temperature, Time Under load, mechanical stresses	200 ± 3°C, 15 minutes 20 N /cm <sup>2</sup> .
b	Elongation under load	175 % max.
c	Permanent elongation (set) after cooling	15 % Max
5	Shrinkage	
a	Treatment temperature duration	130 ± 3°C For 1 hour

Sr.No.	Property	Requirement
b	Shrinkage	4% Max
6	Water absorption (Gravimetric)	
a	Treatment– Temp.	85 ± 2°C
	Duration	14 days
b	Water absorbed	1 mg. / cm <sup>2</sup> max.

**8. TYPE TEST:**

**A. Test for Phase/Street Light Conductors**

- (iv) Tensile Test (IS-8130)
- (v) Wrapping Test (IS-8130)
- (vi) Conductor Resistance Test (IS-8130)

**B. Test for Messenger:**

- (i) Breaking load test (to be made on finished conductor) -(IS-398/ Pt.IV/ 1994 with latest revision)
- (ii) Elongation test (IS - 398 / Pt.IV/1994)
- (iii) Resistance test (IS - 398 / Pt. IV /1994)
- (iv) If insulated , the test of insulation as per relevant IS will be applicable

**C. Physical test for XLPE insulation**

- (v) Tensile strength and Elongation at break
- (vi) Ageing in air oven
- (vii) Hot set test
- (viii) Shrinkage test
- (ix) Water absorption (Gravimetric)
- (x) Carbon black 1. Content & 2. Dispersion

**D. Test for thickness of insulation**

**E. Insulation Resistance (Volume Resistivity ) Test**

**F. High Voltage Test**



Note: The Manufacturer should submit the entire above type test of Govt. of India's approved Laboratory along with their offer.

**Optional Test:**

Bending test on the completed cable:

Bending test shall be performed on a sample of complete cable. The sample shall be bent around a test mandrel at room temperature for at least one complete turn. It shall then be unwound and the process shall be repeated after turning the sample around its axis 180°. The cycle of this operation shall be then repeated twice.

The diameter of mandrel shall be  $10(D+d)$ .

Where

D = Actual diameter of cable (i.e. the min. circumscribing diameter in mm) d = Actual diameter of the phase conductor in mm

No cracks visible to the naked eye are allowed.

**9. ACCEPTANCE TESTS:**

Tests for Phase / Street Light Conductors:

- a. Tensile test (for Phase / Street light conductor)
- b. Wrapping test (for Phase / Street light conductor)
- c. Breaking load test for messenger conductor
- d. Elongation test for messenger conductor
- e. Conductor Resistance test
- f. Test for thickness of insulation
- g. Tensile strength and elongation at break test
- h. Hot set test ( For XLPE insulation)
- i. Insulation Resistance test
- j. High voltage test

**10. PACKING MARKING:**

- 10.1 The LT AB cable shall be wound in nonreturnable drums conforming to IS-10418/1982 "Specification for Reels and Drums for bare wire" of the latest version thereof. The drums shall be marked with the following:

- d) Manufacturers name
- e) Trade mark if any
- f) Drum number
- g) Size of Conductor
- h) Size of Messenger
- i) Voltage grade
- j) Number of lengths of pieces of Cable in each drum
- k) Gross mass of the packing
- l) Net mass of Cable
- m) ISI mark

10.2 The drums shall be of such a construction as to assure delivery of conductor in field free from displacement and damage and should be able to withstand all stresses due to handling and the stringing operation so that cable surface not dented, scratched or damaged in any way during transport and erection. The cable shall be properly lugged on the drums

10.3 The cable drums should be suitable for wheel mounting.

**11. STANDARD LENGTH:**

The standard length of drum will be 500 meter with  $\pm 5\%$

**Non-standard Length:**

Nonstandard length not less than 50% of the standard length shall be accepted to the extent of 10% of the ordered quantity.

**12. INSPECTION:**

All tests and inspections shall be made at the place of manufacturer unless otherwise especially agreed upon by the manufacturer and purchaser at the time of purchase. The manufacturer shall afford the inspector representing the purchaser all reasonable facilities, without charge, to satisfy him that the material is being furnished in accordance with this specification.

**13. EXPERIENCE:**

The manufacturer must have some experience of manufacturer and supply of this cable to any Electricity Board. Copy of order executed and performance report may be submitted along with the offer.

**14. TYPE TEST CERTIFICATES:**

The duly attested copy of Type Test Certificate of the offered sizes of AB cable, as per IS: 14255/1995 with latest amendment/revision be submitted from any Govt. laboratory or from a NABL accredited laboratory along with the offer. Type Test Certificate shall not be more than Five Years Old from Date of supply.

However, if the same are not available at the time of bidding, the same may be submitted after order but before commencement of supply.

In case, the bidder is not able to submit the Type Test Certificate from any Govt. laboratory or from a NABL accredited laboratory for any size of cable, the same shall be conducted by the bidder free of cost without any additional financial liability on utility. For this purpose, Type test Report of a phase wire or messenger wire once tested shall be accepted for all other combination. For example, if 1x16 + 25 sq mm and 3x35 + 25 sq mm already tested then this will be valid for 3x16+25 sq mm (as phase wire of 16 sq mm and messenger wire of 25 sq mm are already tested) and for 3x35 + 25 sq mm + 16 sq mm (as phase wire of 35 & 16 sq mm and messenger wire of 25 sq mm are already tested).

**15. SUBMISSION OF ISI LICENSE FOR IS14255:1995**

The Manufacturer are required to submit duly attested photo copy of the valid ISI License up to the date of delivery for supply of these AB cables/wires and they should also submit GTP failing which, the offer would be ignored.

**16. IMPORTANT:**

In absence of valid ISI License/GTP duly filled in/and copy of type test certificate of Govt. approved Laboratory, duly attested by authorized person, offer will be liable to be ignored without any further correspondence.

**17. ISI MARKING:**

The material supplied shall be conforming to Indian Standard Specification and also with ISI marking as applicable and even after inspection of the lot, if the materials received at site is found without ISI marking, the lot shall be rejected and no further correspondence shall be entertained in this regard.

Exact details of marking/embossing, color of outer sheath etc. will be as per the detailed purchase order.

**GUARANTEED TECHNICAL PARTICULARS (G.T.P.)**

Technical information and Guaranteed Technical Particulars (G.T.P.) for LT Aerial Bunched Cable (XLPE insulated only) of sizes:

- 1.01 1X16 (Ph) + 1X25 (bare messenger cum neutral) SQ. MM.
- 1.02 1X16 (Ph) + 1X25 (bare messenger cum neutral) + 1x16 (insulated Street lighting)SQ. MM.
- 1.03 3X16(Ph)+1X25 (bare messenger cum neutral) SQ. MM.
- 1.04 3 X 16(Ph) +1x25 (bare messenger cum neutral) + 1x16 (insulated Street lighting) SQ. MM.
- 1.05 1X25(Ph)+1x25 (bare messenger cum neutral) SQ. MM.
- 1.06 1X25(Ph) + 1X25 (bare messenger cum neutral) + 1x16 (insulated Street lighting) SQ. MM.
- 1.07 3X25(Ph)+1X25 (bare messenger cum neutral) SQ. MM.
- 1.08 3 X 25(Ph) +1x25 (bare messenger cum neutral) + 1x16 (insulated Street lighting) SQ. MM.
- 1.09 1X35(Ph)+1X25 (bare messenger cum neutral) SQ. MM.
- 1.10 1x35(Ph) + 1X25 (bare messenger cum neutral) + 1x16 (insulated Street lighting) SQ. MM.
- 1.11 3X35(Ph)+1X25 (bare messenger cum neutral) SQ. MM.
- 1.12 3X35 (Ph) + 1x25 (bare messenger cum neutral)+ 1x16 (insulated Street lighting) SQ. MM.
- 1.13 3X50(Ph)+1X35 (bare messenger cum neutral) SQ. MM.
- 1.14 3X50 (Ph)+1x35 (bare messenger cum neutral) +1x16 (insulated Street lighting) SQ. MM.
- 1.15 3X95(Ph)+1X70 (bare messenger cum neutral) SQ. MM.
- 1.16 3X95(Ph)+1X70 (bare messenger cum neutral) SQ. MM.+1x16 (insulated Street lighting)SQ. MM.

**PART – A**

Manufacturer has to confirm following important requirements:

Sr. No.	Particulars	confirmation
1	AB Cable shall be manufactured and supplied Confirming to IS: 14255/1995 with latest Amendment if any	Yes
2	Cable drums/label shall bear ISI Mark	Yes
3	ISI License shall remain valid till order is Completed	Yes
4	Colour of XLPE Insulation – Black	
4a	1X16 + 1X25 SQ. MM.	Yes
4b	1X16 + 1X25 + 1x16 SQ. MM.	Yes
4c	3X16+1X25 SQ. MM.	Yes
4d	3 X 16 +1x25 + 1x16 SQ. MM.	Yes
4e	1X25+1x25 SQ. MM.	Yes
4f	1X25 + 1X25 + 1x16 SQ. MM.	Yes
4g	3X25+1X25 SQ. MM.	Yes
4h	3 X 25 +1x25 + 1x16 SQ. MM.	Yes
4i	1X35+1X25 SQ. MM.	Yes

4j	1x35 + 1X25 + 1x16 SQ. MM.	Yes
4k	3X35+1X25 SQ. MM.	Yes
4l	3X35 + 1x25 + 1x16 SQ. MM.	Yes
4m	3X50+1X35 SQ. MM.	Yes
4n	3X50 +1x35 +1x16 SQ. MM.	Yes
4o	3X95+1X70 SQ. MM.	Yes
4p	3X95+1X70 +1x16 SQ. MM.	Yes
5	Shape – compacted	Yes
6	Standard length in case 500 mtrs+ 5 % tolerance longer length acceptable	Yes
7	Non-Standard length 50% of Std. length up to 10%of ordered quantity	Yes
8	Packing shall contain only one Length.	Yes
9	Packing material: Wooden drums as per IS: 10418/1982 duly painted	Yes
9a	1X16 + 1X25 SQ. MM.	Yes
9b	1X16 + 1X25 + 1x16 SQ. MM.	Yes
9c	3X16+1X25 SQ. MM.	Yes
9d	3 X 16 +1x25 + 1x16 SQ. MM.	Yes
9e	1X25+1x25 SQ. MM.	Yes
9f	1X25 + 1X25 + 1x16 SQ. MM.	Yes
9g	3X25+1X25 SQ. MM.	Yes
9h	3 X 25 +1x25 + 1x16 SQ. MM.	Yes
9i	1X35+1X25 SQ. MM.	Yes
9j	1x35 + 1X25 + 1x16 SQ. MM.	Yes
9k	3X35+1X25 SQ. MM.	Yes
9l	3X35 + 1x25 + 1x16 SQ. MM.	Yes
9m	3X50+1X35 SQ. MM.	Yes
9n	3X50 +1x35 +1x16 SQ. MM.	Yes
9o	3X95+1X70 SQ. MM.	Yes
9p	3X95+1X70 +1x16 SQ. MM.	Yes
10	Following shall be embossed on cable & Marking on drum shall be as per IS: 14255/1995	Yes
10a	Purchaser (Employee)	Yes
10b	1100 Volts	Yes
10c	IS:14255/1995	Yes
10d	Year of manufacture	Yes
10e	Trade Mark	Yes
11	Conductor –	
11a	For Phase 16 mm <sup>2</sup> ,25 mm <sup>2</sup> , 35 mm <sup>2</sup> , 50 mm <sup>2</sup> & 95 mm <sup>2</sup> Aluminium as per	Yes

	IS 8130/1984	
11b	For Messenger wire 25 mm <sup>2</sup> , 35 mm <sup>2</sup> & 70 mm <sup>2</sup> Aluminium Alloy as per IS 398/Pt.IV/1994	Yes
12	Maximum Conductor resistance at 20°C For Phase Conductor	
12a	16 mm <sup>2</sup> Conductor – 1.91 Ohm/KM	Yes
12b	25 mm <sup>2</sup> Conductor – 1.20 Ohm/KM	Yes
12c	35 mm <sup>2</sup> Conductor – 0.868 Ohm/KM	Yes
12d	50 mm <sup>2</sup> Conductor – 0.641 Ohm/KM	Yes
12e	95 mm <sup>2</sup> Conductor – 0.320 Ohm/KM	Yes
	For messenger conductor	
12e	25 mm <sup>2</sup> Conductor – 1.380 Ohm/KM	Yes
12f	35 mm <sup>2</sup> Conductor – 0.986 Ohm/KM	Yes
12g	70 mm <sup>2</sup> Conductor – 0.492 Ohm/KM	Yes
13	Minimum average XLPE Insulation thickness for AB Cable	
13a	16 mm <sup>2</sup> - 1.2 mm	Yes
13b	25 mm <sup>2</sup> - 1.2 mm	Yes
13c	35 mm <sup>2</sup> - 1.2 mm	Yes
13d	50 mm <sup>2</sup> - 1.5 mm	Yes
13f	95 mm <sup>2</sup> - 1.5 mm	Yes
14	Volume resistivity of insulation	
14a	At 27°C – 1 x 10 <sup>13</sup> Ohm-cm. Min	Yes
14b	At 70°C – 1 x 10 <sup>11</sup> Ohm-cm. Min	Yes
15	Tensile strength of Insulation & sheath -12.5 N/mm <sup>2</sup> Min.	Yes
16	Elongation at break of Insulation and Sheath –200% Min.	Yes
17	Overall tolerance in supply of ordered total quantity shall be ± 2 % ( Plus and minus two %)	Yes

**PART- B**

Manufacturer has to furnish below details about material for information;

Sr. No.	Particulars				confirmation
1	ISI License for IS:14255/1995				Yes
1a	Number				
1b	Date of expiry				
2	Approximate weight of 1000 meters length (Weight in Kgs.)				
2a	Size of cable	Alum.	Alu. Alloy	XLPE	Total
	1X16 + 1X25 SQ. MM.				
	1X16 + 1X25 + 1x16 SQ. MM.				
	3X16+1X25 SQ. MM.				
	3 X 16 +1x25 + 1x16 SQ. MM.				
	1X25+1x25 SQ. MM.				
	1X25 + 1X25 + 1x16 SQ. MM.				
	3X25+1X25 SQ. MM.				
	3 X 25 +1x25 + 1x16 SQ. MM.				
	1X35+1X25 SQ. MM.				
	1x35 + 1X25 + 1x16 SQ. MM.				
	3X35+1X25 SQ. MM.				
	3X35 + 1x25 + 1x16 SQ. MM.				
	3X50+1X35 SQ. MM.				
	3X50 +1x35 +1x16 SQ. MM.				
	3X95+1X70 SQ. MM.				
3X95+1X70 +1x16 SQ. MM.					
3	Cable Conductor, Circular Compacted?				Yes

**PART – C (ENCLOSURES)**

Manufacturers have to enclose following documents and has to confirm for the same

Sr. No.	Particulars	confirmation	
1	ISI License	Yes	
2	Proof if applied for renewal of ISI License	Yes	
3	TYPE TEST CERTIFICATE:Type test certificate from Govt. of India approved Laboratory	Yes	
	Size of AB Cable		
	a Name of Lab. & City Name		
	b T.R. No.		
c Date			
4	List of plant and machinery	Yes	
5	List of testing facility available	Yes	
6	List of orders pending/executed	Yes	
6a	with Employer	Yes	
6b	with agencies other than Sr. no. 6(a)	Yes	



**13. XLPE Power Cables (11kV&33 kV)**

**SECTION I**

**STANDARD TECHNICAL REQUIREMENT**

**1.0 SCOPE:**

This section covers the standard technical requirements of design, manufacturing, testing, packing and dispatching of 11 kV and 33 kV XLPE HT Power Cable.

**2.0 APPLICABLE STANDARDS**

The materials shall conform to the latest editions of the following Indian/International Standards :

IS 7098 Part 2 : 1985 XLPE insulated PVC sheathed cables For working voltages from 3.3 kV up to and including 33 kV

IS 5831 : 1984 PVC Insulation and Sheath of electric Cables

IS 8130:1984 Conductors for insulated electric cables and flexible cords. IS 613:1984 Copper rods and bars for electrical purposes.

IS 3975:1988 Mild steel wires, formed and tapes for armouring of cable. IS 10810:1984 Method of tests for cables.

IEEE-383:1974 Standard for type test of class IE electric cables, field splices, and connections for nuclear power generating stations.

ASTM-D2843,1993 Standard test method for density of smoke from burning or decomposition of plastics.

ASTM-D2863, 1991 Standard test method for measuring minimum oxygen concentration to support candle - like combustion of plastics (oxygen index).

NEMA-WC5,1992 Thermoplastic Insulated Wire and cable for the transmission and distribution of Electrical Energy.

IEC:754 Test on gases evolved during combustion of electric cables -

(Part-1):1994 Determination of the amount of halogen acid gas evolved during combustion of polymeric materials taken from cables.

IEC:332 Test on electric cables under fire conditions

(Part I):1993 Test on a single vertical insulated wire or cable. IS 3961 Recommended current rating for cables -

(Part II):1967 PVC insulated and PVC sheathed heavy duty cables.

IS 10418:1982 Drums for electric cables.

**3.0 GENERAL REQUIREMENTS**

All cables shall be suitable for high ambient, high humid tropical Indian Climatic conditions. Cables shall be designed to withstand the mechanical, electrical and thermal stresses under the unforeseen steady state and transient conditions and shall be suitable for proposed method of

installation.

Conductor shall be of uniform, of good quality, free from defects Aluminium copper.

Insulation shall be Cross Linked Polyethylene (XLPE) .

For 33 kV and 11 kV cables, conductor screen and insulation screen shall both be extruded, semi-conducting compound and shall be applied along-with XLPE insulation in a single operation by triple extrusion process. Method of curing for 33 kV cable shall be "Dry curing/ gas curing " only, whereas for 11 kV and 3.3 kV cables it shall be "Dry curing/ gas curing / Steam curing".

Extruded Semi-conducting screening and metallic screening of copper tape shall be generally as per IS 7098 (Part-II) with latest amendments. The semi conducting compound shall be suitable for the operating temperature of the cable and compatible with the insulating material.

The insulation screen shall be an extruded layer of black semi-conducting compound and continuously covers the whole area of insulation. The semi-conducting screens should be effectively cross linked to achieve 90 ° C cable rating. The contact surface between insulation and insulation screen shall be smooth and free from protrusion and irregularities.

The interface between insulation and insulation screen shall be free of any voids. Insulation screen shall be strippable type.

The metallic screen shall consist of a layer of copper cable applied in helical form.

Inner sheath - All armoured and multi-core un-armoured cables shall have distinct extruded inner PVC sheath of black colour.

Armouring - Material for armour for Single Core Cable shall be Aluminum wire. For Multicore cable it shall be GS wire / flat. Armouring shall be as per relevant IS and it shall have minimum 90% coverage.

Breaking Load of the joints shall be minimum 95% of the normal armour.

Outer Sheath – It shall be of black colour PVC (type ST2 as per IS 5831) with Cable size and Voltage grade embossed on it. Sequential marking shall be at every 1 (one ) Meter distance. Word "FRLS" shall also be embossed on it at every 5 (Five ) meter distance.

FRLS Properties - All cable shall be Flame Retardant, Low Smoke (FRLS) type. Outer sheath shall have the following properties –

Acid Gas Generation – Max 20% ( as per IEC 754-1)

Smoke density rating: 60% (As per ASTM D 2843)

Flammability test - As per Swedish chimney test F3 as per SEN 4241475

As per IEC 332 part-3 (Category B)

Minimum bending radius shall be 10 D

Repaired cables shall not be acceptable.

#### **4.0 CURRENT RATING OF CABLES**

- 1) Normal current rating shall not be less than that covered by IS 3961. Vendor shall submit data in respect of all cables in the prescribed format.
- 2) Tables given de-rating factors for various conditions of cable installation including the following, for all types of cables shall be furnished.

- Variation in ambient air temperature. - Variation in ground temperature.
  - Depth of laying.
  - Cables laid in the ground - Cables laid in trench
  - Cables laid in ducts - Soil resistivity.
  - Grouping of cables.
- 3) The value of short circuit withstand current ratings of all cables shall be indicated for a short circuit for 1 second duration and should also specify the maximum temperature during short circuit.
  - 4) The following factors shall also be accounted for, while specifying the maximum short circuit withstand of the cables.
  - 5) Deformation of the insulation, due to thermo-mechanical forces produced by the short circuit conditions, can reduce the effective thickness of insulation.
  - 6) Conductor and core screens can be adversely affected with loss of screening effect. Likewise the thermal properties of the outer sheath material can be the limitation.
  - 7) It is essential that the accessories which are used in the cable system with mechanical and/or soldered connections are suitable for the temperature adopted for the cables.
  - 8) Formula for calculating short circuit current for different duration or curve showing short time current v/s time for different sizes of cables shall be furnished by vendor.

## **5.0 CABLE DRUMS**

- 5.1 Cables shall be supplied in non-returnable wooden or steel drums of heavy construction and drum shall be properly seasoned, sound and free from defects. Wood preservative shall be applied to the entire drum.
- 5.2 All Power Cables shall be supplied in drum length of 1000 m. Each drum shall contain one continuous length of cable. Owner shall have the option of rejecting cable drums with shorter lengths. The cable length per drum is allowed a tolerance of  $\pm 5\%$ . The tolerance allowed on total quantity of each size is as given below.
  - 3.250 meters for cable length upto 10 kms.
  - 3.3100 meters for cable length more than 10 kms. and up to 20 kms.
  - 3.4150 meters for cable length more than 20 kms.

Where the ordered quantity is not multiple of 1000 m and the incremental quantity is very small, the same may be included in one of the drums. Otherwise, an additional length for the incremental quantity will be supplied.
- 5.3 A layer of water proof paper shall be applied to the surface of the drums and over the outer most cable layer.
- 5.4 A clear space of at least 40mm shall be left between the cables and the logging.
- 5.5 Each drum shall carry manufacturer's name, purchaser's name, address and contract number, item number and type, size and length of the cable, net and gross weight stenciled on both sides of drum. A tag containing the same information shall be attached to the leading end of the cable. An arrow and suitable accompanying wordings shall be marked on one end of the reel indicating the direction in which it should be rolled.
- 5.6 Packing shall be sturdy and adequate to protect the cables, from any injury due to mishandling or other conditions encountered during transportation, handling and storage. Both cable ends shall be sealed with PVC/Rubber caps so as to eliminate ingress of water during transportation and erection.

## 6.0 TESTS

### 6.1 Type Tests

The following shall constitute type tests:

- i) Tests on conductor
  - a. Annealing test (for copper)
  - b. Tensile tests (for aluminium)
  - c. Wrapping tests (for aluminium)
  - d. Resistance test
- ii) Tests for armouring wires/strips
- iii) Test for thickness of insulation and sheath
- iv) Physical tests for insulation
  - a. Tensile strength and elongation at break
  - b. Ageing in air oven
  - c. Hot test
  - d. Shrinkage test
  - e. Water absorption (gravimetric)
- v) Physical tests for out sheath
  - a. Tensile strength and elongation at break
  - b. Ageing in air oven
  - c. Hot test
  - d. Shrinkage test
- vi) Bleeding and blooming tests (for outer sheath)
- vii) Partial discharge test
- viii) Bending test
- ix) Dielectric power factor test
  - a. As a function of voltage
  - b. As a function of temperature
- x) Insulation resistance (volume receptivity) tests
- xi) Heating cycle test
- xii) Impulse withstand test
- xiii) High voltage test
- xiv) Flammability test

### 6.2 Acceptance tests

The following shall constitute acceptance tests:

- a. Annealing test (for copper)

- b. Tensile test (for aluminium)
- c. Wrapping tests (for aluminium)
- d. Conductor resistance test,
- e. Test for thickness of insulation
- f. Hot set test for insulation,
- g. Tensile strength and elongation at break test for insulation and sheath
- h. Partial discharge test (for screened cables only)
- i. High voltage test and
- j. Insulation resistance (volume resistivity) test

6.3 Routine test

The following shall constitute routine tests:

- i) Conductor resistance test
- ii) Partial discharge test (for screened cables only) and
- iii) High voltage tests.

6.4 Optional tests

Cold impact tests for outer sheath (IS:5831-1984) shall constitute the optional tests.

**SECTION II**

**SPECIFIC TECHNICAL REQUIREMENTS AND QUANTITIES.**

1.0 **SCOPE**

This section of the specification covers project information, site condition, desired Technical parameters and quantity of XLPE Cable.

1.1 Project Information

- a. Customer :
- b. Engineer/Consultant :
- c. Project Location :
- d. Transport facilities
  - i) Nearest Railway station : /Gauge
  - ii) Distance from site :
- e. Access Roads :

1.2 **SITE CONDITIONS**

- (i)** Ambient air temp. (max.) °C :
- (ii)** Ambient air temp. (min.) °C :
- (iii)** Design ambient temp. °C :

1.2.1 Relative humidity for design : purposes

1.2.2 Height above mean sea level in : meters

1.2.3 Earth quake data

- i) Seismic zone : IS:1893-84
- ii) Seismic acceleration : As per IS 2.2.4

1.2.4 Wind data

Site Wind Pressure Kg/m<sup>2</sup> : As per IS 2.3

1.3 System Particulars

a.	Line Voltage (kV)	11/33
b.	Highest System Voltage (kV)	12/36
c.	Number of Circuits	1
d.	Frequency	HZ50
e.	Neutral	effectively earthed
f.	Short circuit level (KA)	22.77 KA, 31.8KA / 22.5KA,45KA

**1.4 SPECIFIC TECHNICAL REQUIREMENTS**

Technical Parameters of the cable shall be as follows:

S. No.	PARTICULAR	Unit	DATA	DATA
1	Rated Voltage	kV	6.35/11	19.0/33
2	Type of Insulation	-	XLPE	XLPE
3	Single core/ Multi core	-	Single/Three core	Single/Three core
4	Armoured / Unarmoured	-	Armoured	Armoured
5	Material of Conductor	-	Aluminium/Copper	Aluminium/Copper
6	System	-	11 kV Earthed	33 kV Earthed
7	Highest System Voltage	kV	12	36
8	Conductor size	sq. mm	120, 150, 185, 240, 300	150, 185, 240, 300, 400
9	Material		Stranded Aluminium/copper	Stranded Aluminium/copper
10	Shape of Conductor		Circular	Circular
11	Short Circuit Current	kA	13.12, 18.35 for 3 secs.	13.12, 26.24 for 3 secs
12	Power Frequency Withstand Voltage	KV rms	28	70
13	Lightning Impulse Withstand Voltage	kVp	75	170
14	Continuous Withstand Temperature	Deg C	90	90
15	Short Circuit withstand Temperature	Deg C	250	250
16	Oxygen Index		Min 29 (as per ASTM D 2863)	Min 29 (as per ASTM D 2863)
17	Acid Gas Generation		Max 20% ( as per IEC 754-1)	Max 20% ( as per IEC 754-1)
18.	Smoke Density Generation		60% (As per ASTM D 2843)	60% (As per ASTM D 2843)
19.	Flammability Test		As per Swedish Chimney test	As per Swedish Chimney test

SECTION-III  
 GUARANTEED TECHNICAL PARTICULARS

Sl. No.	Item Particulars	Unit
1	Manufacturers Name & Address	
2	Country of manufacturer	
3	Type of cable	
4	Applicable standards for manufacturing	
5	Applicable standards for testing	
6	Rated voltage	kV
7	Maximum service voltage	kV
8	Maximum continuous current carrying capacity per cable when lain in air at an ambient air temperature of 50 deg. (single core cables solid bonded)	A
9	Maximum continuous current carrying capacity per cale when lain in ground at a depth of 1.0 m (ground temp. 40 deg. C and soil thermal resistivity of 150 deg.c/watt/cm max. Conductor temp. 90 deg. C) (single core cables solid bonded)	A
10	Maximum continuous current carrying capacity per cable when drawing into duct./pipes (single core cables solid bonded)	A
11	Maximum continuous current carrying capacity per cable when lain in covered RCC trenches at an ambient temperature of 50 Deg. C laying conditions to be specified (Single core cables solid bonded)	A
12	Short circuit withstand capacities for 1 second of (With a conductor temperature of 90 Deg. C at the commencement	
i)	Conductor	KA
ii)	Screen	KA
iii)	Armour	KA
13	Conductor	
i)	Material & Grade	
ii)	Nominal cross – sectional area	sq.mm
iii)	No. of strands	
iv)	Diameter of each strand (Nominal)	mm
v)	Max. DC resistance of conductor at 20 Deg. C	ohm/km
vi)	Max. AC resistance of conductor at 90 Deg. C	ohm/km
14	Reactance of cable at normal frequency (Approx)	ohm/km
15	Electrostatic capacitance at normal frequency	mircofarads per km
16	Charging current	
17	Loss tangent at normal frequency at Uo	
18	Conductor screen	
i)	Material	
ii)	Nominal thickness	mm
19	XLPE Insulation	
i)	Composition	
ii)	Type of curing	
iii)	Thickness of insulation (nominal)	mm
iv)	Tolerance on thickness	mm
v)	Dielectric constant at normal frequency	
vi)	Specific insulation resistance at 20 deg. C	ohm/km
vii)	Min. Volume resistivity at 20 deg. C	
viii)	Min. volume resistivity at 90 deg. C	

ix)	Min. Tensile strength	kg/sq.cm
x)	Min. Elongation percentage at rapture	%
xi)	Identification of cores	
20	1.2/50 microsecond impulse wave withstand voltage	kVp
21	5 min. power frequency withstand voltage	kV
22	Max. Dielectric stress at the conductor	kV/cm
23	Max. Dielectric stress at the conductor screen	kV/cm
24	Insulation screen	
i)	Material	
ii)	Extruded/wrapped	
iii)	Nominal thickness	mm
iv)	Colour	
25	Metallic screen	
i)	Material / composition	
ii)	Nominal radial thickness / dia	
26	Nominal diameter over metallic screen	mm
27	Nominal radial clearance allowed under metal sheath	mm
28	Type and material of filler	
29	Armour	
i)	Material and type	
ii)	Dia	



**14. 10kVA 1-Phase, 16 KVA (1/ 3-Phase) & 25 KVA 3-Phase L.T. Distribution Box (with MCCBs)**

**1. SCOPE:**

This specification covers the design, manufacture, inspection, testing at manufacturer place and supply of L.T. Distribution Box with energy meter. Distribution Boxes shall be used for controlling the L.T. feeders from the L.T. side of Distribution Transformers. The system shall be A.C. 3phase, 4 wires, 433V or AC single phase 2 wire, 230V, 50 Hz with effectively grounded neutral.

**2. SERVICE CONDITIONS:**

The equipment to be supplied against this specification shall be suitable for satisfactory continuous operation under the climatic conditions of the State.

**3. SYSTEM DETAILS:**

Distribution Boxes are meant for metering, control and protection of Distribution Transformers with relevant parameters as under:

S.No.	Transformer Capacity kVA	Full Current Amps	Incoming Circuit Configuration	Outgoing Circuits Configuration
1	10 KVA (1-Phase)	43 Amp	45 A SPN MCCB	2 x 32A SP MCCB
2	16 KVA (1-Phase)	70 Amp	80 A SPN MCCB	2 x 50 A SP MCCB
3	16 KVA (3-Phase)	22 Amp	25 A TPN MCCB	6 x 16 A SP MCCB
4	25 KVA (3-Phase)	34 Amp	40 A TPN MCCB	6 x 25A SP MCCB

Each Distribution box shall have provision for fixing of three phase tri-vector energy meter/single phase meter for DT metering depending upon capacity and type of transformer, 1No. single pole Neutral (SPN)/Three Pole Neutral (TPN) MCCB at incoming and 2 & 6 Nos. single pole MCCB at outgoing circuit as per above table. Incoming and Outgoing MCCB shall be connected through insulated connectors. Cable from the Distribution Transformer shall be connected to the incoming MCCB through energy meter. Cables from the outgoing terminals of the incoming MCCB shall be connected respectively to the R-Y-B Phase and Neutral terminals of the insulated bus bars or insulated Multiple Outgoing Connectors. Cables from insulated bus bars or insulated Multiple Outgoing Connectors shall be connected to the outgoing MCCBs. Aluminium cable of 16mm<sup>2</sup> for 10 KVA / 16KVA and 35mm<sup>2</sup> for 25KVA transformer shall be used. Cable shall be fixed with bus bar or connectors with minimum two screws of size not less than M6. Insulation provided shall be such that no live part including the screws for holding the cable shall be accessible by hand/finger.

**4. MCCB:**

MCCB shall be of reputed make and shall confirm to latest IS. MCCB shall be of fixed rating type. MCCB shall have rated service short circuit breaking capacity of 10 KA at 0.4 P.F. (lag) with rated insulation voltage of 660 V. The time current characteristics of MCCB shall be as per the following details:

Multiple of normal Current Setting	Tripping Time
1.05	More than 2.5 hrs.
1.2	More than 10 minutes and less than 2 hrs.
1.3	Less than 30 minutes

1.4	Less than 10 minutes
Multiple of normal Current Setting	Tripping Time
2.5	Less than 1 minute
6.0	Less than 5 Seconds

For above test, the reference calibration temperature of the MCCB shall be 50°C.

**5. ENCLOSURE:**

- 5.1 The enclosure shall be made up of CRCA MS sheet of 18 SWG sheet thickness for 10/16KVA single phase and of 16SWG for 16/26KVA three phase. The manufacturing process of Box shall be Deep Drawn Process. No welding joints in the body / doors of box are permitted in Deep Drawn Process.
- 5.2 The inside dimensions of Distribution Box shall be 300 x 500 x 160mm for 10 &16 kVA single phase transformer and 1000 x 500 x 170 mm for 16 & 25 kVA three phase Transformer. However, the dimensions of the box is for reference only, internal clearance as per our requirement shall be strictly maintained. Overall dimensions of the box shall be such that the box will withstand temperature rise limits as per IS and Company's Specification and to have sufficient space for working during maintenance. The size of the box will depend on the size of Electrical components and other relevant provision made in IS:13947/(P1,2&3), IS 2086and IS:4237 with latest amendment if any. Adequate slope on the top of box (as shown in the drawing) shall be provided to drain out rainwater from the top. The body and door of enclosure shall be individually in one piece without any welding, except for fixing of the accessories like hinges, clamps, mounting clamps, bolts etc. which shall be spot welded or MIG welded only. The door of Distribution box shall be fixed on three tamper proof inside hinges not visible from outside. Hinges shall be welded from inside of the box and door shall be fixed with the two screws in each hinge. Hinges shall be made from 1.6mm MS sheet with hinge pin of diameter 3mm. The hinge pin shall have head on top so that it does not fall down during the normal usage. Base and door shall have flange / collars as shown in drawing. Collar of Base and door shall overlap by minimum 8mm. Rubber gasket shall be provided in between base and doors, such that it provides proper sealing between the door and base of box to avoid ingress of water. Degree of protection shall be **IP- 33** as per IS-13947 (amended up to date). Rubber Gasket shall be fixed with suitable adhesive. Two numbers 'U' shaped latch arrangement shall be provided to Seal the door with body for 10/16KVA single phase and three numbers 'U' shaped latch arrangement shall be provided for 16/25KVA three phase. 2.5mm & 8mm diameter hole shall be provided in U-shaped latch for sealing wires & padlock. Holes provided for sealing & padlock should be aligned when latch is in closed position. 'U' shaped latch arrangement shall be made from 1.6 mm thick MS sheet and shall be welded from inner side of the box. U-latch shall be joined with stainless steel rivet.
- 5.3 Viewing window opening of 80mm x 90mm shall be provided with toughened glass of 5mm thickness as shown in drawing. Size of glass shall be 100mm x 110mm. Glass shall be provided with a wraparound single piece rubber gasket (without joint) having minimum depth of 8mm made from good quality rubber so that it can withstand weather effect. Glass along with rubber gasket shall be fixed from inside of the door of distribution box with powder coated glass holder made of 20 SWG MS sheet without any welding joint and by draw process. Glass holder shall be fixed with minimum four welded screws & nuts from inside and not visible from outside.
- 5.4 Mounting arrangement of the meter shall be as shown in the drawing. It should be raised from the base of box by 15mm (minimum). It should be suitable for different makes of meters. Galvanized/Zinc Plated adjustable strip shall be provided on meter mounting arrangement for fixing of the meter. Three

- mounting MS screws, one for upper hanger (M4 threads x length 12mm) & two (M4 threads x 25 or 35mm length) in moving slotted flat shall be provided for fixing of the meter.
- 5.5 Two sets of Louvers (One set on each side) shall be provided. The perforated sheet of 20 SWG CRCA MS shall be welded from inside of the louvers.
- 5.6 The surface of the enclosure shall be properly Pre-treated / Phosphated in a 7-Tank process and shall be applied with a powder coating of about 40 micron thickness. The powder coating shall be of Light Admiralty Grey colour shade (IS-5:1993 Colour No. 697). Powder coating shall be suitable for outdoor use. Rating and Type of distribution box shall be printed or embossed on the door of the distribution box.
- 5.7 EC grade Aluminium Bus bars of 100mm<sup>2</sup> (minimum) for Phase and Neutral, capable of carrying full load current shall be provided. Bus bar shall be completely insulated such that no live part including screws are accessible by hand/finger after fixing of cables. Insulation shall be Fire retardant. Bus bars shall be isolated with respect to body.
- 5.8 Two earthing bolts of diameter 10mm and 25mm long shall be welded from inside of the box and shall be provided with 2 nuts & washer. Earth marking shall be duly embossed near the earth bolts. There shall be no powder coating on the earthing bolts.
- 5.9 One No. Incoming & 2 Nos. outgoing cable holes shall be provided as shown in drawing. Cable holes shall be provided with superior quality rubber cable glands of internal diameter 30mm. Rubber glands shall be made such that internal diameter of glands provided for cables should be closed with the rubber film of minimum 1mm thickness. Cable will go through the glands by piercing the film of the glands.
- 5.10 For mounting of box on pole, four holes shall be provided the back side of the box as shown in drawing.
- 5.11 Danger marking shall be provided on the box in red color.
- 5.12 Name of Utility and name of scheme i.e. DDUGJY shall be embossed on the distribution box.
- 5.13 Each distribution box shall be supplied with proper packing in 3 ply corrugated box.
- 5.14 Tolerance permissible on the overall dimensions of box shall be  $\pm 3\%$ .

**6. FINISHING OF DISTRIBUTION BOX:**

The surface of the box shall be properly pretreated / phosphated in 7-tank process and shall be applied with powder coating. The process facility shall be in house of the manufacturer to ensure proper quality for outdoor application.

**7. ACCEPTANCE TESTS :**

Following acceptance tests shall be carried out while inspecting lot of material offered.

**a. Visual Examination:**

The Distribution box shall be inspected visually, externally and internally for proper Powder Coating layer, fitting of all the components in accordance with technical Specification.

**b. Verification of dimensions:**

Verification of dimensions, external / internal clearances will be carried out as per technical specifications.

**c. Verification of fittings:**

Components like insulated bus bars, MCCBs, Hinges, Rubber Glands etc will be verified as per technical specification.

d. **High voltage withstand test at 2.5KV:**

The A.C. voltage of 2.5KV, 50HZ shall be applied for one minute as follows:

- i) Between Live Parts of each insulated bus bar
- ii) Between each insulated bus bar and earthing Screw/bolts
- iii) On bus bar insulation.
- iv) On PVC coating of PVC cables.

There shall not be any puncture or flash over during this test.

e. **MCCB:**

Time current characteristics of each rating of MCCB shall be checked as per the requirement of the specifications.

f. **Current Carrying Capacity:**

The current of 200 Amp shall be applied for 30 minutes through high current source on each insulated bus bar. There shall not be overheating of the insulated bus bars during this test.

**8. TESTING & MANUFACTURING FACILITIES:**

The Tenderer must clearly indicate what testing and manufacturing facilities are available in the works of manufacturer and whether the facilities are adequate to carry out all Routine & Acceptance Tests. These facilities should be available to inspection Engineers, if deputed to carry out or witness the tests in the manufacturer's works. The tenderer must have all the in-house testing facilities to carry out the acceptance tests on the Box.

**9. TESTS:**

The Distribution box shall comply with the requirement of IP33. Each type of LV Switchboard shall be completely assembled, wired, adjusted and tested at the factory as per the relevant standards and during manufacture and on completion.

**i) Routine Test**

The tests shall be carried out in accordance with IS 13947 and 8623 include including but not necessarily limited to the following:

- (a) Visual Check
- (b) Verification of Component Rating
- (c) Other Checks
  - i) Easy Accessibility and Maintenance
  - ii) Color Coding provided by colored tapes.
  - iii) Bus bar dimensions
  - iv) Degree of Protection check by paper.
- (d) Dimension check
- (e) Insulation Resistance Tests
- (f) Mechanical Operation Tests

- (g) Bus bar support and clearances
- (h) Continuity of circuits and Function
- (i) Powder Coating
- (j) Overload Release setting of the Circuit Breakers

**ii) Type Test**

The box shall be fully type tested as per the requirement of IS 13947 (Part-1):1993 with latest amendment. The type test shall be carried out from the Govt. approved laboratories duly accredited by National Board of Testing & Calibration Laboratories (NABL) of Govt. of India.

**10. Prototype & Drawings:-**

The manufacturer has to manufacture the prototype Unit for each rating as per this specification before bulk manufacturing. The manufacturer should intimate the readiness of prototype to employer. The Project Manager will inspect the prototype for approval. The manufacturer should submit the final drawings in line with this specification and prototype to employer for approval before bulk manufacturing. The approval of prototype & drawings shall be a responsibility of manufacturer/Contractor. Tentative drawing of box is enclosed herewith.

**20 63,100,200 & 315 kVA L.T. Distribution Box**

**1. SCOPE:**

This Specification covers the design, manufacture, testing at works and supply of Distribution Boxes made out of **CRCA MS** for controlling the L.T. feeders from the L.T. side of Distribution Transformers. The system shall be A.C. 3 phase, 4 wire, 433 V, 50 HZ with effectively grounded neutral.

**2. SERVICE CONDITIONS:**

The equipment to be supplied against this specification shall be suitable for satisfactory continuous operation under the tropical conditions as specified by employer which is as hereunder;

- 2.1 Maximum ambient temperature (Degree C)
- 2.2 Maximum temperature in shade (Degree C)
- 2.3 Minimum Temperature (Degree C)
- 2.4 Relative Humidity (percent)
- 2.5 Maximum Annual rain fall (mm)
- 2.6 Maximum wind pressure (kg/sq.m)
- 2.7 Maximum altitude above mean sea level ( Meter)
- 2.8 Isoceranic level (days per year)
- 2.9 Siesmic level (Horizontal Acceleration)

Moderately hot and humid tropical climate conducive to rust and fungus growth ....

**3. SYSTEM DETAILS:**

Distribution Boxes are meant for control and protection of Distribution Transformers with relevant parameters as under:-

S.N.	Particulars	Details			
		63 KVA	100 KVA	200 KVA	315 KVA
1.	KVA rating	63 KVA	100 KVA	200 KVA	315 KVA
2.	Voltage	433 V, 3 Ph, ( 3x 250 V)			
3.	Frequency	50 HZ			
4.	Phases	3 phase, solidly grounded neutral			
5.	Approximate full load current of transformer	84 A	133 A	270 A	440 A
6.	No. of Outgoing circuits	2 nos		3 nos	4 nos

**3.4 Applicable Standards:**

IS :13947/ (Part 3) (amended upto date) for Isolator (Switch Disconnecter)

IS: 13947/ (Part2)(amended upto date) for L.T. MCCBs.

IS: 8623 (amended upto date) for enclosure Box & for degree of protection provided by enclosures of electrical equipments.

IS: 4237, IS:8623 (amended upto date) – for general requirement of L.T. switchgears.

IS 13703 ( Part I & II amended upto date) for HRC Fuse Base and HRC Fuse Link.

IS: 5 /2007 - Colours of Ready Mixed paints and Enamels.

IS: 13871/1993 (amended upto date) – Powder coatings – specifications

IS : 6005/1998 (amended upto date) – Code of Practice for phosphating of iron and steel.

IS: 13411/1992 (amended upto date) – Glass Reinforced Polyester Dough Moulding Compounds

**3.5 MANUFACTURE/CONSTRUCTION OF BOXES:**

Distribution Boxes shall have Isolator (Switch Disconnecter) and HRC fuse base with links on incoming circuit and single pole MCCBs & Link Disconnecter on outgoing circuits with necessary interconnecting Bus Bars/ Links.

Standard General Arrangement of Isolators, HRC fuse base with links, MCCBs, Link Disconnecter, Neutral Links, Bus Bars, connecting links, Cable termination arrangement etc inside the Box is shown in the enclosed drawings.

**3.6 INCOMING CIRCUIT –**

**6.1 Isolator (Switch Disconnecter) -**

Each distribution box shall have one triple pole Isolator (Switch Disconnecter), conforming to relevant latest IS. The supplier shall indicate makes and types of offered isolator in GTP. The supplier shall submit Type Test Report of the Isolator as specified in Cl. No. 12.3 (II) for approval of Employer before commencement of supply. The Switch disconnecter to be provided in the Distribution Box will be as per Employer specification.

The Isolator should be front operated triple pole type. The casing of Isolator shall be of non-tracking, heat resistant insulating material of Dough Moulding Compound (DMC) of D<sub>3</sub> Grade as per IS:13411 (amended upto date), no separate enclosure is required. Isolator Base should withstand the breaking capacity of 80 kA. To extinguish the arc immediately in isolators, in each phase arc-chutes with minimum 12 strips shall be provided.

The isolator should be front operated triple pole type. The isolator shall be robust in construction and easy for operation. The handle of the isolator should be detachable easily for security purpose while working on L.T. circuits.

The characteristics of Isolator shall be as follows:

S.N.	Characteristics	Rating			
		63 KVA	100 KVA	200 KVA	315 KVA
1.	Basic uninterrupted duty	200 A		600A	
2.	Mechanism	Manual quick make quick break			
3.	Standard applicable	IS : 13947 amended upto date			
4.	Utilization category	AC –23 A			
5.	Mechanical Endurance	As per IS 13497 amended upto date			
6.	Electrical Endurance	As per IS: 13947 amended upto date			
7.	Rated Duty	Uninterrupted			
8	Making /Breaking capacity	Not less than requirement of AC –23 A category			
9.	Two seconds rating	4 KA		8 KA	
10.	Rated insulation voltage	660 V			

The terminal connector strips of the isolator shall be projecting out of isolator of 80 mm (minimum) in length on cable connection side and 60mm (minimum) on HRC fuse base side as shown

in the drawings. In 63 /100/200/315 KVA distribution box, the cross section of the strips on outside of the isolator shall be provided as below:

63/100 KVA -	25X5 mm.
200 KVA-	50X 6 mm
315 KVA-	50X 6 mm

The material of isolator strips shall be EC grade tin-plated copper. The terminal strips shall be continuous from the point of contact separation inside the Isolator with cross section as mentioned above throughout the length. Gap of 50mm shall be maintained between each terminal throughout the length.

**6.2 HRC FUSE**

HRC Fuse of suitable capacity shall be provided between outgoing terminal of Switch Disconnecter (Isolator) and incoming Busbar to facilitate electrical breaking of the circuit. Each Distribution Box shall have 3 Nos. of HRC Fuse Base with HRC Fuse Links (Blade type Contacts).

The supplier shall indicate in GTP, the make, type and capacity of HRC Fuse Base and Fuse Links offered.

**(i) HRC FUSE BASE**

The base of the HRC Fuse shall be of non-tracking, heat resistant insulating material of Dough Moulding Compound (DMC) of D<sub>3</sub> Grade as per IS:13411/1992. The Fuse Base shall be sturdy in construction.

The extension terminal connector strips of the Fuse Base shall be projecting out on both sides, made with two pieces ( half portion of the terminal contact and extension strip should be continuous in one piece), as shown in the drawing. The dimensions shall be as shown in the drawing. The material for both strips shall be tin plated EC Grade copper. HRC Fuse Base & fuse link should have withstand the breaking capacity of 80 kA.

HRC Fuse base shall be suitable for fuse of 200A for 63/100 KVA distribution box and 400 A for 200 KVA and 630A for 315 kVA distribution box.

**(ii) HRC FUSE LINK**

The HRC Fuse Links shall be sturdy in construction of "Din Type". Breaking Capacity shall be 80 kA. For fault indication red pop up indicator should come out instantly on fusing. Manufacturer's name, current rating, breaking capacity and type shall be marked on HRC fuse link.

HRC Fuse link Current rating for 63/100 /200/315 KVA distribution box shall be as follows:

63 KVA	- 100 A
100 KVA	- 160 A
200 KVA	- 315 A.
315 KVA	- 500 A

The supplier shall submit Type Test Report of the HRC fuse base and HRC fuse link as specified in Cl. No. 12.3 (III) for approval of Employer before commencement of supply. The HRC fuse base with links to be provided in the Distribution Box will be as per Employer approval given in the detailed purchase order.

**3.7 OUTGOING CIRCUITS:**

**(i) MCCBs**

Each distribution box shall have 6 nos. of single-pole MCCBs in 63 KVA /100 KVA Box, 9 nos of single-pole MCCBs in 200 KVA box and 12 nos of single-pole MCCBs in 315 KVA box to protect outgoing circuits. MCCB shall be of reputed make and shall confirm to latest IS. The supplier shall indicate the



makes and types of MCCBs offered in GTP. The supplier shall submit Type Test Report of the MCCB as specified in Cl. No. 12.3 (IV) for approval of Employer before commencement of supply. The MCCBs to be provided in the Distribution Box will be as per Employer approval as given in the detailed purchase order.

MCCB shall have quick make quick break mechanism. Making of MCCB shall only be manual but breaking of MCCBs shall be electrical as well as manual.

The detailed specification for MCCBs shall be as under.

S.No.	Particulars	Details			
		1.	KVA rating	63 KVA	100 KVA
2.	Rated current	150 A		200 A	
3.	Fixed overload release setting ( A)	60 A	90 A	120 A	120 A
4.	No. of poles	Single pole			
5.	Rated service short circuit breaking capacity ( kA) which is equal to ultimate breaking capacity as per IS 13947 (amended upto date)	10 KA at 0.4 p.f . ( lag)			
	The sequence of operation for this test shall be, O - t - CO - t - CO, and t = 3 min.). The test shall be done at 250V at 0.4 p.f. (lag). Voltage rating phase to phase 433 V and phase to earth 250V.				
6.	Power factor for short circuit (Max.)	0.4 lag			
7.	Utilization category	A			
8.	Rated Insulation Voltage	660 V			

The Busbar dropper and Terminal connection strip of Link Disconnecter shall be placed in contact terminal of MCCB as shown in the drawing.

The rated service short circuit breaking capacity as specified above, shall be based on the rated service short circuit test carried out at specified power factors.

To extinguish the arc immediately in MCCBs, arc-chutes with minimum 8 strips shall be provided.

While the above stipulation regarding the test power factor and the sequence of operation shall be binding, the other procedure for making the short circuit test and circuit etc. shall generally be in accordance with the Indian Standard applicable to the type of circuit breakers under test.

## 7.2 TIME CURRENT CHARACTERISTICS of MCCBs:

The L.T. MCCBs shall have time current characteristics as follows:

Multiple of normal Current setting	Tripping time
1.05	More than 2.5 hrs.
1.2	More than 10 minutes and less than 2 hrs.
1.3	Less than 30 minutes
1.4	Less than 10 minutes
2.5	Less than 1 minute
4.0	Not less than 2 seconds
6.0	Less than 5 seconds
12.0	Instantaneous (less than 40 milli seconds.)

For above time/current characteristic, the reference calibration temperature of the breaker shall be 50°C. Deration, if any, up to 60°C. Ambient temperature shall not exceed 10% of the current setting indicated above.

**c. LINK DISCONNECTOR :**

Link Disconnecter of 200 A capacity shall be provided between outgoing terminal of MCCB & cable connection to facilitate mechanical breaking (manual isolation) of the circuit. 63 /100 kVA Distribution Box shall have 6 Nos. of link Disconnectors, 200 kVA distribution box shall have 9 nos of link Disconnectors and 315 kVA distribution box shall have 12 nos of link Disconnectors.

The supplier has to indicate the makes and types of Link Disconnecter offered in GTP. The supplier shall submit Type Test Report of Link Disconnecter as specified in Cl.No. 12.3 (V) for approval of Employer before commencement of supply. The link Disconnectors to be provided in the Distribution Box will be as per EMPLOYER's approval as given in the detailed purchase order.

The base of the Link Disconnecter shall be of non-tracking, heat resistant insulating material of Dough Moulding Compound (DMC) of D<sub>3</sub> Grade as per IS:13411 (amended upto date). The Link Disconnecter shall be sturdy in construction and easy in operation.

The link of Link Disconnecter shall be of Tin-plated E.C. grade copper. The construction of the Link Disconnecter shall be such that it shall be hinged type on cable connection end and disconnectable at the MCCB end. The disconnection will be with the help of special handle/puller. One handle/puller shall be supplied alongwith each Distribution Box. The terminal connector strips of the Link Disconnecter of 25 x 3 mm cross section, shall be projecting out of Link disconnecter for minimum length of 80 mm. on cable connection side and 40 mm on MCCB outgoing side. The cross section of knife edge link shall be 20 x 5 mm. The material for both the strips and links shall be tin-plated E.C. grade copper. The size of bimetallic lugs hole & the hole on the disconnectors strip on cable side should be same.

**3.8 BUSBARS AND CONNECTIONS:**

The Incomer feeder should be on right side of the distribution box and all outgoing feeders will be on left side of the distribution box, with phase sequence RYB to be maintained. The phase busbars, incoming droppers and feeder droppers from busbars shall be of EC Grade Aluminium. The phase busbar strips shall be of size 25X8 mm for 63 KVA/100 KVA and 40X10 mm for 200 and 40X15 for 315 KVA box. Feeder droppers shall be 25X8 mm. Incomer dropper of 25 x 8 mm cross section for 63 /100 KVA box and 40 x 10 mm cross section for 200KVA box and 40X15 for 315 KVA box be provided. All busbars and droppers shall be properly drilled and de-burred. Each bus bar shall be of one single strip without any joint.

Busbars shall be provided with durable PVC insulating sleeves of standard colour code for different phases. Corrugated/Spring & Plain washers shall be used for Nut-Bolt connections.

Busbars shall be mounted on suitable size support insulators which should be tightened from inside. i.e. once fitted , should not be able to removed.

Minimum clearances, wherever shown, shall be as per General Arrangement Drawing enclosed with this specifications. Other clearances shall be as per requirement of IS: 4237 amended upto date.

**3.9 ENCLOSURE:**

- 9.1 The Box & Doors shall be made up of CRCA MS sheet of 2mm thickness.
- 9.2 The manufacturing process of Box shall be Deep Drawn process.
- 9.3 In case of Deep drawn type distribution boxes, the rounding of corners and slope on Top shall be as shown in the drawing. No joints in the body of the Box are permitted in Deep Drawn Process.
- 9.4 The welding process of distribution boxes shall be done by MIG (Metal Inert Gas) welding and workmanship/finishing should be good enough.

9.5 **For Deep Drawn Box:** the general clear dimensions of 63 / 100 KVA DistributionBox shall be 1000 x 1010 x 325 (LXHxW)mm. The center height of distribution box on front side shall be 1000 mm The general clear dimensions of 200 kVA distribution box shall be 1305 x 1050 x 325 (LXHxW) mm and for 315 kVA distribution box shall be 1545 x 1050 x 325 (LXHxW) mm. The center height of the distribution box on front side shall be 1050 mm

9.6 The Base and doors of enclosure shall be individually in one piece without any welding, except for fixing of the accessories like hinges, clamps, mounting clamps, bolts etc.

- A. 63/100 kVA boxes shall have two doors as shown in the drawing fixed on right & left side of the box with four hinges provided from inside of box. On closing of doors, right door shall rest on the left door. Hinges shall not be visible and approachable after closing the box.
- B. 200/315 kVA boxes shall have two doors as shown in drawing fixed on right side & left side of the box with four hinges on both sides shall be provided from inside of box. On closing of doors, right door shall rest on the left door. Hinges shall not be visible and approachable after closing the box.

Base and doors shall have flange / collars as shown in drawing. Collar of Base and doors shall overlap by 10mm. Rubber gasket of suitable size shall be provided in between base and doors, such that it provides proper sealing between the door and base of box to avoid penetration of dust & ingress of water. Degree of protection shall be **IP- 33** as per IS-8623 ( amended up to date ). Rubber Gasket shall be fixed with suitable adhesive. Four hinges on each side shall be provided from inside of the box to fix the doors. Hinges shall be minimum 50 mm in length & made from 2mm thick sheet. Hinge stainless steel pin diameter shall be 4mm. The hinges shall not be visible from outside.

9.7 The MCCBs, Link Disconnecter, Isolator and HRC fuse base with link shall be housed inside the enclosure. Isolator operating handle shall be accessible only after opening of the doors.

9.8 Four set of Louvers (two sets on each side) of suitable size shall be provided as shown in drawing. The louvers shall be provided such that heat dissipation is proper. The perforated sheet of 20 SWG with 2.5 mm holes shall be welded from inside of the louvers.

9.9 Mounting of components inside the enclosure shall allow free air circulation keeping the clearances as per drawings attached with specification.

9.10 **Locking Arrangement to the Box:**

The doors shall be closed with a push fit locking arrangement such that on pressing/pushing the right door, the distribution box gets locked from inside from top & bottom. This arrangement shall be operational for opening of the door with a handle provided outside the door. Handle shall be removable type only. A Nylon washer shall be provided between the handle and door to avoid penetration of water. One central lock with brass levers shall be provided inside the door. Key way shall be provided on the door for operating the central lock from outside. Key way shall be provided with cover.

9.11 A suitable cable termination arrangement with support insulators shall be provided on Isolators and Link Disconnectors. The bimetallic lugs of adequate size, as per enclosed specification & drawing, shall be provided. Clearances, Creepage and convenience in making connections shall be ensured.

9.12 EC grade Aluminium Neutral Busbar of 300 x 25 x 8 mm for 63/100 KVA box and 525 x 40 x 10 mm for 200 KVA and 40 x 15mm for 315 KVA Box capable of carrying for full load current. Neutral Busbar shall be isolated with respect to body. The bimetallic lugs of adequate size, as per enclosed specification & drawing, shall be provided. Neutral Busbar shall be as shown in the drawing attached with the specifications.

9.13 Bolts of M10 mm and 35 mm length with 2 Nos. plain washer and two Nos. nut are to be provided on both the sides for earthing of the distribution box. Earthing bolt is to be fixed on U-structure (Earth Clamp) welded on both sides of the distribution box. Thickness of earth clamp shall be 2mm. The top surface of the earth clamp shall be properly Zinc plated. Earthing nut bolt and washer should be zinc plated. There should be no powder coating on top surface of the earthing clamps.

- 9.14 Three bottom plates for 63/100 KVA and 4 bottom plates for 200 KVA and 5 bottom Plates for 315 KVA shall be provided for incoming and outgoing cables as shown in the drawing. Bottom plate of size 125mm x 125mm fixed with four screws from inside shall be provided for incoming and outgoing cables. Bottom plates shall be provided with suitable holes and rubber glands for the cables. Rubber glands shall be made such that internal diameter of glands provided for cables should be closed with the rubber film of minimum 1mm thickness. Cable will go through the glands by cutting the film of the glands. Bottom plates shall also be provided with cable clamps as shown in drawing.
- 9.15 Necessary fixing arrangement shall be provided at the back of the enclosure to ensure proper fixing on double pole structure by means of suitable clamps at 4 places.
- 9.16 Danger marking shall be provided in red colour on the right door of the distribution box. Marking shall be scratch proof and properly readable.
- 9.17 All the components inside the Box shall be mounted on CRCA MS strips of 2mm thickness. The mounting strips shall be provided with required bends or ribs to give the extra strength and shall be powder coated or zinc plated.
- 9.18 All joints of current carrying parts shall be bolted with 8.8 grade High Tensile MS Nuts & Bolts, Corrugated/spring & Plain Washers. The nuts & bolts should be of hexagonal type. All the nuts, bolts & washers should be properly zinc plated.
- 9.19 Each distribution box shall be supplied with proper packing in five ply - corrugated box.
- 9.20 Name plate having details such as Month & year of manufacturing, , Sr.No, and rating of Distribution box, XXXXX"Name of Employer" shall be riveted on the Distribution box door. Name of Manufacturer shall be duly embossed on the door of the distribution box. The name plate should be of stainless steel of thickness 1 mm.
- 9.21 Incoming and outgoing circuit should be duly highlighted with paint by stencil printing.
- 9.22 Adequate slope on the top of box shall be provided to drain out rainwater from the top.
- 9.23 3 Nos. MCCBs and 3 Nos. HRC fuse links in spare should be invariably provided with each box.
- 9.24 Good-quality plastic sticker leaflet should be pasted inside of distribution box door. The matter of instruction leaflet shall be provided by the employer. All the instructions in leaflet should be in Hindi/English/Local language.

**3.10 CABLE TERMINATION:**

Adequate size of Bimetallic lugs shall be provided for 3½ core, LT XLPE cable on incoming side and outgoing side for 63/100/200/315 KVA boxes as below :

	Incoming side	Outgoing Side
63 KVA	70 sq.mm	50/ 70 sq.mm
100 KVA	150 sq.mm	50/70 sq.mm
200 KVA	300 sq.mm	150 sq.mm.
315 KVA	300 sq.mm	150 sq.mm.

- 3.11 **LUG** : Bimetallic lug should be made for electrolytic grade aluminum. Each lug should be copper coated by electrolytic process and rich layer of tin should be mounted through out the lug to protect from Galvanic Corrosion. The lugs shall be such that the rich layer of tin should not peel of during operation. Individual lot should be pre filled with conductive inhibition compound and lug should be duly capped to prevent oozing of compound. The ductility of material should be such that flow ability of material be adequate to flow in to the strand of the conductor and withstand on crimping pressure of 8500 PSI. The cut cross section of the joints shall be homogeneous.

**3.12 FINISHING OF DISTRIBUTION BOX:**

The outer side and inside surface of the box shall be properly Pre-treated /Phosphated in seven tank process as per IS: 6005 and shall be applied powder coating of minimum 40 micron thickness. The Colour shade of light Admiralty gray (as per employer requirement) for 63, 100, 200 and 315 KVA box as per IS: 5/2007 (Colours of Ready Mixed paints and Enamels) shall be applied inside & outside surface of the box or as per state practice. Powder coating shall be suitable for outdoor use, conforming IS: 13871 (amended upto date) – Powder coatings. The process facility shall be in-house to ensure proper quality for outdoor application.

**3.13 TESTS & TEST CERTIFICATES:**

In case of bought out items, routine and acceptance tests as per relevant IS and this specification shall be carried out at the original manufacturers' works.

**a) Routine Test (Carried out on all boxes):**

- Overall Dimensions Checking.
- Insulation Resistance Tests.
- High Voltage Test at 2500 V, 50 Hz AC for one minute.

12.1.4. Operation Test on MCCB/Isolator/Link Disconnecter / HRC fuse base and fuse links.

**b) Acceptance Tests (on complete Distribution Box):**

Following tests shall be carried out as per acceptance tests in addition to routine tests on one random sample of each rating out of the lot offered for inspection:

- i) Temperature rise test on one sample of each rating.

Temperature rise test will be carried out as per the procedure given below:

For temperature rise test, a distribution box with all assembly of MCCBs / Link Disconnectors / Isolator / HRC fuse base with link shall be kept in an enclosure such that the temperature outside the box shall be maintained at 50 ° C.

20% more current than transformer secondary capacity i.e. for 63 KVA Distribution Transformers full load current 84A, 20 % more is 100 A shall be kept in incoming circuit keeping outgoing circuits short, till the temperature stabilizes and maximum temperature rise should be recorded.

- ii) Time-Current Characteristics

The MCCB should be tested for time current characteristics at 1.05 & 1.2 times of overload release setting current and should pass the requirement given in clause- 7.2.

**c) TYPE TESTS :**

**1 ON COMPLETE BOX:**

**a. Temperature rise test:-** The temperature rise test should be carried out as per IS: 8623

High voltage test shall be carried out as per IS:8623 amended upto date.

Short Time Withstand Current Test on Distribution Box shall be carried out as per IS 8623 or latest version.

The Distribution Box should be subjected to Short Time Withstand Current Test for 4KA for 2 seconds for 63/100 KVA Box and 8 KA for 2 second for 200/315 KVA box) all the circuits independently. The test should be carried out after by- passing MCCBs.

Degree of protection for **IP- 33** on complete box shall be carried out as per IS: 13947/1993 or the latest version thereof.

Time /current characteristic test on MCCBs shall be carried out as per clause **7.2** of this specification as stated above.

**2 ON ISOLATOR (SWITCH DISCONNECTOR):**

All type tests on Isolator (Switch Disconnecter) as per IS: 13947 (Part III) amended up to date shall be carried out.

**3 ON HRC fuses base and HRC fuse links :**

All type tests on HRC fuses and HRC fuse links IS 13703 ( Part I & II amended upto date) for HRC Fuse Base and HRC fuse link shall be carried out.

**4 ON MCCB:**

All type tests on MCCB as per IS-13947 amended upto date shall be carried out.

**5 ON Link Disconnecter:**

Following tests shall be carried out on link disconnecter as per IS:

- Short Circuit Withstand Strength
- Temperature rise Limits
- Mechanical Operations

**12.4 TYPE - TEST CERTIFICATES:**

The Distribution Box, Isolator (Switch Disconnecter), HRC fuse, HRC Fuse Link and MCCB offered shall be fully type tested as per relevant IS and this specification. The Supplier shall furnish detailed type test reports before commencement of supply. The detailed Type Test Reports shall be furnished with relevant oscillogram and certified Drawings of the equipment tested. The purchaser reserves the right to demand repetition of some or all the Type Tests in presence of purchaser's representative at purchaser's cost.

All the type tests shall be carried out from laboratories accredited by National Accreditation Board of Testing And Calibration Laboratories (NABL), Department of science & technology , Govt. of India to prove that the complete Box, Isolator, HRC fuse, Link Disconnecter & MCCB meet the requirements of the specification. The Manufacturer should also furnish certificate from laboratories that laboratories are having all the requisite test facility available in house. The type test Reports conducted in manufacturers own laboratory and certified by testing institute shall not be acceptable.

The Supplier should furnish the particulars giving specific required details of Distribution Boxes, MCCBs, Isolator and Link Disconnecter.

**3.14 TESTING & MANUFACTURING FACILITIES :**

Supplier must be an indigenous manufacturer. The Supplier must clearly indicate what testing facilities are available in the works of manufacturer and whether the facilities are adequate to carry out all Routine & Acceptance Tests. These facilities should be available to Employer's Engineers, if deputed to carry out or witness the tests in the manufacturer's works. The supplier must have all the in-house testing facilities to carry out the acceptance tests on the Box.

The supplier shall furnish detailed process of manufacturing & Powder coating.

**3.15 PROTOTYPE & DRAWINGS:-**

The manufacturer has to manufacturer the prototype Unit for each rating as per this specification before bulk manufacturing. The manufacturer should intimate the readiness of prototype to employer. The Project Manager will inspect the prototype for approval. The manufacturer should submit the final drawings in line with this specification and prototype to employer for approval before bulk manufacturing. The approval of prototype & drawings shall be a responsibility of manufacturer/Contractor. Tentative drawing of box is enclosed herewith.

**21 11kV Porcelain Insulators and Fittings**  
**Part-I : INSULATORS**

**1. SCOPE**

This specification covers details of porcelain insulators (Pin and Strain Insulators) for use on 11 KV overhead power lines in rural electric distribution system.

**2. APPLICABLE STANDARDS**

Except when it conflicts with the specific requirements of this specification, the insulators shall comply with IS:731 and IS:3188 as amended from time to time.

**3. GENERAL REQUIREMENTS**

- 3.1** The porcelain shall be sound, free from defects, thoroughly vitrified and smoothly glazed.
- 3.2** Unless otherwise specified, the glaze shall be brown in colour. The glaze shall cover all the porcelain parts of insulators except those areas which serve as support during firing or are left unglazed for the purpose of assembly.
- 3.3** The design of insulators shall be such that stresses due to expansion and contraction in any part of the insulator shall not lead to deterioration. The porcelain shall not engage directly with hard metal.
- 3.4** Cement used in construction of insulators shall not cause fracture by expansion or loosening by contraction and proper care shall be taken to locate the individual parts correctly during cementing. The cement shall not give rise to chemical reaction with metal fittings and its thickness shall be as uniform as possible.
- 3.5** The insulators should preferably be manufactured in automatic temperature - controlled kilns to obtain uniform baking and better electrical and mechanical properties.

**4. CLASSIFICATION AND DIMENSIONS**

- 4.1** Both pin and strain insulators shall conform to Type B of IS:731.
- 4.2** The dimensions of pin insulators shall be as shown in Fig. 1.
- 4.3** The strain insulators shall be of Ball and Socket type or Tongue and Clevis type, as required by the Purchaser. The dimensions of these insulators shall be as per Fig. 2.

**5. TEST VOLTAGES**

- 5.1** The test voltages of insulators shall be as under:

Highest System voltage	Visible Discharge Test	Wet Power Frequency withstand Test	Power Frequency puncture withstand test		Impulse voltage withstand Test
			Pin Insulator	Strain Insulator	
KV(rms)	KV(rms)	KV(rms)	KV(rms)	KV(rms)	KV(Peak)
12	9	35	105	1.3 times of the actual dry flash over voltage of the Insulator	75

**6. FAILING LOAD**

**6.1** Mechanical Failing Load (For Pin Insulators only) The insulators shall be suitable for a minimum failing load of 5 KN applied in transverse direction.

**6.2** Electro-Mechanical Failing Load (For Strain Insulators) The insulators shall be suitable for a minimum failing load of 45 KN applied axially.

**7. CREEPAGE DISTANCE**

The minimum creepage distance shall be as under :

Highest System Voltage	Normal and Moderately polluted atmosphere	Heavily Polluted atmosphere	
		Pin insulator	Strain insulator
KV	mm	mm	Mm
12	230	320	400

**Note :** Higher value of creepage distance has been specified for strain insulators as these are normally used in horizontal position in 11 KV lines.

**8. TESTS**

The insulators shall comply with the following tests as per IS:731 :-

**8.1 Type Tests**

- a) Visual examination
- b) Verification of dimensions
- c) Visible discharge test
- d) Impulse Voltage Withstand Test
- e) Wet Power Frequency Voltage Withstand Test
- f) Temperature cycle test



- g) Mechanical Failing load test (for Pin Insulators only) to be carried out as per procedure described at Sub-clause 8.4
- h) 24-hour Mechanical strength Test for Strain Insulators
- i) Puncture Test
- j) Porosity Test
- k) Galvanising Test
- l) Electro-mechanical failing load test (for Strain insulators only) to be carried out as per procedure described at Sub-clause 8.4.
- m) Thermal Mechanical Performance Test (for Strain insulators only) to be carried out as per procedure described at Sub-clause 8.4

**8.2 ROUTINE TESTS:**

- a) Visual examination
- b) Mechanical routine test (for strain insulator only)
- c) Electrical routine test (for strain insulator only)
- d) Hydraulic Internal Pressure test on shells for strain insulators to be carried out as per procedure described at Sub-clause 8.4

**8.3 ACCEPTANCE TEST:**

- a) Verification of Dimensions
- b) Temperature cycle Test
- c) Electro-mechanical failing load test (for strain insulators only) to be carried out as per procedure described at Sub-clause 8.4
- d) Puncture test (for strain insulators only)
- e) Porosity test
- f) Galvanising test

**8.4** Following procedure shall be used for conducting tests on insulators :

**1** Hydraulic Internal Pressure Test on Shells (For Disc Insulators)

The test shall be carried out on 100% shells before assembly. The detail and methodology for conducting this test has been illustrated at attached Annexure – 1.

**2** Thermal Mechanical Performance Test (if applicable)

Thermal Mechanical Performance Test shall be performed in accordance with IEC- 383-1-1993 Clause 20 with the following modifications:

- (1) The applied mechanical load during this test shall be 70% of the rated electromechanical or mechanical value.
- (2) The acceptance criteria shall be
  - (a)  $X$  greater than or equal to  $R + 3S$ .

Where

X- Mean value of the individual mechanical failing load.

R- Rated electro-mechanical / mechanical failing load.

S- Standard deviation.

(b) The minimum sample size shall be taken as 20 for disc insulator units.

(c) The individual electromechanical failing load shall be at least equal to the rated value. Also puncture shall not occur before the ultimate fracture.

**3 Electromechanical/Mechanical Failing Load Test.**

This test shall be performed in accordance with clause 18 and 19 of IEC 383 with the following acceptance

- (i) X greater than or equal to  $R + 3S$  , Where  
 X- Mean value of the electro-mechanical/mechanical/ failing load.  
 R- Rated electro-mechanical / mechanical failing load.  
 S- Standard deviation.
- (ii) The minimum sample size shall be taken as 20 for disc insulators units. However, for larger lot size, IEC 591 shall be applicable.
- (iii) The individual electro-mechanical/mechanical failing load shall be at least equal to the rated value. Also electrical puncture shall not occur before the ultimate fracture.

**9. MARKING**

**9.1** Each insulator shall be legibly and indelibly marked to show the following :

- a) Name or trade mark of manufacturer
- b) Month and year of manufacture
- c) Minimum failing load in KN
- d) ISI certification mark, if any

**9.1.1** Markings on porcelain shall be printed and shall be applied before firing.

**10. PACKING**

All insulators (without fittings) shall be packed in wooden crates suitable for easy but rough handling and acceptable for rail transport. Where more than one insulator is packed in a crate, wooden separators shall be fixed between the insulators to keep individual insulators in position without movement within the crate.

**11. INSPECTION**

**11.1** All tests and inspection shall be made at the place of manufacture unless otherwise especially agreed upon by the manufacturer and purchaser at the time of purchase. The manufacturer shall afford the inspector representing the purchaser all reasonable facilities, without charge, to satisfy him that the material is being furnished in accordance with this specification.

**11.2** The purchaser has the right to have the tests carried out at his own cost by an independent agency whenever there is dispute regarding the quality of supply.

**Part-II : INSULATOR FITTINGS**

**1. SCOPE**

This specification covers details and test requirements for (i) Pins for 11 KV Insulators, (ii) Helically Formed Pin Insulator Ties (iii) Fittings for Strain Insulators with Helically Formed Conductor Dead-Ends and (iv) Fittings for Strain Insulators with conventional Dead-End Clamps.

**2. APPLICABLE STANDARDS**

Pins shall comply with the requirements of IS:2486 (Pt.I & II). Helically formed fittings shall comply with IS:12048-1987. Fittings for strain insulators shall comply with the requirements of IS:2486Pt.I to IV.

**3. PINS FOR INSULATORS**

**3.1 General Requirements**

The pins shall be of single piece obtained preferably by the process of forging. They shall not be made by joining, welding, shrink fitting or any other process using more than one piece of material. The pins shall be of good finish, free from flaws and other defects. The finish of the collar shall be such that a sharp angle between the collar and the shank is avoided. All ferrous pins, nuts and washers, except those made of stainless steel, shall be galvanised. The threads of nuts and tapped holes, when cut after galvanising shall be well oiled or greased.

**3.2 Dimensions**

Pins shall be of small steel head type S 165 P as per IS:2486 (Part-II) having stalk length of 165mm and shank length of 150mm with minimum failing load of 5 KN. Details of the pins are shown in Fig. 3.

**3.3 Tests**

Insulator pins shall comply with the following test requirements as per IS:2486 (Part-I)-1993 or latest version thereof:

**3.3.1. Type Tests**

- a) Checking of threads on heads
- b) Galvanising test
- c) Visual examination test
- d) Mechanical test

**3.3.2 Acceptance Tests**

- a) Checking of threads on heads
- b) Galvanising test
- c) Mechanical test

**3.3.3 Routine Test**

Visual examination test

#### **4. HELICALLY FORMED PIN INSULATOR TIES**

**4.1** Helically formed ties used for holding the conductor on the pin insulator (Fig.4) shall be made of aluminium alloy or aluminised steel or aluminium-clad steel wires and shall conform to the requirements of IS:12048-1987.

**4.2** The ties shall be suitable for pin insulator dimensions as per Fig. 1 of Pt. I and conductor sizes to be specified by the purchaser.

**Note :** Helically formed insulators ties are made to suit specific sizes of conductors, which should be clearly specified by the purchaser.

**4.3** Elastomer pad for insulator shall be used with the ties to avoid abrasion of the conductor coming into direct contact with the insulator.

#### **4.4 Tests**

The ties shall be subjected to the tests specified in IS:12048-1987.

#### **5. FITTINGS FOR STRAIN INSULATORS WITH HELICALLY FORMED CONDUCTOR DEAD-ENDGRIPS**

##### **5.1 Fittings for Strain Insulators of Tongue & Clevis Type**

**5.1.1** The fittings shall consist of the following components:

- a) Cross arm strap conforming to IS: 2486 (Pt.II)-1989.
- b) Aluminium alloy die cast thimble-clevis for attaching to the tongue of strain insulator on one end and for accommodating the loop of the helically formed dead-end fitting at the other end in its smooth internal contour. The thimble shall be suitable for all sizes of conductors ranging from 7/2.11mm to 7/3.35mm ACSR. The thimble clevis shall be attached to the insulator by a steel cutter pin used with a non-ferrous split pin of brass or stainless steel. The thimble shall have clevis dimensions as per IS:2486 (Pt.II)-1989.
- c) Helically formed dead-end grip having a pre-fabricated loop to fit into the grooved contour of the thimble on one end and for application over the conductor at the other end. The formed fitting shall conform to the requirement of IS:12048-1987.

**Note :** As the helically formed fittings are made to suit specific sizes conductors, the purchase should clearly specify the number of fittings required for each size of conductor.

**5.1.2** Nominal dimensions of the T&C type insulator fittings are shown in Fig. 5.

##### **5.2 Fittings for Strain Insulators of Ball & Socket Type**

**5.2.1** The fittings shall consist of the following components:

- a) Cross arm strap conforming to IS:2486 (Pt.II)-1989.
- b) Forged steel ball eye for attaching the socket end of the strain insulator to the cross arm strap. Forgings shall be made of steel as per IS:2004-1978.

- c) Aluminium alloy thimble-socket made out of permanent mould cast, high strength aluminium alloy for attaching to the strain insulator on one end and for accommodating the loop of the helically formed dead-end fittings at the other end in its smooth internal contour. The thimble-socket shall be attached to the strain insulator with the help of locking pin as per the dimensions given in IS:2486 (Pt.II)-1989 and
- d) Helically formed dead-end grip as per clause 5.1.1(c) above.

**5.2.2** Nominal dimensions of the Ball & Socket type insulator fittings are shown in Fig. 6.

**5.3 Tests**

The helically formed fittings for strain insulators shall be subjected to tests as per IS:12048-1987. The other hardware fittings shall be tested as per IS:2486 (Part-I).

**6. FITTINGS FOR STRAIN INSULATORS WITH CONVENTIONAL DEAD-END CLAMPS ALTERNATIVE TO FITTINGS COVERED IN CLAUSE 5)**

**6.1** Fittings for strain insulators with conventional dead-end clamps for use with tongue & clevis or ball & socket type insulators shall consist of the following components :

- a) Cross arms strap conforming to IS:2486 (Pt.II)-1989
- b) Dead-end clamp made of aluminium alloy to suit ACSR conductors from 7/2.11mm to 7/3.35mm. The ultimate strength of the clamp shall not be less than 3000 Kg. The shape and major dimensions of clamps suitable for B&S and T&C insulators are shown in figures 7 & 8 respectively.

**6.2 Tests**

The fittings shall be subjected to type, routine and acceptance tests in accordance with the stipulations of IS:2486 (Pt.I).

**Note:** Fittings for strain insulators as stipulated in Clause 5 are preferable to the fittings stipulated in Clause 6 both from the point of view of better quality of construction and ease of application.

**7. PACKING**

**7.1** For packing of GI pins, strain clamps and related hardware, double gunny bags or wooden cases shall be used. The heads and threaded portions of pins and the fittings shall be properly protected against damage.

**7.2** The gross weight of the packing shall not normally exceed 50 Kg. Helically formed fittings shall be packed in card-board / wooden boxes. Fittings for different sizes of conductors shall be packed in different boxes and shall be complete with their minor accessories fitted in place and colour codes on tags/fittings shall be marked to identify suitability for different sizes of conductors as per IS:12048-1987.

**8 . INSPECTION**

**8.1** All tests and inspection shall be made at the place of manufacture unless otherwise especially agreed upon by the manufacturer and purchaser at the time of purchase. The manufacturer shall afford the inspector representing the purchaser all reasonable facilities, without charge, to satisfy him that the material is being furnished in accordance with this specification.

- 8.2 The purchaser has the right to have the test carried out at his own cost by an independent agency whenever there is dispute regarding the quality of supply.

**ANNEXURE-I**

**HYDRAULIC PRESSURE TEST ON DISC INSULATOR SHELL**

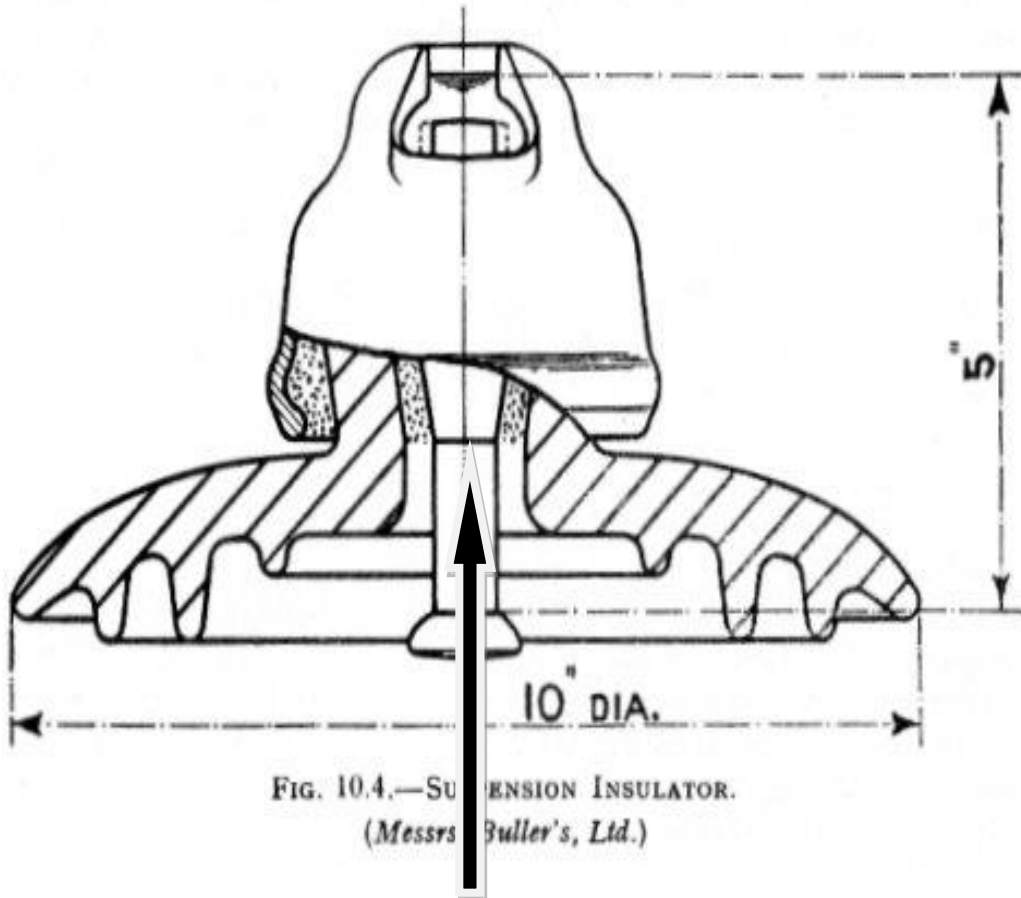

120 KG C/ M sq +/- 10 on the shell before cap and pin assembly to check the integrity of Porcelain

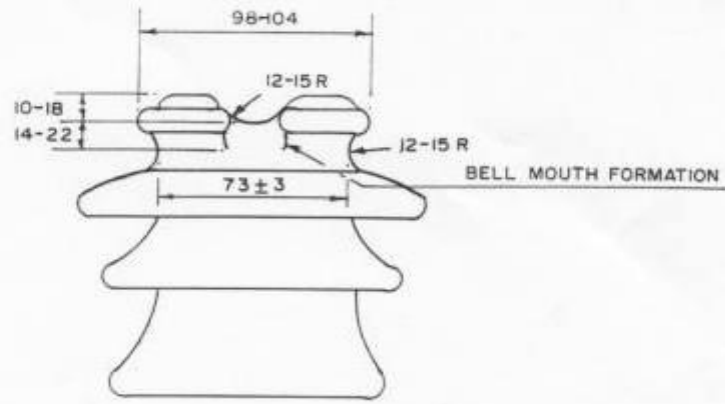

FIG-1.

११ के० वी० पिन विद्युत् रोधक का विस्तार  
 DIMENSIONS OF 11 KV. PIN INSULATOR

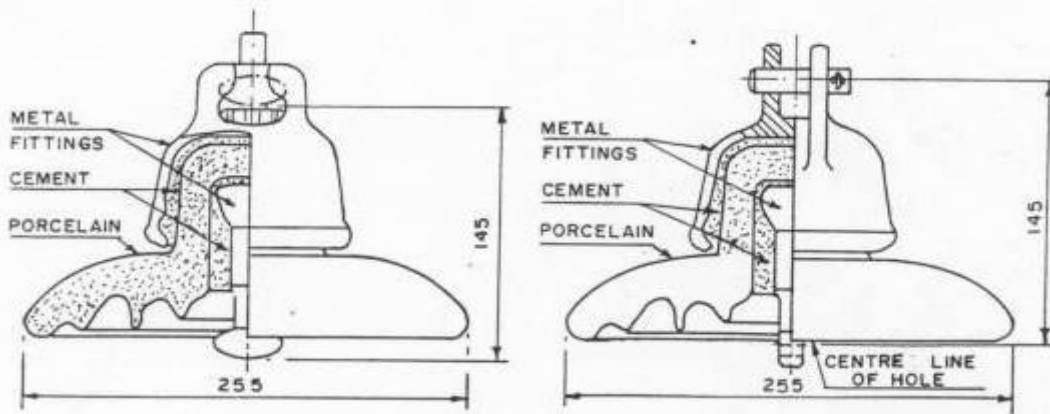
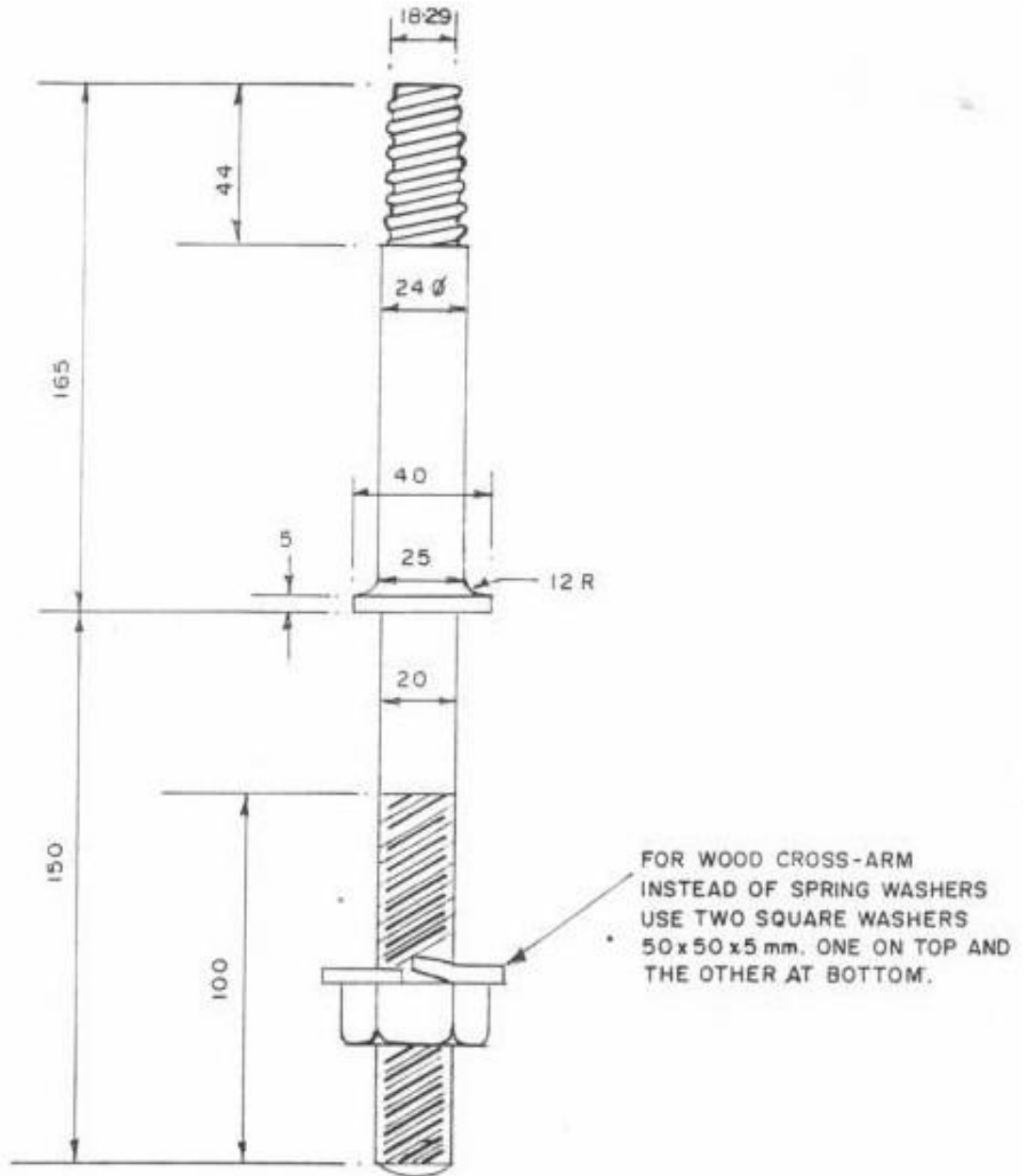

FIG-2A BALL AND SOCKET TYPE. FIG-2. TONGUE AND CLEVIS TYPE.

विकृत विद्युत् रोधक का विस्तार  
 DIMENSIONS OF STRAIN INSULATORS



विद्युत रोधक पिन  
INSULATOR PIN  
(TYPE S 165P)  
AS PER IS: 2486 Pt.II.

FIG-3.



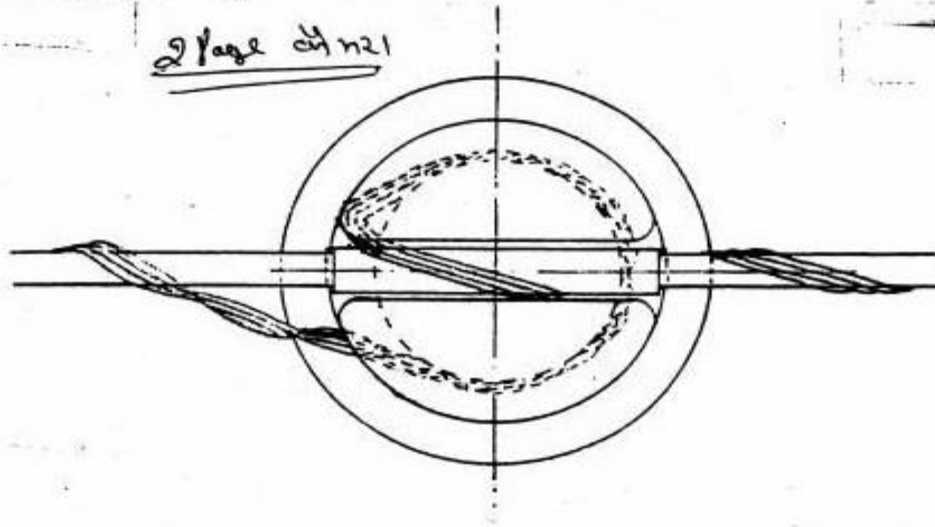

चित्र.४. ११ के. वी. पिन इन्सुलेटर टाई  
(सीधी और १०° तक कोणीय स्थिति के लिए उपयुक्त)

FIG:- 4 - 11 KV PIN INSULATOR TIE  
(SUITABLE FOR STRAIGHT RUNS AND ANGLE LOCATIONS UPTO 10°)

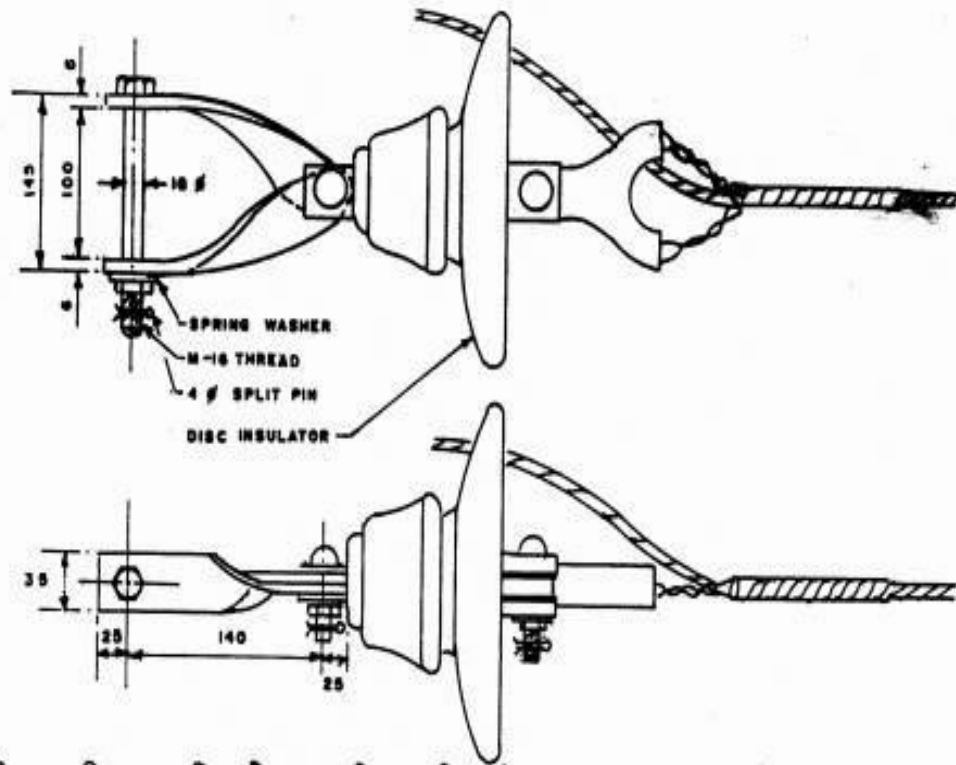

चित्र ५. टी. एण्ड सी. स्ट्रेन इन्सुलेटर एसेम्बली घुमावदार आकार फिटिंग सहित  
 FIG.5. T & C STRAIN INSULATOR ASSEMBLY WITH  
 HELICALLY FORMED FITTING

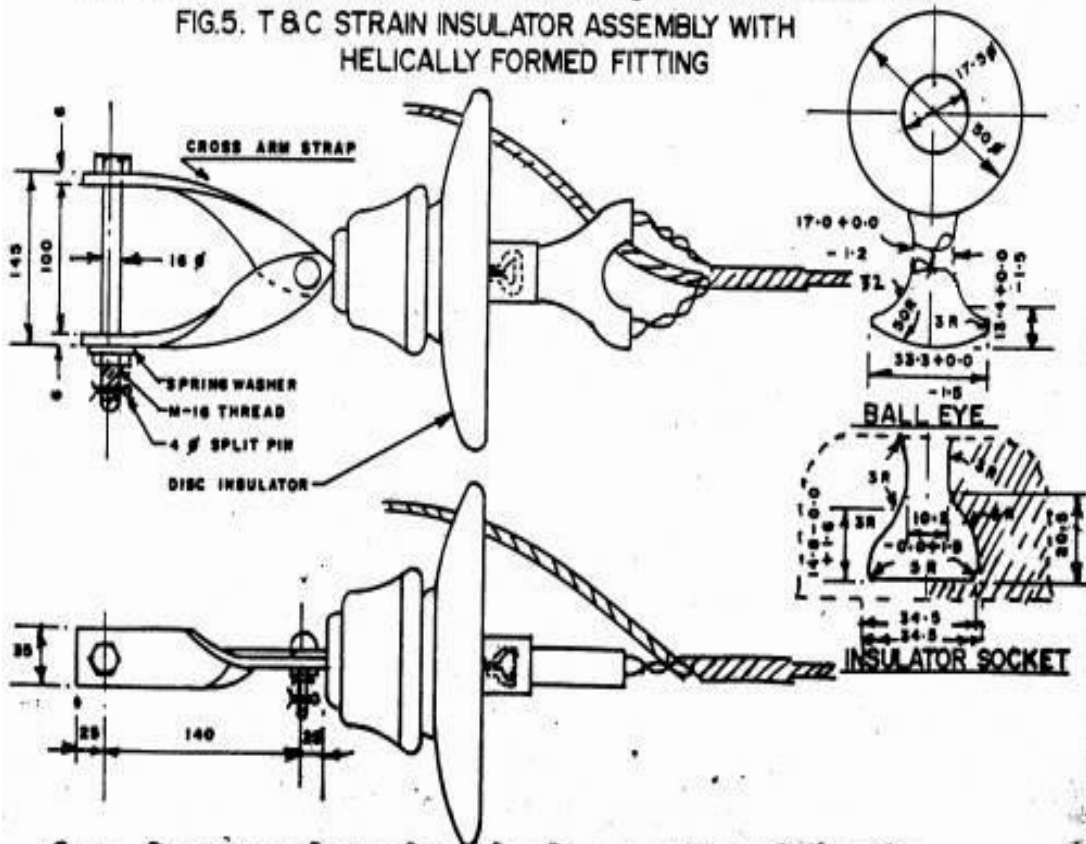

चित्र ६. बी. एण्ड एस. स्ट्रेन इन्सुलेटर एसेम्बली घुमावदार आकार फिटिंग सहित  
 FIG.6. B & S STRAIN INSULATOR ASSEMBLY WITH  
 HELICALLY FORMED FITTINGS

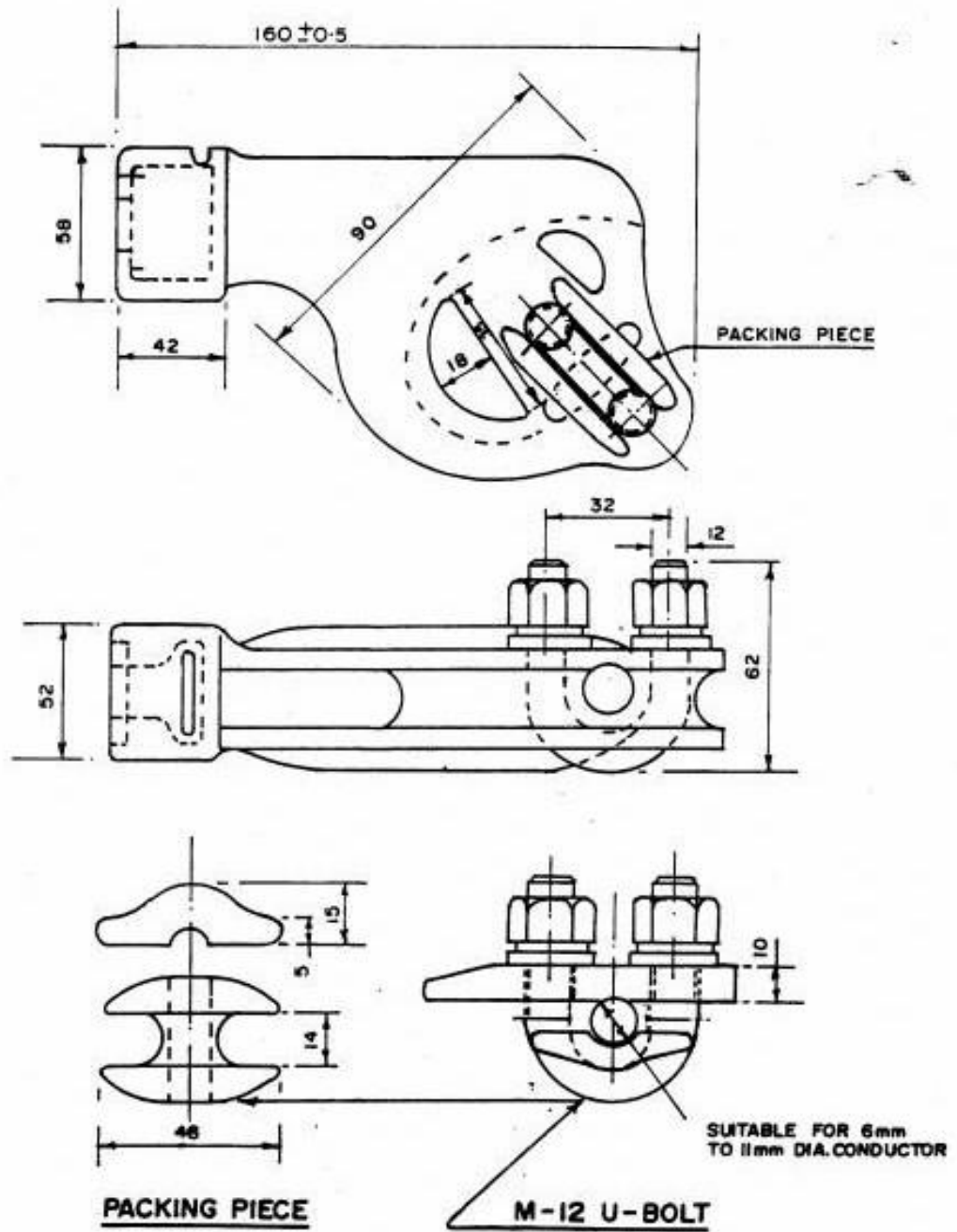

चित्र- 10. बॉल और सॉकेट प्रकार के विद्युत् रोधक के लिए एक की-विकृति (स्ट्रेन) क्लैम्प  
 FIG. 10 - 11KV. STRAIN CLAMP FOR BALL AND SOCKET TYPE INSULATOR.

ALL DIMENSIONS ARE IN mm.

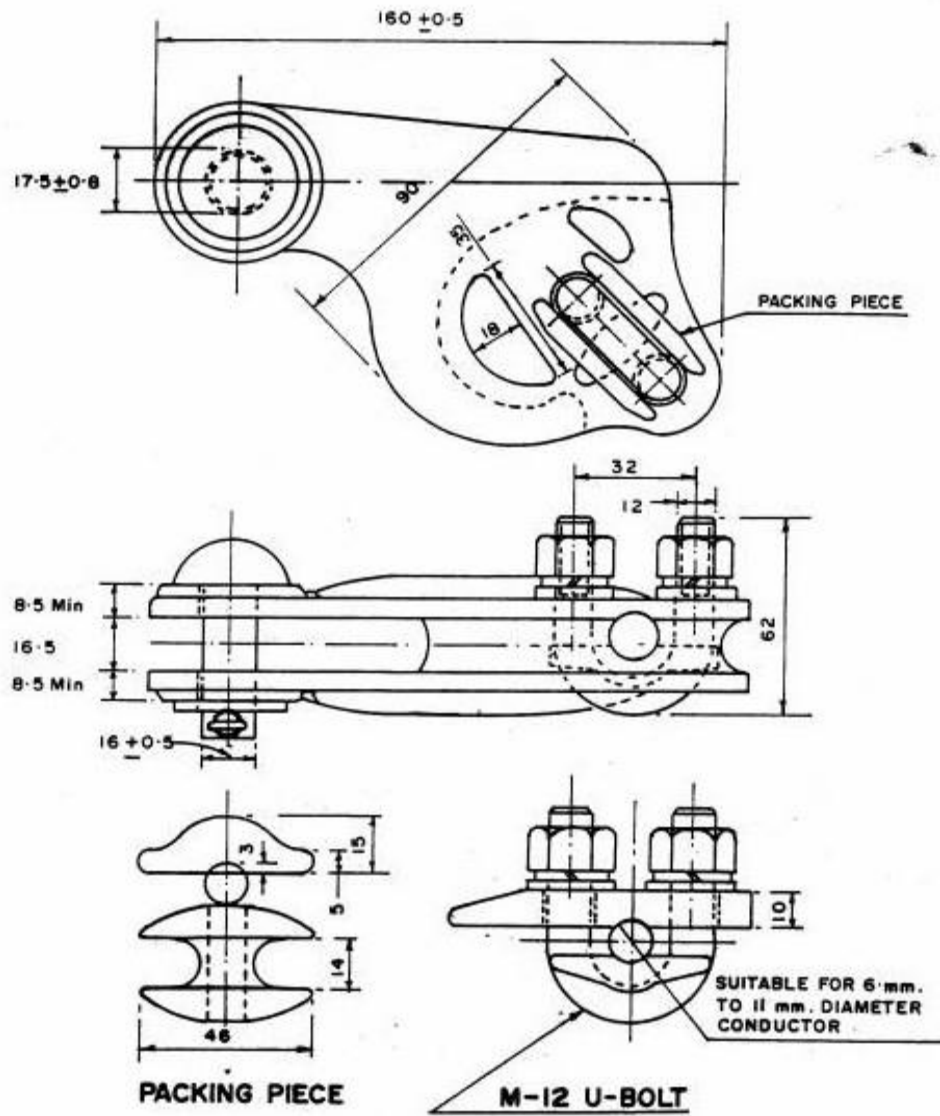

चित्र: ८. टंग और क्लेविज टाइप विद्युतरोधक के लिए ११ के. वी. विकृति क्लैम्प

FIG. 8. 11 KV. STRAIN CLAMP FOR TONGUE AND CLEVIS TYPE INSULATOR.

ALL DIMENSIONS ARE IN mm.

**22 Porcelain Insulators and Insulator Fittings for 33 kV Overhead Power Lines**

**1. SCOPE**

This specification covers the details of the porcelain insulators and insulator fittings for use on 33 KV lines in rural electric sub-transmission systems.

**2. APPLICABLE STANDARDS**

Unless otherwise stipulated in this Specification, the insulators shall comply with the Indian Standard Specification **IS:731-1971** and the insulator fittings with **IS:2486 (Pt.I)-1971 and IS:2486 (Pt.II)-1974** or the latest version thereof.

**3. INSULATORS**

**3.1 General Requirements**

- 3.1.1** The porcelain shall be sound, free from defects, thoroughly vitrified and smoothly glazed.
- 3.1.2** Unless otherwise specified, the glaze shall be brown in colour. The glaze shall cover all the porcelain parts of the insulator except those areas which serve as supports during firing or are left unglazed for the purpose of assembly.
- 3.1.3** The design of the insulator shall be such that stresses due to expansion and contraction in any part of the insulator shall not lead to deterioration. The porcelain shall not engage directly with hard metal.
- 3.1.4** Cement used in the construction of the insulator shall not cause fracture by expansion or loosening by contraction and proper care shall be taken to locate the individual parts correctly during cementing. The cement shall not give rise to chemical reaction with metal fittings, and its thickness shall be as uniform as possible.

**3.2 Classification**

- 3.2.1** Only Type 'B' insulators as defined in Indian Standards shall be used.
- 3.2.2** The string insulators shall only be of ball and socket type.

**3.3 Basic Insulation Levels**

- 3.3.1** The test voltages of the insulators shall be as under :

**Table (Clause 3.3.1)**

Highest System Voltage	Visible Discharge Test	Wet Power Frequency Withstand Test	Power Frequency Puncture Withstand Test		Impulse Voltage Withstand Test
			Pin	String Insulator Units	
KV (rms)	KV (rms)	KV (rms)	KV (rms)	KV(rms)	KV (Peak)
36	27	75	180	1.3 times the actual dry flash	170

				over voltage the Unit.	
--	--	--	--	---------------------------	--

**3.3.2** In this specification, power frequency voltages are expressed as peak values divided by  $\sqrt{2}$  and impulse voltages are expressed as peak values.

**3.3.3** The withstand and flashover voltages are referred to the 'Reference Atmospheric Conditions' as per Indian Standard.

**3.4 Mechanical Load**

The insulators shall be suitable for the minimum failing loads specified as under :

Pin Insulator Failing loads	String Insulator Units	
	Failing Loads	Commended Pin Ball Shank Diameter
10 KN	45 KN	16 mm

**3.5 Creepage Distance**

The minimum creepage distance shall be as under :

Highest System Voltage	Normal and Moderately Polluted Atmosphere (Total)	Heavily polluted Atmosphere (Total)
1	2	3
36KV	580mm	840mm

**Note :** For insulator used in an approximately vertical position the values given in Col.(2) or (3) shall apply. For insulators used in an approximately horizontal position, the value given in Col.(2) shall apply but the value in Col.(3) may be reduced by as much as 20%.

**3.6 Tests :**

The insulators shall comply with the following tests as per **IS:731-1971** and latest version thereof.

**3.6.1 Type Tests**

- a) Visual examination,
- b) Verification of dimensions,
- c) Visible discharge test,
- d) Impulse voltage withstand test,
- e) Wet power-frequency voltage withstand test,
- f) Temperature cycle test,
- g) Electro-mechanical failing load test

- h) Mechanical failing load test (for those of Type B string insulator units to which electro mechanical failing load test (g) is not applicable).
- i) Twenty four hours mechanical strength test (for string insulators only when specified by the purchaser.
- j) Puncture Test
- k) Porosity test and
- l) Galvanising test

### **3.6.2 Acceptance Tests**

The test samples after having withstood the routine tests shall be subjected to the following acceptance test in the order indicated below :

- a) Verification of dimensions.
- b) Temperature cycle test
- c) Twenty four hours mechanical strength test (for string insulator units only when specified by the purchaser)
- d) Electro-mechanical failing load test.
- e) Puncture test.
- f) Porosity test and
- g) Galvanising test

### **3.6.3 Routine Test**

- a) Visual examination.
- b) Mechanical routine test (for string insulator units only) and
- c) Electrical routine test (for string insulator units only)

## **3.7 Marking**

**3.7.1** Each insulator shall be legibly and indelibly marked to show the following :

- a) Name or trade mark of the manufacturer
- b) Month and year of manufacture
- c) Minimum failing load in Newtons
- d) Country of the manufacture and
- e) ISI Certification mark, if any.

**3.7.2** Marking on porcelain shall be printed and shall be applied before firing.

## **3.8 Packing**

All insulators (without fittings) shall be packed in wooden crates suitable for easy but rough handling and acceptable for rail transport. Where more than one insulator are packed in a crate, wooden separators shall be fixed between the insulators to keep individual insulators in position without movement within the crate. Disc insulators, however, may be assembled instring and packed inside a crate to prevent movement.

## **4. INSULATOR FITTINGS**

### **4.1 Pins for Pin Insulators**

#### **4.1.1 General Requirements**

**4.1.1.1** The pin shall be a single piece obtained preferably by the process of forging. It shall not be made by joining, welding, shrink-fitting or any other process from more than one piece of material. It shall be of good finish, free from flaws and other defects. The finish of the collar shall be such that a sharp angle between the collar and the shank is avoided.

**4.1.1.2** All ferrous pins, nuts and washer except those made of stainless steel shall be galvanised. The threads of nuts shall be cut after galvanising and shall be well oiled and greased.

#### **4.1.2 Type & Dimensions**

**4.1.2.1** Pins with large steel head Type L300N as per **IS:2486 (Pt.II)** having stalk length of 300 mm and shank length of 150 mm with minimum failing load of 10 KN shall be used.

**4.1.2.2** The complete details of the pin are given in Fig.1.

#### **4.1.3 Tests**

Insulator pins shall comply with the following tests as per **IS:2486 (pt.I)**.

##### **4.1.3.1 Type Tests**

- a) Visual examination test
- b) Checking of threads on heads
- c) Galvanising test and
- d) Mechanical test

##### **4.1.3.2 Acceptance Tests**

- a) Checking of threads on heads
- b) Galvanising test and
- c) Mechanical test

##### **4.1.3.3 Routine Test**

Visual examination

### **4.2 String Insulator Fittings**

#### **4.2.1 General Requirements**

**4.2.1.1** All forgings and castings shall be of good finish and free of flaws and other defects. The edges on the outside of fittings, such as at the ball socket and holes, shall be rounded.



**4.2.1.2** All parts of different fittings which provide for interconnection shall be made such that sufficient clearance is provided at the connection point to ensure free movement and suspension of the insulator string assembly. All ball and socket connections shall be free in this manner but care shall be taken that too much clearance between ball and socket is avoided.

**4.2.1.3** All ferrous fittings and the parts other than those of stainless steel, shall be galvanised. Small fittings like spring washers, nuts, etc. may be electro-galvanised.

**4.2.2. Type and Dimensions**

**4.2.2.1** Only ball and socket type insulator sets shall be used. The nominal dimensions of the ball and sockets, ball eye and cross-arm straps are given in Fig. 2. An assembly drawing of the complete insulator string is given in Fig. 3.

**4.2.2.2** Strain clamps shall be suitable for ACSR conductors 7/3.35 mm<sup>2</sup> (50 mm<sup>2</sup> Al. area), 7/4.09mm (80mm<sup>2</sup> Al. area) and 6/4.72mm + 7/1.57 mm (100 mm<sup>2</sup> Al. area). The ultimate strength of clamps shall not be less than 41 KN.

**4.2.3 Tests**

String insulator fittings shall comply with the following tests as per **IS:2486 (Pt.I)**.

**4.2.3.1 Type Tests**

- a) Slip strength test
- b) Mechanical test
- c) Electrical resistance test
- d) Heating cycle test
- e) Verification of dimensions
- f) Galvanising/Electroplating test, and
- g) Visual examination test

**4.2.3.2 Acceptance Tests**

- a) Verification of dimensions
- b) Galvanising/Electroplating test, and
- c) Mechanical tests

**4.2.3.3 Routine Tests**

- a) Visual examination test and
- b) Routine mechanical test

**4.2.4 Marking**

**4.2.4.1** The caps and clamps shall have marked on them the following :

- a) Name or trade mark of the manufacturer and
- b) Year of manufacture

### **4.3 Packing**

**4.3.1** For packing of GI pins, strain clamps and related hardware, double gunny bags (or wooden cases, if deemed necessary) shall be employed. The heads and threaded portions of pins and the fittings shall be properly protected against damage. The gross weight of each packing shall not normally exceed 50 Kg. Different fittings shall be packed in different bags or cases and shall be complete with their minor accessories fitted in place. All nuts shall be hand-tightened over the bolts and screwed upto the farthest point.

**4.3.2** The packages containing fittings may also be marked with the ISI certification mark.

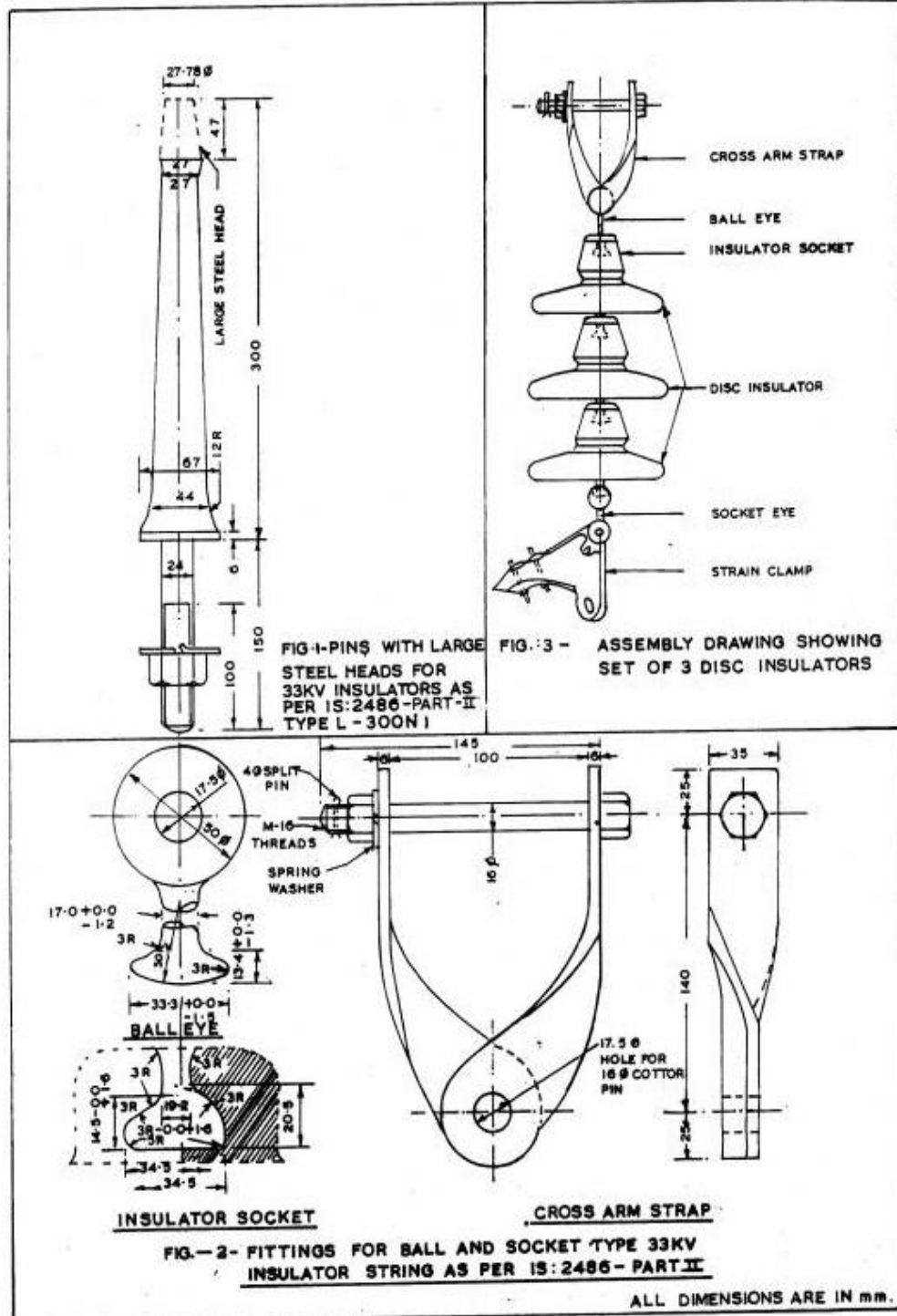

## **23 33 kV and 11 kV Post Insulator**

### **1 GENERAL REQUIREMENTS**

- I.** The porcelain shall be sound and free from defects, thoroughly vitrified and smoothly glazed.
- II.** Unless otherwise specified the glaze shall be brown in colour. The glaze shall cover all the exposed porcelain part of the insulator except those areas which serve as support or required to be left un-glazed.
- III.** Precaution shall be taken during design and manufacture to avoid the following:
- a) Stress due to expansion and contraction which may lead to deterioration .
  - b) Stress concentration due to direct engagement of the porcelain with the metal fittings.
  - c) Retention of water in the recesses of metal fitting and
  - d) Shapes which do not facilitate easy cleaning by normal methods.
- IV.** Cement used in the construction of the post insulator shall not cause fracture by expansion or loosening by contraction and proper care shall be taken to locate the individual parts correctly during cementing. Further, the cement shall not give rise to chemical reaction with metal fittings and its thickness shall be as uniform as possible.
- V.** All ferrous metal parts except those of stainless steel, shall be hot dip galvanized and the uniformity of zinc coating shall satisfy the requirements of IS : 2633. The parts shall be galvanized after mechanising . The finished galvanized surface shall be smooth.
- VI.** The threads of the tapped holes in the post insulators metal fittings shall be cut after giving anti- corrosion protection and shall be protected against rust by greasing or by other similar means. All other threads shall be cut before giving anti-corrosion protection. The tapped holes shall be suitable for bolts with threads having anti - corrosion protection and shall conform to IS : 4218(Part-I to VI). The effective length of thread shall not be less than the nominal diameter of the bolt.
- VII.** The post insulator unit shall be assembled in a suitable jig to ensure the correct positioning of the top and bottom metal fitting relative to one another. The faces of the metal fittings shall be parallel and at right angles to the axis of the insulator and the corresponding holes in the top and bottom metal fittings shall be in a vertical plane containing the axis of insulator.

### **2 CLASSIFICATION**

The post insulators shall be of type 'B' according to their construction, which is defined here under :

A post insulator or a post insulator unit in which the length of the shortest puncture path through solid insulating material is less than half the length of the shortest flash over path through air outside the insulator.

### **3 Standard insulation levels :**

- I.** The standard insulator levels of the post insulator or post insulator unit shall be as under :

Highest system voltage	Visible discharge test	Dry one minute power frequency withstand test.	Wet one minute power frequency withstand test.	Power frequency puncture withstand test.	Impulse voltage withstand test.
12 KV (rms)	9 KV(rms)	35 KV(rms)	35 KV(rms)	1.3 times the actual dry flash over voltage of the unit(KVrms)	75 KV peak
36 KV (rms)	27 KV(rms)	75 KV(rms)	75 KV(rms)	1.3 times the actual dry flash over voltage of the unit(KVrms)	170 KV peak

**II.** In this standard, power frequency are expressed as peak values divided by  $\sqrt{2}$ . The impulse voltages are expressed as peak values.

**III.** The withstand and flashover voltage are referred to the atmospheric condition.

**4 TESTS**

**I.** The insulators shall comply with the following constitute the type tests :

- a) Visual examination.
- b) Verification of dimensions.
- c) Visible discharge test.
- d) Impulse voltage withstand test.
- e) Dry power frequency voltage withstand test.
- f) Wet power frequency voltage withstand test.
- g) Temperature cycle tests.
- h) Mechanical strength tests.
- i) Puncture test.
- j) Porosity test.
- k) Galvanising test.

Type test certificates for the tests carried out on prototype of same specifications shall be enclosed with the tender and shall be subjected to the following acceptance test in the order indicated below.\

**II. Acceptance test:**

The test samples after having withstood routine test shall be subjected to the at least following acceptance test in the order indicated below :

- a) Verification of dimensions.
- b) Temperature cycle tests.
- c) Mechanical strength tests.
- d) Puncture test.
- e) Porosity test.
- f) Galvanising test.

**III. Routine tests:**

The following shall must be covered under routine tests on each post insulator or post insulator unit.

- a) Visual examination as per Cl. No.- 9.12 of IS : 2544/1973
- b) Mechanical routine test as per Cl. No.- 9.14 of IS : 2544/1973
- c) Electrical routine test as per Cl. No.- 9.13 of IS : 2544/1973

**5 MARKING**

**I.** Each post insulator shall be legibly and indelibly marked to show the following.

- a) Name or trade mark of the manufacturer.
- b) Month & year of manufacture.
- c) Country of manufacture.

**II.** Marking on porcelain shall be printed and shall be applied before firing.

**III.** Post insulator or post insulator units may also be mark with I.S.I. certification mark.

**6 PACKING**

All post insulators shall be pack in wooden crates suitable for easy but rough handling and acceptable for rail, transport. Where more than one insulator is packed in a crate wooden separators shall be fixed between the insulators to keep individual insulator in position without movement within the crate.

**Table-I**

Highest System Voltage in kV	Minimum Creepage distance in mm
	Post insulator
12	320
36	900

**ANNEXURE – A**

**1 Hydraulic Internal Pressure Test on Shells (if applicable)**

The test shall be carried out on 100% disc strain insulator shells before assembly. The details regarding test will be as discussed and mutually agreed to by the Contractor and Owner in Quality Assurance Programme.

**2 Thermal Mechanical Performance Test**

Thermal Mechanical Performance Test shall be performed in accordance with IEC-383-1-1993 Clause 20 with the following modifications:

(1) The applied mechanical load during this test shall be 70% of the rated electromechanical or mechanical value.

(2) The acceptance criteria shall be

(a)  $X$  greater than or equal to  $R + 3S$ .

Where,

- $X$  Mean value of the individual mechanical failing load.
- $R$  Rated electro-mechanical / mechanical failing load.
- $S$  Standard deviation.

(b) The minimum sample size shall be taken as 20 for disc insulator units.

(c) The individual electromechanical failing load shall be at least equal to the rated value. Also puncture shall not occur before the ultimate fracture.

**3 Electromechanical/Mechanical Failing Load Test.**

This test shall be performed in accordance with clause 18 and 19 of IEC 383 with the following acceptance

(i)  $X$  greater than or equal to  $R + 3S$

Where,

$X$  Mean value of the electro-mechanical/mechanical/ failing load.

$R$  Rated electro-mechanical / mechanical failing load.

$S$  Standard deviation.

(ii) The minimum sample size shall be taken as 20 for disc insulators units. However, for larger lot size, IEC 591 shall be applicable.

(iii) The individual electro-mechanical/mechanical failing load shall be at least equal to the rated value. Also electrical puncture shall not occur before the ultimate fracture.

4 **Chemical Analysis of Zinc used for Galvanizing**

Samples taken from the zinc ingot shall be chemically analysed as per IS:209. The purity of zinc shall not be less than 99.95%.

5 **Tests for Forgings**

The chemical analysis, hardness tests and magnetic particle inclusion test for forgings, will be as per the internationally recognised procedures for these tests. The sampling will be based on heat number and heat treatment batch. The details regarding test will be as discussed and mutually agreed to by the Contractor and Owner in Quality Assurance Programme.

6 **Tests on Castings**

The chemical analysis, mechanical and metallographic tests and magnetic particle inclusion for castings will be as per the internationally recognised procedures for these tests. The samplings will be based on heat number and heat treatment batch. The details regarding test will be as discussed and mutually agreed to by the Contractor and Owner in Quality Assurance Programme.



**24 11 kV/22 kV/33 kV Composite Insulators**

**1) SCOPE :**

This specification covers the design, manufacture, testing and supply of 11KV / 22KV / 33 KV Composite Insulators. The composite insulators shall be of the following type:

- i) Long rod insulators for conductors in tension application at angle / cut points the insulators shall be of tongue & clevis type.
- ii) Line post insulators or pin insulators for straight line locations

**2) SERVICE CONDITIONS :**

The insulators to be supplied against this specification shall be suitable for satisfactory continuous operation under the following tropical conditions.

Maximum ambient temperature (Degree C)	...	50
Minimum ambient temperature (Degree C)	...	3.5
Relative Humidity (%)	...	10 to 100
Maximum Annual Rainfall (mm)	...	1450
Maximum Wind pressure (kg/m.sq.)	...	150
Maximum wind velocity (km/hour)	...	45
Maximum altitude above mean sea level (meter)	...	1000
Isoceraunic level (days/year)	...	50
Seismic level (Horizontal acceleration)	...	0.3 g
Moderately hot and humid tropical climate Conductive to rust and fungus growth		

**3) SYSTEM PARTICULARS:**

a) Nominal System Voltage	11 kV	22 kV	33 kV
b) Corresponding highest system Voltage	12 kV	24kV	36 kV
c) Frequency	50 Hz with 3% tolerance		
d) Number of phase	3	3	3
e) Neutral earthing	effectively grounded.		

**4) STANDARDS :**

Unless otherwise specified elsewhere in the specifications insulators shall conform to the latest revisions of all relevant standards available at the time of placement of the order. The standards are listed in Annexure 'A'.

**5) GENERAL REQUIREMENTS**

- i) The composite insulators shall generally conform to latest Standards as listed in Annexure 'A'
- ii) The Composite Insulators will be used on lines on which the conductors will be A.A.A. Conductor of size up to 200 sq. mm. and ACSR of any size up to Panther (0.2 sq. inch copper equivalent). The insulators

should withstand the conductor tension, the reversible wind load as well as the high frequency vibrations due to wind.

- iii) Supplier must be an indigenous manufacturer and manufacturer of composite insulators of rating 33 kV or above OR must have developed proven in house technology and manufacturing process for composite insulators of above rating OR possess technical collaboration /association with a manufacturer of composite insulators of rating 33kV or above. The Manufacturer shall furnish necessary evidence in support of the above, which can be in the form of certification from the utilities concerned, or any other documents to the satisfaction of the Employer.
- iv) Insulator shall be suitable for both the suspension and strain type of load & shall be of tongue & clevis type. The diameter of Composite Insulator shall be less than 200 mm. The center-to-center distance between tongue & clevis shall be max. 300 mm for 11 kV, 450 mm for 22 kV & 550 mm for 33 kV composite Insulator.
- v) Insulators shall have sheds with good self-cleaning properties. Insulator shed profile, spacing, projection etc. and selection in respect of polluted conditions shall be generally in accordance with the recommendation of IEC-60815/IS: 13134.
- vi) The size of Composite insulator, minimum creepage distance and mechanical strength along with hardware fittings shall be as follows:

Sr. No.	Type of Composite insulators	Nominal System Voltage kV (rms)	Highest System Voltage kV(rms )	Visible Discharge Test Voltage kV(rms)	Wet Power Frequency Withstand Voltage kV(rms)	Impulse Withstand voltage kV(rms)	Minimum Creepage Distance (mm) (Heavily Polluted 25mm/kV)	Center to Center Distance Between Tongue & Clevis (mm)	Min. Failing load kN	Shed Diameter (mm) ( min)
i.	Long Rod Insulator	11	12	9	35	75	320	300	45	75-100
		22	24	18	55	125	600	450	70	100
		33	36	27	75	170	900	550	70	100
ii.	Post/Pin Insulator	11	12	9	35	75	320		5	
		22	24	18	55	125	560		10	
		33	36	27	75	170	900		10	

- vii) Dimensional Tolerance of Composite Insulators  
 The tolerances on all dimensions e.g. diameter, length and creepage distance shall be allowed as follows in line with-IEC 61109:  
 (0.04d+1.5) mm when d≤300mm.  
 (0.025d+6) mm when d>300 mm.  
 Where, d being the dimensions in millimeters for diameter, length or creepage distance as the case may be. However no negative tolerance shall be applicable to creepage distance.
- viii) Interchangeability:  
 The composite insulator together with the tongue & clevis fittings shall be of standard design suitable for use with the hardware of any other indigenous make conforming to relevant standards referred above.
- ix) Corona and RI Performance  
 All surfaces shall be clean, smooth, without cuts, abrasions or projections. No part shall be subjected to excessive localized pressure. The insulator and metal parts shall be so designed and manufactured that it shall avoid local corona formation and not generate any radio interference beyond specified limit under the operating conditions.

**6) TECHNICAL DESCRIPTION OF COMPOSITE INSULATORS**

Polymeric Insulators shall be designed to meet the high quality, safety and reliability and are capable of withstanding a wide range of environmental conditions.

Polymeric Insulators shall consist of THREE parts, at least two of which are insulating parts:-

- (a) Core- the internal insulating part
- (b) Housing- the external insulating part
- (c) Metal end fittings.

i) CORE

It shall be a glass-fiber reinforced epoxy resin rod of high strength (FRP rod). Glass fibers and resin shall be optimized in the FRP rod. Glass fibers shall be Boron free electrically corrosion resistant (ECR) glass fiber or Boron free E-Glass and shall exhibit both high electrical integrity and high resistance to acid corrosion. The matrix of the FRP rod shall be Hydrolysis resistant. The FRP rod shall be manufactured through Pultrusion process. The FRP rod shall be void free.

ii) HOUSING:

The FRP rod shall be covered by a seamless sheath of a silicone elastometric compound or silicone alloy compound of a thickness of 3mm minimum. It shall be one-piece housing using Injection Molding Principle to cover the core. The elastomer housing shall be designed to provide the necessary creepage distance and protection against environmental influences. Housing shall conform to the requirements of IEC 61109/92-93 with latest amendments

iii) WEATHERSHEDS

The composite polymer weather sheds made of a silicone elastometric compound or silicone alloy compound shall be firmly bonded to the sheath, vulcanized to the sheath or molded as part of the sheath and shall be free from imperfections It should protect the FRP rod against environmental influences, external pollution and humidity. The weather sheds should have silicon content of minimum 30% by weight. The strength of the weather shed to sheath interface shall be greater than the tearing strength of the polymer. The interface, if any, between sheds and sheath (housing) shall be free from voids.

iv) METAL END FITTINGS:

End fitting transmit the mechanical load to the core. They shall be made of spheroidal graphite cast iron, malleable cast iron or forged steel or aluminum alloy. They shall be connected to the rod by means of a controlled compression technique. Metal end fittings shall be suitable for tongue & clevis hard wares of respective specified mechanical load and shall be hot dip galvanized after, all fittings have been completed. The material used in fittings shall be corrosion resistant. As the main duty of the end fittings is the transfer of mechanical loads to the core the fittings should be properly attached to the core by a coaxial or hexagonal compression process & should not damage the individual fibers or crack the core. The gap between fitting and sheath shall be sealed by a flexible silicone elastomeric compound or silicone alloy compound sealant. System of attachment of end fitting to the rod shall provide superior sealing performance between housing, i.e. seamless sheath and metal connection. The sealing must be moisture proof. The dimensions of end fittings of insulators shall be in accordance with the standard dimensions stated in IEC: 60120/ IS: 2486 - Part-II /1989.

**7) WORKMANSHIP**

7.1 All the materials shall be of latest design and conform to the best engineering practices adopted in the high voltage field. Manufacturers shall offer only such insulators as are guaranteed by them to be satisfactory and suitable for continued good service in power transmission lines.

7.2 The design, manufacturing process and material control at various stages shall be such as to give maximum working load, highest mobility, best resistance to corrosion, good finish and elimination of sharp edges and corners.

- 7.3 The design of the insulators shall be such that stresses due to expansion and contraction in any part of the insulator shall not lead to deterioration.
- 7.4 The core shall be sound and free of cracks and voids that may adversely affect the insulators.
- 7.5 Weather sheds shall be uniform in quality. They shall be clean, sound, smooth and shall be free from defects and excessive flashing at parting lines.
- 7.6 End fittings shall be free from cracks, seams, shrinks, air holes and rough edges. End fittings should be effectively sealed to prevent moisture ingress; effectiveness of sealing system must be supported by test documents. All surfaces of the metal parts shall be perfectly smooth with out projecting points or irregularities, which may cause corona.

All load bearing surfaces shall be sooth and uniform so as to distribute the loading stresses uniformly.

- 7.7 All ferrous parts shall be hot dip galvanized to give a minimum average coating of zinc equivalent to 610 gm/sq.m. or 87 microm thickness and shall be in accordance with the requirement of IS:4759. the zinc used for galvanizing shall be of purity 99.5% as per IS:4699. The zinc coating shall be uniform, adherent, smooth, reasonably bright continuous and free from imperfections such as flux, ash rust stains, bulky white deposits and blisters. The galvanized metal parts shall be guaranteed to withstand at least four successive dips each lasting for one (1) minute duration under the standard preece test. The galvanizing shall be carried out only after any machining.

## **8) TESTS AND STANDARDS**

Insulators offered shall be manufactured with the same configuration & raw materials as used in the insulators for which design & type test reports are submitted. The manufacturer shall submit a certificate for the same. The design & type test reports submitted shall not be more than five years old.

### 8.1 DESIGN TESTS :

For polymeric insulators it is essential to carry out design test as per clause 4.1 of IEC 61109 / 92-93 with latest amendments. The design tests are intended to verify the suitability of the design, materials and method of manufacture (technology). When a composite insulator is submitted to the design tests, the result shall be considered valid for the whole class of insulators, which are represented by the one tested and having the following characteristics:

- Same materials for the core, and sheds and same manufacturing method;
- Same material of the fittings, the same design, the same method of attachment;
- Same or greater layer thickness of the shed material over the core (including a sheath where used );
- Same or smaller ratio of the highest system voltage to insulation length;
- Same or smaller ratio of all mechanical loads to the smallest core diameter between fittings
- Same or greater diameter of the core.

The tested composite insulators shall be identified by a drawing giving all the dimensions with the manufacturing tolerances.

Manufacturer should submit test reports for Design Tests as per IEC – 61109 (clause – 5). Additionally following tests shall be carried out or reports for the tests shall be submitted after award of contract:  
 UV test: the test shall be carried out in line with clause 7.2 of ANSI C29.13.

### 8.2 TYPE TESTS :

The type tests are intended to verify the main characteristics of a composite insulator. The type tests

shall be applied to composite insulators, the class of which has passed the design tests.

8.2.1 Following Type test shall be conducted on a suitable number of individual insulator units, components, materials or complete strings:

SI. No	Description of type test	Test procedure / standard
1	Dry lightning impulse withstand voltage test	As per IEC 61109(Clause 6.1)
2	Wet power frequency test	As per IEC 61109(Clause 6.2)
3	Mechanical load-time test	As per IEC 61109(Clause 6.4)
4	Radio interference test	As per IEC 61109(Clause 6.5) revised
5	Recovery of Hydrophobicity test	Annexure – B This test may be repeated every 3yrs by the manufacturer
6	Chemical composition test for silicon content	Annexure – B Or any other test method acceptable to the Employer
7	Brittle fracture resistance test	Annexure – B

The Manufacturer shall submit type test reports as per IEC 61109. Additional type tests required if any shall be carried out by the manufacturer, after award of contract for which no additional charges shall be payable. In case, the tests have already been carried out, the manufacturer shall submit reports for the same.

8.3 ACCEPTANCE TESTS :

The test samples after having withstood the routine test shall be subject to the following acceptance tests in order indicated below:

(a)	Verification of dimensions	: Clause 7.2 IEC: 61109,
(b)	Verification of the locking system (if applicable)	: Clause 7.3 IEC: 61109,
(c)	Verification of tightness of the interface Between end fittings & Insulator housing	: Clause 7.4 IEC: 61109 amendment 1of 1995
(d)	Verification of the specified mechanical load	: Clause 7.4 IEC: 61109, amendment 1of 1995
(e)	Galvanizing test	: IS:2633/IS:6745

8.4 ROUTINE TESTS:

Sr.No.	Description	Standard
1	Identification of marking	As per IEC: 61109 Clause 8.1
2	Visual Inspection	As per IEC: 61109 Clause 8.2
3	Mechanical routine test	As per IEC: 61109 Clause 8.3

Every polymeric insulator shall withstand mechanical routine test at ambient temperature tensile load at RTL corresponding to at least 50 % of the SML for at least 10 sec.

8.5 TESTS DURING MANUFACTURE:

Following tests shall also be carried out on all components as applicable

- (a) Chemical analysis of zinc used for galvanizing
- (b) Chemical analysis, mechanical, metallographic test and magnetic particle inspection for malleable castings.
- (c) Chemical analysis, hardness tests and magnetic particle inspection for forgings.

8.6 SAMPLE BATCH FOR TYPE TESTING :

The Manufacturer shall offer material for sample selection for type testing only after getting Quality Assurance Plan approved by Employer. The sample for type testing will be manufactured strictly in accordance with the approved Quality Assurance Plan.

**9) QUALITY ASSURANCE PLAN :**

9.1 The Manufacturer shall submit following information:

- i) Test certificates of the raw materials and bought out accessories.
- ii) Statement giving list of important raw material, their grades along with names of sub-Manufacturers for raw materials, list of standards according to which the raw materials are tested. List of tests normally carried out on raw materials in presence of Manufacturer's representative.
- iii) List of manufacturing facilities available.
- iv) Level of automation achieved and lists of areas where manual processing exists.
- v) List of areas in manufacturing process, where stage inspections are normally carried out for quality control and details of such tests and inspections.
- vi) List of testing equipments available with the Manufacturer for final testing of equipment along with valid calibration reports.
- vii) The manufacturer shall submit Manufacturing Quality Assurance Plan (QAP) for approval & the same shall be followed during manufacture and testing.

9.2 The Manufacturer shall submit the routine test certificates of bought out raw materials/accessories and central excise passes for raw material at the time of inspection.

9.3 The Employer's representative shall at all times be entitled to have access to the works and all places of manufacture, where insulator, and its component parts shall be manufactured and the representatives shall have full facilities for unrestricted inspection of the Manufacturer's and sub-Manufacturer's works, raw materials, manufacture of the material and for conducting necessary test as detailed herein.

9.4 The material for final inspection shall be offered by the Manufacturer only under packed condition. The Employer shall select samples at random from the packed lot for carrying out acceptance tests. The lot offered for inspection shall be homogeneous and shall contain insulators manufactured in 3-4 consecutive weeks.

9.5 The Manufacturer shall keep the Employer informed in advance of the time of starting and the progress of manufacture of material in their various stages so that arrangements could be made for inspection.

9.6 No material shall be dispatched from its point of manufacture before it has been satisfactorily inspected and tested unless the Employer in writing waives off the inspection. In the later case also the material shall be dispatched only after satisfactory testing specified herein has been completed.

9.7 The acceptance of any quantity of material shall in no way relieve the Manufacturer of his responsibility for meeting all the requirements of the specification and shall not prevent subsequent rejection, if such material are later found to be defective

**10) TEST CERTIFICATE :**

The manufacturer shall furnish detailed type test reports of the offered composite Insulators as per clause 8.2 of the Technical Specifications at the NABL approved laboratories to prove that the composite Insulators offered meet the requirements of the specification. These Type Tests should have been carried out within five years prior to the date of opening of this manufacturer

The Employer reserves right to demand repetition of some or all the Type Test in presence of Employer's representative. For this purpose, the manufacturer shall quote unit rates for carrying out each Type Test. However, such unit rates will not be considered for evaluation of the offer. In case the unit fails in the Type Tests, the complete supply shall be rejected.

**11) TESTING FACILITIES :**

The manufacturer must clearly indicate what testing facilities are available in the works of the manufacturer and whether facilities are adequate to carry out all Routine & acceptance Tests. These facilities should be available to Employer's Engineers if deputed or carry out or witness the tests in the manufacturer works. The insulators shall be tested in accordance with the procedure detailed in IEC 61109 / 92-93 with latest amendments.

**12) DRAWINGS :**

- (i) The Manufacturer shall furnish full description and illustration of the material offered.
- (ii) The Manufacturer shall furnish the outline drawing (3 copies) of each insulator unit including a cross sectional view of the long rod insulator unit. The drawing shall include but not be limited to the following information:
  - Long rod diameter with manufacturing tolerances
  - Minimum Creepage distance with positive tolerance
  - Protected creepage distance
  - Eccentricity of the long rod unit
    - Axial run out
    - Radial run out
  - Unit mechanical and electrical characteristics
  - Size and weight of ball and socket/tongue & clevis
  - Weight of composite long rod units
  - Materials
  - Identification mark
  - Manufacturer's catalogue number
- (iii) After placement of award the Manufacturer shall submit fully dimensioned insulator crate drawing for different type of insulators for approval of the Employer.

**13) RETEST AND REJECTION:**

13.1 Sample Procedure for testing of insulators shall be as per clause 7.1 to 7.6 of IEC 61109 for Acceptance

& Routine Tests.

For the sampling tests, two samples are used, E1 and E2. The sizes of these samples are indicated in the table below.

Lot Size (N)	Sample Size	
	E1	E2
N < 300	Subject to agreement	
300 < N < 2000	4	3
2000 < N < 5000	8	4
5000 < N < 10000	12	6

If more than 10000 insulators are concerned, they shall be divided into an optimum number of lots comprising between 2000 and 10000 insulators. The results of the tests shall be evaluated separately for each lot.

The insulators shall be selected by the Employer's representative from the lot at random.

The samples shall be subjected to the applicable sampling tests.

The sampling tests are:

- Verification of dimensions - (E1 + E2)
- Verification of the locking system - (E2)
- Verification of tightness of the interface between end fittings & Insulator housing - (E2)
- Verification of the specified mechanical load SML - (E1)
- Galvanizing test - (E2)

In the event of a failure of the sample to satisfy a test, the retesting procedure shall be as follows :

If only one insulator or metal part fails to comply with the sampling tests, a new sample equal to twice the quantity originally submitted to the tests shall be subjected to retesting. The retesting shall comprise the test in which failure occurs. If two or more insulator or metal parts fail to comply with any of the sampling tests or if any failure occurs during the retesting, the complete lot is considered as not complying with this standard and shall be withdrawn by the manufacturer.

Provided the cause of the failure can be clearly identified, the manufacturer may sort the lot to eliminate all the insulators with these defects. The sorted lot then be resubmitted for testing. The number then selected shall be three times the first chosen quantity for tests. If any insulators fail during this retesting, the complete lot is considered as not complying with this standard and shall be withdrawn by the manufacturer.

13.2 Verification of dimensions (E1 + E2)

The dimensions given in the drawings shall be verified. The tolerances given in the drawing are valid. If no tolerances are given in the drawings the values mentioned in this specification shall hold good.

13.3 Verification of the locking system (E2)

This test applies only to the insulators equipped with socket coupling as specified by IEC 120 and is performed according to IEC 383.

13.4 Verification of tightness of the interface between end fittings & Insulator housing (E2)



One insulator selected randomly from the sample E2, shall be subjected to crack indication by dye penetration, in accordance with ISO 3452, on the housing in the zone embracing the complete length of the interface between the housing and metal fitting and including an additional area, sufficiently extended beyond the end of the metal part.

The indication shall be performed in the following way.

- (i) the surface shall be properly pre-cleaned with the cleaner ;
- (ii) the penetrant, which shall act during 20 minutes, shall be applied on the cleaned surface;
- (iii) within 5 minutes after the application of the penetrant, the insulator shall be subjected, at the ambient temperature, to a tensile load of 70 % of the SML, applied between the metal fittings; the tensile load shall be increased rapidly but smoothly from zero up to 70 % of the SML, and then maintained at this value for 1 minute;
- (iv) the surface shall be cleaned with the excess penetrant removed, and dried;
- (v) the developer shall be applied if necessary;
- (vi) the surface shall be inspected.

Some housing materials may be penetrated by the penetrant. In such cases evidence shall be provided to validate the interpretation of the results.

After the 1 min. test at 70 % of the SML, if any cracks occur, the housing and, if necessary, the metal fittings and the core shall be cut, perpendicularly to the crack in the middle of the widest of the indicated cracks, into two halves. The surface of the two halves shall then be investigated for the depth of the cracks.

**13.5 Verification of the specified mechanical load SML**

The insulators of the sample E1 shall be subjected at ambient temperature to a tensile load, applied between the couplings. The tensile load shall be increased rapidly but smoothly from zero to approximately 75 % of the SML, and then be gradually increased to the SML in a time between 30 sec. to 90 sec.

If 100 % of the SML is reached in less than 90 s, the load (100 % of the SML) shall be maintained for the remainder of the 90 s. (This test is considered to be equivalent to a 1min withstand test at the SML.)

The insulators have passed the test at 13.4 & 13.5 above if:

No failure (breakage or complete pull out of the core, or fracture of the metal fitting) occurs either during the 1 min. 70 % withstand test (a) or during the 1 min. 100 % withstand test (b).

No cracks are indicated after the dye penetration method described in 13.4 above.

The investigation of the halves described in 13.4 above shows clearly that the cracks do not reach the core.

**13.6 Galvanizing test**

This test shall be performed according to IS: 2633/IS: 6745 on galvanized parts.

**14) MARKINGS :**

**14.1 Each insulator shall be legibly and indelibly marked with the following details as per IEC- 61109:**

- a) Name or trademark of the manufacturer.
- b) Voltage & Type
- c) Month and year of manufacturing.
- d) Min. failing load/guaranteed mechanical strength in kilo Newton followed by the word 'KN' to facilitate easy identification.
- e) DDUGJY 'Employer Name'. Marking

**14.2 One 10 mm thick ring or 20 mm thick spot of suitable quality of paint shall be marked on the end fitting of each composite long rod of particular strength for easy identification. The paint shall not have any deteriorating effect on the insulator performance.**

Following codes shall be used as identification mark:

For 45 KN long rod units : Blue  
For 70 KN long rod units : Red

**15) PACKING :**

- 15.1 All insulators shall be packed in strong corrugated box of min. 7 ply duly palletted or wooden crates. The gross weight of the crates along with the material shall not normally exceed 100 Kg to avoid hackling problem. The crates shall be suitable for outdoor storage under wet climate during rainy season.
- 15.2 The packing shall be of sufficient strength to withstand rough handling during transit, storage at site and subsequent handling in the field.
- 15.3 Suitable cushioning, protective padding, or Dunn age or spacers shall be provided to prevent damage or deformation during transit and handling.
- 15.4 All packing cases shall be marked legibly and correctly so as to ensure safe arrival at their destination and to avoid the possibility of goods being lost or wrongly dispatched on account of faulty packing and faulty or illegible markings. Each wooden case /crate /corrugated box shall have all the markings stenciled on it in indelible ink.
- 15.5 The Manufacturer shall provide instructions regarding handling and storage precautions to be taken at site.

**16) GUARANTEE**

The Manufacturer of insulators shall guarantee overall satisfactory performance of the insulators. The manufacturerer shall furnish in the form attached (Schedule 'A') all the guaranteed technical particulars.

**SCHEDULE – A1**

**GUARANTEED TECHNICAL PARTICULARS.**

**COMPOSITE INSULATOR UNIT**

**11KV(45KN) / 11KV(70KN),**

**(to be filled separately for each type mentioned above)**

<b>Sr.No</b>	<b>Parameter Name</b>	<b>Parameter type</b>	
1.	Type of insulator	Text	
2.	Standard according to which the insulators manufactured and tested	Text	
3.	Name of material used in manufacture of the insulator with class/grade	Text	
3.1	Material of core (FRP rod) i) E-glass or ECR-glass ii) Boron content		
3.2	Material of housing & weather sheds (Silicon content by weight)	Text	
3.3	Material of end fittings	Text	
3.4	Sealing compound for end fitting	Text	
4.0	Colour	Text	
5.	<b>Electrical characteristics</b>		
5.1.	Nominal system voltage	KV (rms)	Numeric
5.2	Highest system voltage	KV (rms)	Numeric
5.3	Dry Power frequency withstand voltage	KV (rms)	Numeric
5.4	Wet Power frequency withstand voltage	KV (rms)	Numeric
5.5	Dry flashover voltage	KV (rms)	Numeric
5.6	Wet flash over voltage	KV (rms)	Numeric
5.7	Dry lighting impulse withstand voltage a) Positive b) Negative	KV (peak) KV (peak)	Numeric
5.8	Dry lighting impulse flashover voltage a) Positive b) Negative	KV (peak) KV (peak)	Numeric
5.9	RIV at 1 MHz when energized at 10 kV/ 30 kV (rms) under dry condition	Micro volts	Numeric
6.0	Creepage distance (Min.) (320mm)	(mm)	Numeric
6.1	Center to center distance between tongue & clevis) (300mm)	(mm)	Numeric
6.2	Shed diameter (100mm)	(mm)	Numeric
7.0	Mechanical characteristics: Minimum failing load	KN	Numeric
8.0	<b>Dimensions of insulator</b>		
8.1	Weight	Kg	Numeric

<b>Sr.No</b>	<b>Parameter Name</b>	<b>Parameter type</b>
8.2	Dia. of FRP rod: mm	Numeric
8.3	Length of FRP rod mm	Numeric
8.4	Dia. of weather sheds (100mm) mm	Numeric
8.5	Thickness of housing mm	Numeric
8.6	Dry arc distance mm	Numeric
8.7	Dimensioned drawings of insulator (including weight with tolerances in weight) enclosed.	Boolean
9.0.	Method of fixing of sheds to housing (Specify): Single mould or Modular construction (Injection molding / compression molding)	Text
10.0	No of weather sheds	Text
11.0	<b>Type of sheds</b>	
11.1	Aerodynamic	Text
11.2	With underribs	Text
12.	<b>Packing details</b>	
12.1	Type of packing	Text
12.2	No. of insulators in each pack	Text
12.3	Gross weight of package	Text
13.0	Design Test Report, Type Test Report of insulator enclosed.	Boolean
14.0	Any other particulars which the Manufacturer may like to give	File

**SCHEDULE – A2**

**GUARANTEED TECHNICAL PARTICULARS.**

**COMPOSITE INSULATOR UNIT**

**22KV (70KN)**

<b>Sr.No</b>	<b>Parameter Name</b>	<b>Parameter type</b>
1.	Type of insulator	Text
2.	Standard according to which the insulators manufactured and tested	Text
3.	Name of material used in manufacture of the insulator with class/grade	
3.1	Material of core (FRP rod) i) E-glass or ECR-glass ii) Boron content	Text
3.2	Material of housing & weather sheds (silicon content by weight )	Text
3.3	Material of end fittings	Text
3.4	Sealing compound for end fitting	Text
4.0	Colour	Text
5.	<b>Electrical characteristics</b>	
5.1.	Nominal system voltage	KV (rms) Numeric
5.2	Highest system voltage	KV (rms) Numeric
5.3	Dry Power frequency withstand voltage	KV (rms) Numeric
5.4	Wet Power frequency withstand voltage	KV (rms) Numeric
5.5	Dry flashover voltage	KV (rms) Numeric
5.6	Wet flash over voltage	KV (rms) Numeric
5.7	Dry lighting impulse withstand voltage a) Positive b) Negative	KV (peak) KV (peak) Numeric
5.8	Dry lighting impulse flashover voltage a) Positive b) Negative	KV (peak) KV (peak) Numeric
5.9	RIV at 1 MHz when energized at 10 kV/ 30 kV (rms) under dry condition	Micro volts Numeric
6.0	Creepage distance (Min.)	mm Numeric
6.1	Center to center distance between tongue & clevis (mm)	Numeric
6.2	Shed diameter	(mm) Numeric
7.0	Mechanical characteristics: Minimum failing load	KN Numeric
8.0	<b>Dimensions of insulator</b>	
8.1	Weight	Kg Numeric

Sr.No	Parameter Name	Parameter type
8.2	Dia. of FRP rod: mm	Numeric
8.3	Length of FRP rod mm	Numeric
8.4	Dia. of weather sheds mm	Numeric
8.5	Thickness of housing mm	Numeric
8.6	Dry arc distance mm	Numeric
8.7	Dimensioned drawings of insulator (including weight with tolerances in weight) enclosed.	Boolean
9.0.	Method of fixing of sheds to housing (Specify): Single mould or Modular construction (Injection molding / compression molding)	Text
10.0	No of weather sheds	Text
11.0	<b>Type of sheds</b>	
11.1	Aerodynamic	Text
11.2	With underribs	Text
12.	<b>Packing details</b>	
12.1	Type of packing	Text
12.2	No. of insulators in each pack	Text
12.3	Gross weight of package	Text
13.0	Design Test Report, Type Test Report of insulator enclosed.	Boolean
14.0	Any other particulars which the Manufacturer may like to give	File

**SCHEDULE – A3**

**GUARANTEED TECHNICAL PARTICULARS.**

**COMPOSITE INSULATOR UNIT**

**33KV (70KN)**

<b>Sr.No</b>	<b>Parameter Name</b>	<b>Parameter type</b>
1.	Type of insulator	Text
2.	Standard according to which the insulators manufactured and tested	Text
3.	Name of material used in manufacture of the insulator with class/grade	
3.1	Material of core (FRP rod ) i) E-glass or ECR-glass ii) Boron content	Text
3.2	Material of housing & weather sheds (silicon content by weight )	Text
3.3	Material of end fittings	Text
3.4	Sealing compound for end fitting	Text
4.0	Colour	Text
5.	<b>Electrical characteristics</b>	
5.1.	Nominal system voltage KV (rms)	Numeric
5.2	Highest system voltage KV (rms)	Numeric
5.3	Dry Power frequency withstand voltage KV (rms)	Numeric
5.4	Wet Power frequency withstand voltage KV (rms)	Numeric
5.5	Dry flashover voltage KV (rms)	Numeric
5.6	Wet flash over voltage KV (rms)	Numeric
5.7	Dry lighting impulse withstand voltage a) Positive KV (peak) b) Negative KV (peak)	Numeric
5.8	Dry lighting impulse flashover voltage a) Positive KV (peak) b) Negative KV (peak)	Numeric
5.9	RIV at 1 MHz when energized at 10 kV/ 30 kV (rms) under dry condition Micro volts	Numeric
6.0	Creepage distance (Min.) mm	Numeric
6.1	Center to center distance between tongue & clevis (mm)	Numeric
6.2	Shed diameter (mm)	Numeric
7.0	Mechanical characteristics: Minimum failing load KN	Numeric
8.0	<b>Dimensions of insulator</b>	
8.1	Weight Kg	Numeric

Sr.No	Parameter Name	Parameter type
8.2	Dia. of FRP rod: mm	Numeric
8.3	Length of FRP rod mm	Numeric
8.4	Dia. of weather sheds mm	Numeric
8.5	Thickness of housing mm	Numeric
8.6	Dry arc distance mm	Numeric
8.7	Dimensioned drawings of insulator (including weight with tolerances in weight) enclosed.	Boolean
9.0.	Method of fixing of sheds to housing (Specify): Single mould or Modular construction (Injection molding / compression molding)	Text
10.0	No of weather sheds	Text
11.0	<b>Type of sheds</b>	
11.1	Aerodynamic	Text
11.2	With underribs	Text
12.	<b>Packing details</b>	
12.1	Type of packing	Text
12.2	No. of insulators in each pack	Text
12.3	Gross weight of package	Text
13.0	Design Test Report, Type Test Report of insulator enclosed.	Boolean
14.0	Any other particulars which the Manufacturer may like to give	File



**ANNEXURE 'A'**

**STANDARDS TO BE ADOPTED FOR COMPOSITE INSULATORS**

<b>Sr.</b>	<b>Indian Standard</b>	<b>Title</b>	<b>International Standard</b>
1	-	Definition, test methods and acceptance criteria for composite insulators for A.C. overhead lines above 1000V	IEC: 61109
2	IS: 731	Porcelain insulators for overhead power lines with a nominal voltage greater than 1000V	IEC: 60383
3	IS: 2071	Methods of High Voltage Testing	IEC: 60060-1
4	IS: 2486	Specification for Insulator fittings for Overhead power Lines with a nominal voltage greater than 1000V General Requirements and Tests Dimensional Requirements Locking Devices	IEC: 60120 IEC: 60372
5.	-	Thermal Mechanical Performance test and mechanical performance test on string insulator units	IEC: 60575
6.	IS: 13134	Guide for the selection of insulators in respect of polluted condition	IEC: 60815
7.	-	Characteristics of string insulator units of the long rod type	IEC: 60433
8.	-	Hydrophobicity Classification Guide	STRI guide 1.92/1
9.	-	Radio interference characteristics of overhead power lines and high-voltage equipment.	CISPR: 18-2 Part 2
10.	IS: 8263	Methods of RI Test of HV insulators	IEC: 60437
11.		Standard for Insulators- Composite-Distribution Dead-end Type	ANSI C29.13-2000
12.	IS: 4759	Hot dip zinc coatings on structural steel & other allied products	ISO: 1459 ISO: 1461
13.	IS: 2629	Recommended Practice for Hot, Dip Galvanization for iron and steel	ISO: 1461 (E)
14.	IS: 6745	Determination of Weight of Zinc Coating on Zinc coated iron and steel articles	ISO: 1460
15.	IS: 3203	Methods of testing of local thickness of electroplated coatings	ISO: 2173
16.	IS: 2633	Testing of Uniformity of Coating of zinc coated articles	
17.	-	Standard specification for glass fiber strands	ASTM D 578-05
18.	-	Standard test method for compositional analysis by Thermogravimetry	ASTM E 1131-03
19.	IS:4699	Specification for refined secondary Zinc	

**Annexure-B****Tests on Insulator units****1 RIV Test (Dry)**

The insulator string along with complete hardware fittings shall have a radio interference voltage level below 100 micro volts at one MHz when subjected to 50 Hz AC voltage of 10kV & 30 kV for 11 kV & 33 kV class insulators respectively under dry condition. The test procedure shall be in accordance with IS:8263 /IEC:437/CISPR 18-2.

**2 Brittle Fracture Resistance Test**

Brittle fracture test shall be carried out on naked rod along with end fitting by applying "1N HNO<sub>3</sub> acid" (63 g conc. HNO<sub>3</sub> added to 937 g water) to the rod. The rod should be held 80% of SML for the duration of the test. The rod should not fail within the 96-hour test duration. Test arrangement should ensure continuous wetting of the rod with Nitric acid.

**3 Recovery of Hydrophobicity & Corona test**

The test shall be carried out on 4mm thick samples of 5cm X 7cm.

- i. The surface of selected samples shall be cleaned with isopropyl alcohol. Allow the surface to dry and spray with water. Record the Hydrophobicity classification in line with STRI guide for Hydrophobicity classification. Dry the sample surface.
- ii. The sample shall be subjected to mechanical stress by bending the sample over a ground electrode. Corona is continuously generated by applying 12 kV to a needle like electrode placed 1mm above the sample surface. The test shall be done for 100 hrs.
- iii. Immediately after the corona treatment, spray the surface with water and record the HC classification. Dry the surface and repeat the corona treatment as at clause 2 above. Note HC classification. Repeat the cycle for 1000 hrs. or until an HC of 6 or 7 is obtained. Dry the sample surface.
- iv. Allow the sample to recover and repeat hydrophobicity measurement at several time intervals. Silicone rubber should recover to HC 1 – HC 2 within 24 to 48 hours, depending on the material and the intensity of the corona treatment.

**4 Chemical composition test for Silicon content**

The content of silicon in the composite polymer shall be evaluated by EDX (Energy Dispersion X- ray) Analysis or Thermo-gravimetric analysis. The test may be carried out at CPRI or any other NABL accredited laboratory.

**25 Guy Strain Insulators**

**1. SCOPE**

This Specification covers porcelain guy strain insulators for use in rural electrification system.

**2. APPLICABLE STANDARDS**

Unless otherwise modified in this specification, the insulators shall comply with IS: 5300-1969 or the latest version thereof.

**3. GENERAL REQUIREMENTS**

- 3.1** The porcelain insulator shall be sound, free from defects, thoroughly vitrified and smoothly glazed.
- 3.2** The design of the insulator shall be such that the stresses due to expansion and contraction in any part of the insulator shall not lead to its deterioration.
- 3.3** The glaze, unless otherwise specified, shall be brown in colour. The glaze shall cover the entire porcelain surface parts except those areas that serve as supports during firing.

**4. TYPE OF INSULATORS**

- 4.1** The standard guy strain insulators shall be of designations 'A' and 'C' as per IS:5300.
- 4.2** The recommended type of guy strain insulators for use on guy wires of overhead lines of different voltage levels are as follows :

Power Line Voltage	Designation of Insulators
415/240V	A
11000V	C
33000V	C (2 Insulators to be used in series)

**5. DIMENSIONS**

The dimensions of guy strain insulators shall be in accordance with Figs. 1 and 2.

**6. BASIC INSULATION LEVELS**

The test voltage of the insulators shall be as under :

Designation of Insulator	Dry one minute power Frequency withstand voltageKV (rms)	Wet one minute power Frequency withstand voltage KV (rms)
A	18	8
C	27	13

**7. MECHANICAL STRENGTH**

The insulators shall be suitable for the minimum failing loads specified as under:

Designation of Insulator	Minimum failing load (KN)
A	44
	88

**8. TESTS**

The insulators shall comply with the following routine, type and acceptance tests as per IS:5300.

**8.1 Routine Test**

Visual examination

**8.2 Type Tests**

- a) Visual examination
- b) Verification of dimensions
- c) Temperature cycle test
- d) Dry one-minute power-frequency voltage withstand test
- e) Wet one-minute power frequency voltage withstand test
- f) Mechanical strength test
- g) Porosity test

**8.3 Acceptance Tests:** (to be conducted in the following order)

- a) Verification of dimensions
- b) Temperature cycle test
- c) Mechanical strength test
- d) Porosity test

**9. MARKING**

**9.1 Each insulator shall be legibly and indelibly marked to show the following :**

- a) Name or trade mark of the manufacturer
- b) Year of manufacture
- c) ISI certification mark, if any.

**9.2 Marking on porcelain shall be applied before firing.**

**10. PACKING**

All insulators shall be packed in wooden crates suitable for easy but rough handling and acceptable for rail transport. Wooden separators shall be fixed between the insulators to keep individual insulators in position without movement within the crate.

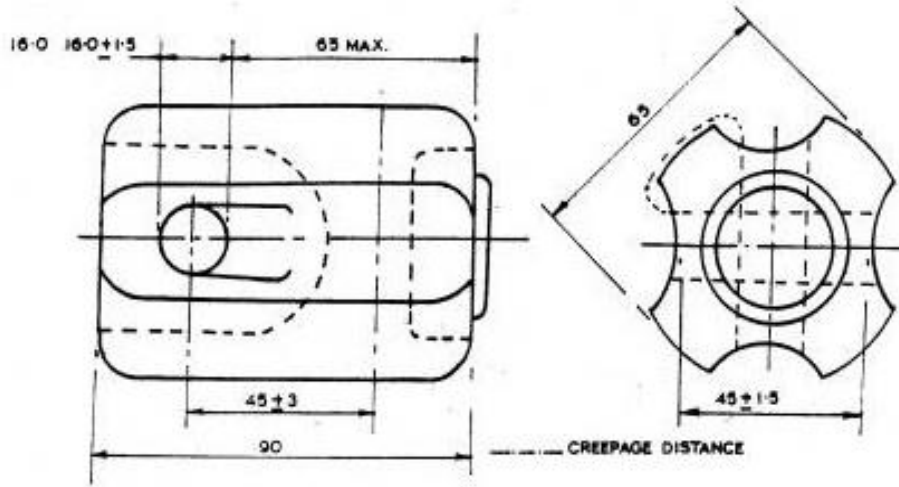

चित्र-१. तान रस्सी विकृतिसह विद्युतरोधक - संज्ञा ए.  
FIG. 1. GUY STRAIN INSULATOR (DESIGNATION- A)

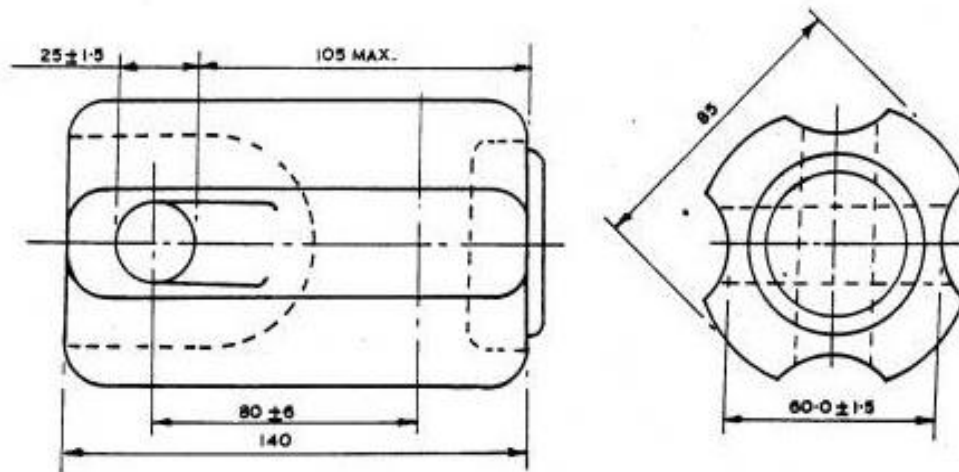

चित्र-२ तान रस्सी विकृतिसह विद्युतरोधक - संज्ञा सी.  
FIG. 2. GUY STRAIN INSULATOR (DESIGNATION - C )

ALL DIMENSIONS ARE IN mm

**26 Helically Formed Fittings for 11 kV and LT Lines**

**1. SCOPE**

This Standard specifies the requirements and tests for helically formed fittings for use on 11 KV and LT overhead lines.

The following types of fittings are covered:-

- a) Conductor dead end fittings
- b) Distribution ties, side ties and double ties
- c) Conductor splices
- d) Guy grip dead-ends
- e) Tap connectors
- f) Service grip dead-ends
- g) Lashing rods

**2. GENERAL REQUIREMENTS**

**2.1** Aluminium alloy, aluminium-clad steel and galvanised steel wires having required mechanical strength, corrosion resistance and formability, depending on the type of application shall be employed in the manufacture of the fittings. The material of the formed fittings shall be compatible with the conductors with which it is used.

**2.2** In case of formed wires, no joints shall be permitted except those in the base rod or wire before final drawing.

**2.3** Each formed set shall be marked with indelible and distinct colour to indicate starting/cross-over point of application to facilitate its application on the conductor.

**2.4** The ends of the individual wires of the formed fittings shall be suitably debarred to provide a smooth finish so as to avoid any damage to the conductor due to sharp edges.

**2.5** Suitable grit shall be applied to the gripping section of the formed fitting (except lashing rods) in order to enhance its gripping strength.

**3. PROPERTIES OF WIRES**

**3.1** Materials of the wires used in the manufacture of the fittings covered by this specification shall have the mechanical and electrical properties as specified in Tables 1,2 and 3. Materials used for chloroprene pad shall have the properties specified in Table 4.

**Table 1**

**Aluminium Alloy Wires**

Test	Requirements
1. Visual	a) No scratches
	b) No peeling off

	c) No speed crack
	d) No cut mark
2. Dimensions after forming	a) Diameter Tolerance (+) .000 mm (-) .025 mm
	b) Flattening (+) .000 mm (-) .076 mm
3. Tensile strength of formed wires	35 Kg/mm <sup>2</sup>
4. Elongation of finished wire	Min. 2% in a gauge length of 50 mm
5. Conductivity of finished wire	Min. 39% as per IACS
6. <u>Wrap test</u> Wire diameter mm	Min. number of twists on a mandrel of its own dia without fracture at a rate of 15 turn per minute
Upto 3.07	18
From 3.08 to 3.45	16
From 3.46 to 3.71	14
From 3.72 to 4.24	12
From 4.25 and above	10

**Table 2**  
**Aluminium Clad Steel Wires**

S.No.	Test	Requirements
1.	Visual	Free from splints, scale, inequalities, flaws and other irregularities :
2.	Dimensional	Roundness to (±) 0.013mm
3.	Tensile strength	As per table 2a below
4.	Weight of coating	As per table 2b below
5.	Wrap test (on a mandrel 2 times the dia of the sample and at the rate of 15 turns/minute)	After close helix, the sample should not fracture

6.	Adherence of coating (in a close helix not exceeding 15 turns/minute) around a cylindrical mandrel having a diameter prescribed in table 2c.	No cracking or flaking to such an extent that the aluminium coating can be removed by rabbing with the bare fingers
----	--	---

**Table 2a**

<b>Wire diameter (mm)</b>	<b>Ultimate tensile strength minimum) MPa</b>	<b>Ultimate elongation (Min.) percent in 254 mm</b>
1.270 to 2.283 including	1280	3.0
2.286 to 3.045 including	1240	3.5
3.048 to 3.515 including	1210	4.0
3.518 to 3.782 including	1170	4.0
3.785 to 4.826 including	1140	4.0

**Table 2b**

<b>Wire diameter (mm)</b>	<b>Min. weight of aluminium coating on uncoated wire surface (gms/m<sup>2</sup>)</b>
1.270 to 1.521 including	70
1.524 to 1.902 including	76
1.905 to 2.283 including	79
2.286 to 2.639 including	85
2.642 to 3.045 including	92
3.048 to 3.553 including	98



3.556 to 4.569 including	104
4.572 to 4.826 including	116

**Table 2c**

<b>Wire diameter</b>	<b>Min. ratio of mandrel diameter to wire diameter</b>
1.270 to 2.283 including	3
2.286 to 3.553 including	4
3.556 to 4.826 including	5

**Table 3**  
**Zinc coated steel wire**

	<b>Test</b>	<b>Requirements</b>
1.	Visual	Free from splints, scale, inequalities and other irregularities :
2.	Dimensional	Roundness to ( $\pm$ ) 0.013mm
3.	Tensile strength of finished wire	As per table 3a below
4.	Weight of zinc coating	As per table 3b below
5.	Wrap test (on a mandrel 2 times the dia of the sample and at the rate of 15 turns/minute)	After close helix of minimum 8 turns, the sample should not fracture.
6.	Adherence of coating (in a close helix not exceeding 15 turns/minute) around a cylindrical mandrel having a diameter prescribed in table 3c.	No cracking or flaking to such an extent that zinc coating can be removed by rabbing with the bare fingers

**Table 3 a**

<b>Wire diameter mm</b>	<b>Ultimate tensile strength (Minimum) MPa</b>	<b>Elongation in 200 mm gauge length minimum (%) mm</b>
1.270 to 2.283 including	1450	3.0
2.286 to 3.045 including	1410	3.5
3.048 to 3.053 including	1410	4.0
3.556 to 4.022 including	1380	4.0

**Table 3b**

<b>Wire diameter (mm)</b>	<b>Minimum weight of zinc coating on uncoated wire surface (gms/m<sup>2</sup>)</b>
1.270 to 1.521 including	183
1.524 to 1.902 including	198
1.905 to 2.283 including	214
2.286 to 2.639 including	229
2.642 to 3.045 including	244
3.048 to 3.553 including	259
3.556 to 4.69 including	274
4.572 to 4.822 including	305

**Table 3c**

<b>Wire diameter (mm)</b>	<b>Ratio of mandrel diameter to wire diameter</b>
1.270 to 2.283 including	3
2.286 to 3.553 including	4
3.556 to 4.822 including	5

**Table 4**  
**Properties for Chloroprene pad**  
**Chloroprene cushion shall have following properties :**

<b>1a)</b>	<b>Tensile Strength</b>	<b>Minimum 100Kg/cm<sup>2</sup></b>
b)	Tensile strenght (after ageing)	Loss of maximum 25% of the test value obtained in 1(a)
2a)	Elongation	250% minimum
b)	Elongation (after ageing)	Loss of maximum 25% of the test value obtained in 2(a)
3a)	Shore hardness 'A'	65 (±)5
b)	Shore hardness (after ageing)	(±)15% of test values obtained in 3(a)

**Note :** Ageing should be carried out for 70 hours at 100°C.

#### **4. REQUIREMENTS OF FORMED FITTINGS FOR VARIOUS APPLICATIONS**

##### **4.1 Conductor Dead-end fittings**

**4.1.1** Formed conductor dead-end fitting for 11 KV lines consists of the following parts for use with disc insulators of clevis and tongue type:

a) Cross arms strap for attaching the fittings to the pole on one side and the disc insulator on the other. These fittings shall conform to the REC Specifications of 11 KV Porcelain Insulators and Fitting.

b) Aluminium alloy die cast thimble clevis for attaching the fitting to the tongue of disc insulator on one end and for accomodating loop of the helically formed fitting at the other end in its smooth internal contour. The thimble clevis is attached to the insulator through a steel cotter pin used with a non-ferrous split pin of brass or stainless steel. The thimble clevis shall have clevis dimensions as per IS : 2486 (Part II) - 1989 and shall have the minimum failing load strength of 3000 kg.

c) Helically formed fitting acting as the dead-end grip.

**4.1.2** The die-cast aluminium alloy thimble clevis shall be manufactured with alloy A6 Designation of IS : 617 - 1975.

**4.1.3** Nuts and bolts used shall be of galvanised steel conforming to IS : 1364 - 1967 and cotter pins conforming to IS : 2004 -1978. Spring washers used shall be electro-galvanised.

**4.1.4** The fitting for LT lines shall comprise of the helically formed fitting to suit the LT shackle insulator as per REC Specification of Porcelain Insulators and Insulator Fittings For 415/240V Overhead Power Lines

**4.1.5** The fittings shall be made to suit the following conductor sizes for 11 KV/LT Lines conforming to REC Specification 1/1971(R-1993) and each fitting shall have a clear identification mark on PVC/metallic/plastic tag, indicating size of the conductor and voltage. The following colour code shall be used for the tag as also for the starting/cross-over marks for quick identification:

20 mm <sup>2</sup> ACSR(Squirrel)	Blue
30 mm <sup>2</sup> ACSR(Weasel)	Red
50 mm <sup>2</sup> ACSR (Rabbit)	Yellow
50 mm <sup>2</sup> ACSR (Rabbit)	Brown
50 mm <sup>2</sup> AAC (Ant)	Grey

**4.2** Distribution ties side ties and double ties

**4.2.1** Helically formed ties are used to hold the conductor to pin insulators or shackle insulators.]

**4.2.2** Chloroprene pad shall be provided with the formed ties for use on 11 KV lines to avoid abrasion of the conductor

**4.2.3** The conductor sizes and voltage class shall be clearly marked on each fitting and the fittings shall also be identified by color code as per clause 4.1.5.

**4.2.4** To ensure proper fitting of 11 KV pin insulator ties, the purchaser shall furnish full-dimensions of the insulator top particularly the crown diameter, neck diameter etc. See REC specification 11KV porcelain insulators and fittings.

**4.3 Conductor Splices**

**4.3.1** Conductor splices for ACSR conductors shall consist of (i) galvanised steel formed splice for steel core (ii) aluminium alloy formed filler rod (iii) aluminium alloy formed splice for the aluminium strands of the conductor. For AAC conductor, splice is formed with aluminium alloy only.

**4.3.2** Repair Splice: Repair splices are non-tension splices and are used where some of the outer strands of the conductor are damaged.

**4.4 Guy Grip Dead-End**

**4.4.1** Guy grip dead ends have one leg shorter than the other and are suitable for gripping the guy wire. These grips are applied on one side into the thimble eye of the stay rod and on the other side to the guy wire. These can also be used directly with guy insulators.

**4.4.2** The fittings shall be made of two sizes to suit stay wires of 7/3.15mm(7/10SWG) and 7/2.5 mm(7/12SWG) having UTS values 3625 kg and 2300 kg respectively.

**4.4.3** The fittings shall be clearly identified on a PVC/mettalic/plastic tag for the size of stay wire with which these are to be used and, in addition, the following colour codes for the tag as well as the corss-over marks shall be adopted for proper identification:

- Guy grip for 7/3.15 mm stay wire - Green
- Guy grip for 7/2.5 mm stay wire - Black

**4.4.4** The guy grip shall be supplied complete with thimble to suit the fitting. Thimble shall be made of hot-dipped galvanized steel.

**Note:** The guy grips to be used with guy insulators shall take into account the standard sizes of insulators as per REC specification and the type and size of the guy insulator shall be clearly specified by the purchaser.

**4.5** Tap Connectors: Tap connectors consist of helically formed aluminium alloy wires for non-tension tapping of conductors and cables from the main line. The sizes of conductors/cables for which these tap connectors are to be used have to be clearly specified by the purchaser.

**4.6** Service Grip Dead End: Service grip dead-ends are used with metallic knob to hold one or more service bearer wires.

**4.7** Lashing Rods: Lashing rods are helically formed wires to secure the bearer wire to the service cable. The number of lashing rods will depend on the length of service.

**5. DIMENSIONAL REQUIREMENTS OF THE FINISHED FORMED FITTINGS**

**5.1** The lay of the helix shall be right hand.

**5.2** The diameter and number of formed rods used per set of fittings to be used on various sizes of conductors shall be as per the approved drawings.

**5.3** Tolerances of formed fittings: The various requirements of the helically formed fitting shall be within the following tolerances:

	<b>Item</b>	<b>Tolerances</b>
	Pitch length	+ 0.6 mm (-)0.12 mm
	Internal diameter	+ 1% (-) 3%
	Length of individual rod	(±) 1%
	Difference in length	(±) 1% between the longest and the shortest rod in an individual set

**6. TESTS**

**6.1 Type Tests:** The following tests shall constitute the type tests on the finished fittings:

	<b>Applicable to</b>
Visual examination	All fittings
Verification of dimension	All fittings

Tensile strength test	All fittings
Electrical resistance test	All aluminium alloy fittings
Wrapping test	All fittings
Slip strength test	Conductor dead-end, guy grip and splices
Resilience test	Conductor dead-end, guy grip and conductor splices
Unbalanced holding Strength Test	Ties only
Fatigue test	Conductor dead-end, ties and splices
Galvanising test	Hardwares and fittings using GI wire
Pull-off strength test	Ties only
Electrical & Mechanical Test	Tap Connectors

**Acceptance Test:** The following shall constitute the acceptance test:

1. Visual examination
2. Verification of dimension
3. Tensile Strength test
4. Electrical resistance test
5. Wrapping test
6. Slip Strength test
7. Resilience test
8. Unbalanced load
9. Galvanisation test
10. Pull-off strength
11. Electrical & Mechanical tests on tap connectors
12. The tests for other requirements as per Tables 1,2,3 & 4 on the individual wires used in making the helically formed fittings and chloroprene pad (where used).

**6.2 Routine Tests:** The following shall constitute the routine tests:

- a) Visual examination
- b) Verification of dimensions

## 7. TEST PROCEDURE

**7.1** Visual Examination: All fittings and individual wires shall be checked visually for good workmanship, smooth finish and other requirements indicated in Table 1, 2 and 3.

**7.2** Verification of dimensions: The dimensions shall be checked as specified in the tables 1, 2, 3 and clause 5.

**7.3** Tensile Strength Test:

**7.3.1** Individual wire of the helically formed wires shall be straightened by light hammering and tested for tensile strength and elongation in accordance within the IS:398(Part II)-1976. The tensile strength and the elongation of the formed wires shall not be less than the values specified in tables 1, 2 and 3.

**7.3.2** For thimbles and hardwares other than formed fittings:

The dead-end clevis thimble and straps shall be tested for tensile strength in accordance with the requirements of mechanical failing load as per IS:2486(Part I)-1993.

**7.4** Electrical Resistance Test: This test shall be done on straightened aluminium alloy formed wires only. The conductivity of the wires should not be less than 39% IACS.

**7.5** Wrapping Test: The individual wires of the formed fittings shall be tested as specified in tables 1, 2 and 3. The wires should not break or show fracture when tested as above.

**7.6** Slip Strength Test: For the conductor dead-end and guy grip dead-end, the test shall be made in accordance with IS:2486(Part I)-1993 and the value of slip/breaking strength shall not be less than 85% of the breaking strength of the conductor for conductor dead-end fitting and 100% for guy wires dead end fittings. In case of tension splices, the test shall be carried out as per IS:2121. No slippage or damage to the fitting shall occur at a value less than 100% of breaking load of the conductor. This test should be repeated after the resilience test.

**7.7** Resilience Test: A set of helically formed fitting is wrapped and un-wrapped on a piece of conductor 3 times successively. The helical fitting should not lose its resilience even after three applications and should be able to pass the slip strength test requirements mentioned in 7.6 thereafter.

**7.8** Unbalanced Holding test: Unbalanced holding strength is the ability of the formed ties to maintain a constant and uniform grip on the conductor when intermittent and repeated unbalanced loads impose a tension imbalance in the span. These imbalances occur due to wind induced motion, impacts, ice conditions and more so when the conductor is broken.

The test is intended to simulate the broken wire condition. A span of minimum 20 meters tensioned for 40% of UTS of the conductor shall be erected in the laboratory and a pin insulator alongwith the insulator tie under test shall be applied in the middle of span. The conductor used for this purpose shall be of the specific size with which the insulator tie is to be used. The test set up shall be such that it should be possible to apply a pull on one of the two dead ends of the conductor. For the purpose of this test, a steel replica of the insulator will be used. During the test, tension on one side of the pin insulator shall be suddenly released and effect observed. No slippage or damage to the fitting shall occur. After releasing tension from the other end, the fitting should retain the original form. This test will not only check the holding strength of the fitting but will also prove the resilience of the fitting in the event of broken wire.

The test shall be repeated. After releasing the conductor tension on one side, pulling force shall be slowly applied on the other dead-end to pull the conductor till slippage/damage occurs. This force shall not be less than 320 kg.

- 7.9 Fatigue Test:** The fittings should be subjected to fatigue test alongwith the conductor by imparting 10 million cycles of peak to peak amplitude at a frequency above 30 cycles for minimum span length of 20 meters, at 40% of UTS of conductor. The amplitude of the vibrations at the antinodal points should be atleast 50% of the diameter of the conductor. The test should be carried out for 10 million cycles as continuously as possible after which the conductor fitting and insulator should be examined. There should be no damage to the conductor or the insulator where the fitting is attached. The fitting should also be able to withstand the test without any damage.
- 7.10 Galvanising Test:** Galvanising test should be carried out in accordance with IS:4826-1979 for uniformity and IS:6745-1972 for weight of zinc coating and the fittings will meet the requirements of Table 3.
- 7.11 Pull-Off Strength Test:** This test is intended to simulate the conductor pull-off conditions created by various factors including elevation difference of the supporting structures on the two sides of the tie. A span of minimum 20 metres tensioned for 40% of UTS of the conductor shall be erected in the laboratory with a conductor of the specified size with which the fitting is intended to be used. A steel replica of pin insulator alongwith the insulator tie under test shall be applied in the middle of span so that a suitable pull-off force can be applied on the pin by means of a machine. The pull-off strength of the tie shall not be less than 200 Kg. for all the three sizes of ACSR.
- 7.12 Electrical & Mechanical Test on Tap Connectors:** The tap Connector shall conform to all the electrical and mechanical properties as per IS:5561.

## **8. PACKING AND MARKING**

- 8.1** All helically formed items covered under this specification shall be carefully handled to prevent distortion and damage. These items shall be packed and stored in suitable cartons.
- 8.2** Different colour codes shall be adopted for different conductor sizes and catalogue number and range of outside diameter of the conductor shall be indicated on the packing.
- 8.3** Clevis thimbles and other hardwares for conductor dead-ends shall be packed in wooden crates with all necessary markings.
- 8.4** The packings of the fittings should carry the following informations.
- a) Purchaser's name
  - b) Manufacturer's name and trade mark
  - c) Size of conductor, line voltage (when required) and numbers
  - d) Batch number, date, month and year of manufacture
  - e) Any other marking agreed to between manufacturer and user.



REC  
CONSTRUCTION STANDARD  
C-3



DISTRIBUTION TIE

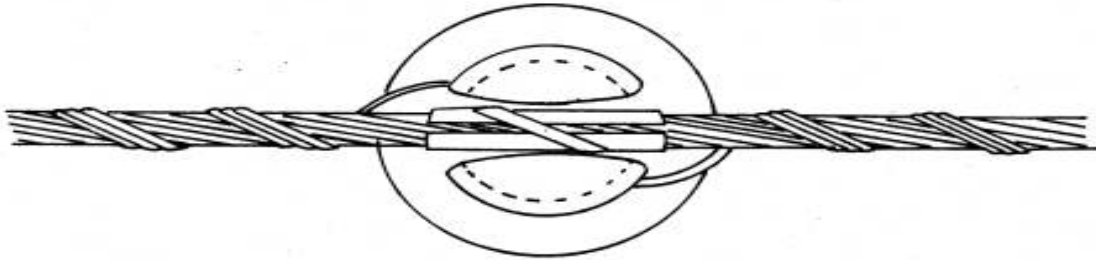

DISTRIBUTION TIE IN POSITION ON 11KV PIN INSULATOR

**NOTE**

FOR DETAILS OF HELICALLY FORMED FITTING REFER REC SPECIFICATION NO. 25/1983

११ के. वी. पिन इन्सुलेटर पर कन्डक्टर  
प्रस्थापित करना - स्ट्रेट-रन  
(सर्पिल आकार के फॉर्मड फिटिंग का प्रयोग करना)  
HOLDING OF CONDUCTOR ON  
11KV PIN INSULATOR - STRAIGHT RUN  
(USING HELICALLY FORMED FITTING)

SCALE :- N.T.S

JULY, 1984.

REC  
CONSTRUCTION STANDARD  
C-4

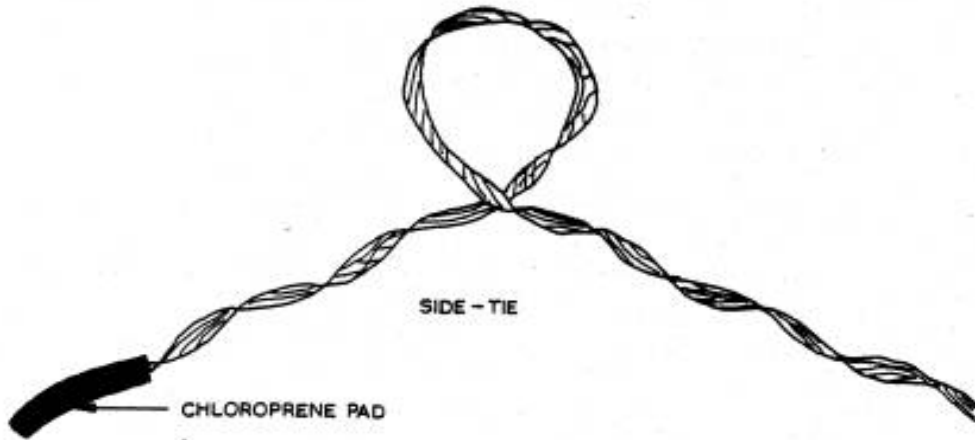

NOTE :- FOR DETAILS OF HELICALLY FORMED FITTINGS  
REFER REC SPECIFICATION NO. 25/1983.

११ के. वी. पिन इन्सुलेटर पर कन्डक्टर स्थापित करना - सही लोकेशन (सही पैसा आकार के हेलिकल फिटिंग का प्रयोग करना)	
HOLDING OF CONDUCTOR ON 11KV PIN INSULATOR - ANGLE LOCATION (USING HELICALLY FORMED FITTING)	
SCALE:-N.T.S	JULY, 1984

REC  
 CONSTRUCTION STANDARD  
 C-5



CONDUCTOR DEAD-END FITTING

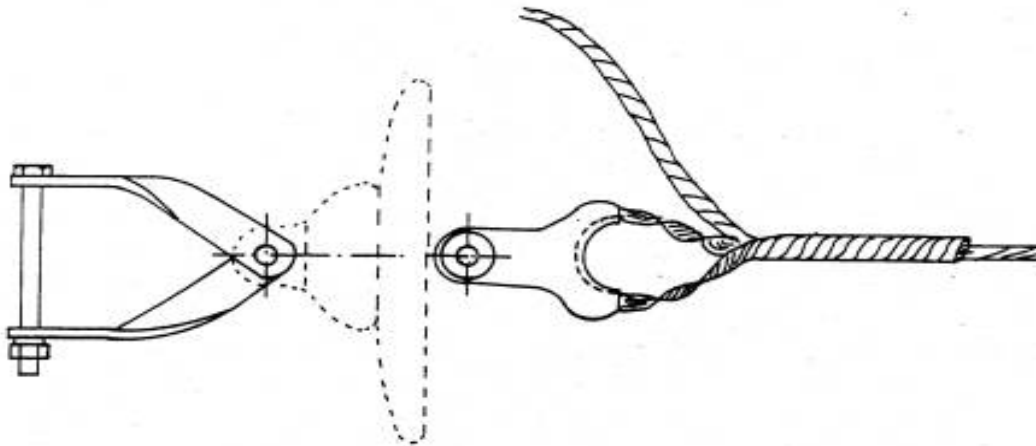

11KV CONDUCTOR DEAD-END FITTING IN POSITION

11 KV STRAIN INSULATOR HARDWARE CONSIST OF:

1. HELICALLY FORMED DEAD-END FITTING
2. CLEVES THIMBLE AND
3. CROSS-ARM STRAP WITH BOLT.

**NOTE:-**

FOR DETAILS OF HELICALLY FORMED FITTING REFER  
 REC SPECIFICATION NO. 25/1983

११ के. वी. कन्डक्टर अन्तिम धरे का किन्धस  
 (सर्पिल आकार के फॉर्मड फिटिंग का प्रयोग  
 करना)

11KV CONDUCTOR DEAD-END ARRANGEMENT  
 (USING HELICALLY FORMED FITTINGS)

SCALE :- N.T.S

JULY, 1984

REC  
CONSTRUCTION STANDARD  
E-31

USE OF LASHING RODS TO SECURE THE OVERHEAD BEARER WIRE AND  
THE PVC SERVICE CABLE



FIGURE-1

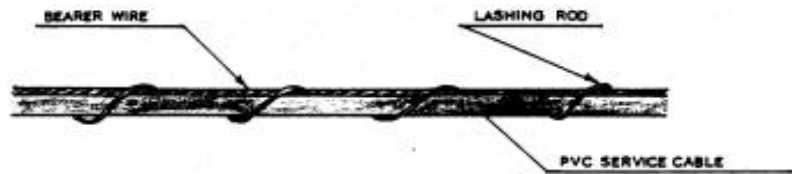

FIGURE-2

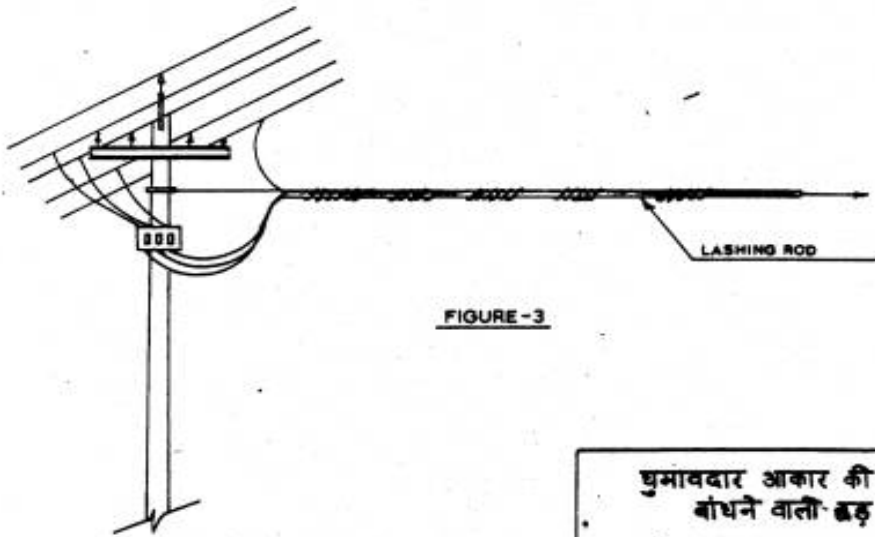

FIGURE-3

FIG-1 SHOWS THE LASHING ROD.  
FIG.2&3 SHOW THE LASHING RODS IN POSITION.

घुमावदार आकार की फिटिंग  
बांधने वाली छड़  
HELICALLY FORMED FITTINGS  
LASHING RODS  
SCALE:- N.T.S | JULY-1984

R E C  
 CONSTRUCTION STANDARD  
 E - 32

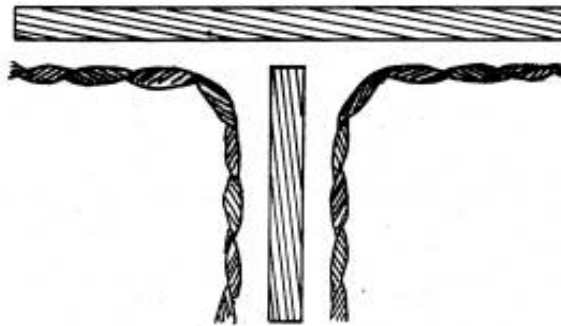

FIGURE - 1

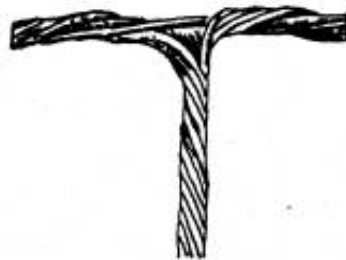

FIGURE - 2

NOTE:-

T-CONNECTORS CAN BE USED TO TAP SERVICE CONNECTIONS FROM THE LINE OR FOR TAPPING A BRANCH LINE FROM THE MAIN LINE.

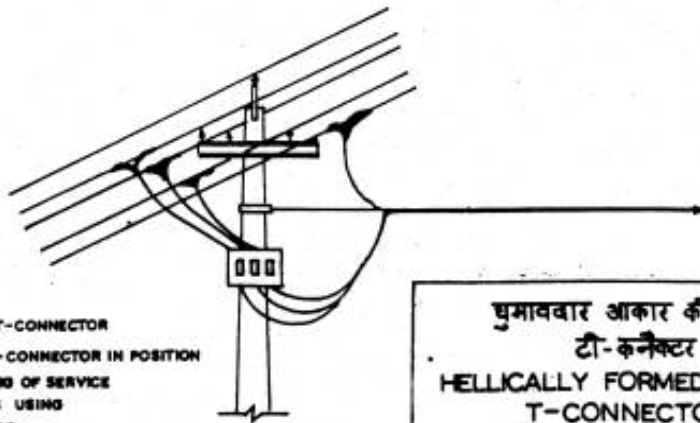

FIG.1 SHOWS THE T-CONNECTOR  
 FIG.2 SHOWS THE T-CONNECTOR IN POSITION  
 FIG.3 SHOWS TAPPING OF SERVICE CONNECTIONS USING T-CONNECTORS.

FIGURE - 3

घुमावदार आकार की फिटिंग टी-कनेक्टर HELICALLY FORMED FITTINGS T-CONNECTOR	
SCALE:- N.T.S	JULY - 1984

R E C  
 CONSTRUCTION STANDARD  
 E-33

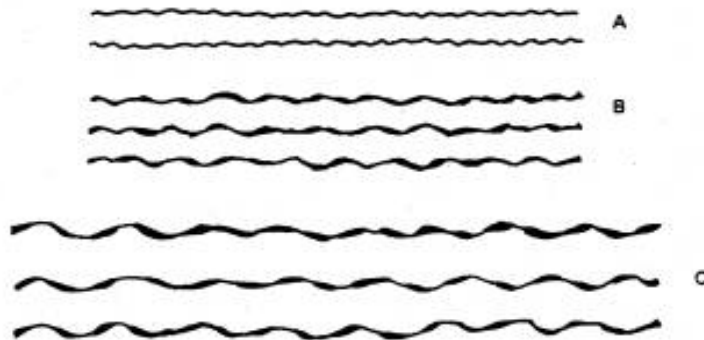

FIGURE-1

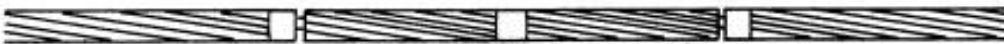

FIGURE-2

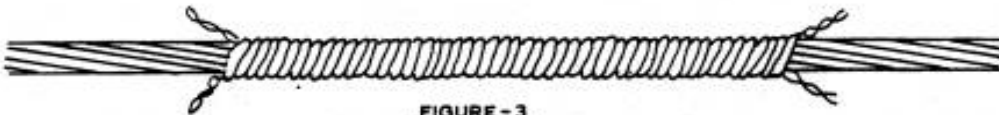

FIGURE-3

- A SHOWS THE CORE SPLICE
- B SHOWS THE FILLER RODS.
- C SHOWS THE OUTER SPLICE
- FIG. 1. SHOWS THE CORE SPLICE IN POSITION
- FIG. 2. SHOWS THE CORE SPLICE AND FILLER RODS IN POSITION
- FIG. 3. SHOWS THE COMPLETE JOINT AND THE OUTER SPLICE IN POSITION.

घुमावदार आकार की फिटिंग र.सी.एम.आर. के लिए स्पलाईस HELLICALLY FORMED FITTINGS SPLICE FOR ACSR JOINT	
SCALE :- N.T.S	

**27 Insulation Piercing Connectors, Anchor (Dead End) & Suspension Accessories & Other Accessories for Aerial Bunched Cables for Working Voltage upto and including 1100 Volts**

**1.0 SCOPE**

This specification covers the design, manufacture, assembly, testing and supply of Accessories for anchoring, suspending & making connections to Aerial Bunched Cables rated 1100 volts and insulated with cross-linked polyethylene.

**2.0 STANDARD**

The design, performance and test requirements shall confirm to this specification and the following standards. However in case of any conflict, the requirements of this specification shall prevail.

- NFC 33-020 Insulation Piercing Connectors
- NFC 33-209 LV Aerial Bunched Cables
- NFC 20-540 Environment Testing for Outdoor
- NFC 33-004 Electrical Ageing Test
- NFC 33-040 Suspension Equipments
- NFC 33-041 Anchoring Devices
- IS 14255 LV Aerial Bunched Cables

The Devices shall also be compatible with the cables of sizes & dimensions as defined in the Cable Specifications for the cables with which they are intended to be used.

**3.0 CLIMATIC CONDITIONS**

For the purpose of designing the climatic conditions as specified in annexure-1 shall be considered.

**4.0 CABLE DATA**

The standard sizes and characteristics of the phase and street lighting conductors, messenger wires shall be as specified in IS: 14255-1995.

The Accessories of LT XLPE Insulated Aerial Bunched Cables (ABC) with **insulatedbare** messenger cum neutral are specified below:

- a) The ABC accessories should be of proven design with minimum 2 years record of satisfactory operation with a major utility. Order copies and Performance Certificates should be enclosed with the offer.
- b) Since ABC accessories are to be used with **insulated bare** neutral-cum-messenger, their design should incorporate specific features to prevent damage to the insulation which meeting the required electrical, mechanical & thermal requirements.
- c) All mechanical, electrical & thermal ratings should meet or exceed 90% of the corresponding ratings of the cable, or the values specified herein, whichever are more stringent.
- d) The accessories should provide "Double Insulation" so that a single point failure of insulation will not result in the system tripping.

**5.0 THE ABC ACCESSORIES**

The ABC Accessories shall consist of the following:

a)	Insulation Piercing Connectors (IPC)	:	For making tap-off/branch connectors/service connector to an ABC line.
b)	Anchoring Assembly (AA)	:	For fitting onto a pole for anchoring the end of a length of ABC, or for a major change in direction.
c)	Suspension Assembly (SA)	:	For supporting a length of ABC at an intermediate pole in a length, with small angle of deviation.
d)	Service clamp (sc)	:	For anchor Insulated service lines (armoured or unarmour)
e)	Transformer Connections	:	For connection to the transformer bushing.
f)	Junction Sleeves	:	For Phases, neutral messengers & Street lighting conductor.
g)	ABC Service Main Distribution Box	:	For Distribution of multiple no. of Service Connections from Main AB cable.

**5.1 Insulation Piercing Connectors (IPC)**

5.1.1 Insulation Piercing Connectors (IPC) are used for making Tee/Tap-off/Service connectors to an ABC/Bare Overhead Line.

5.1.2 Insulation Piercing Connectors are designed to make a connection between the uncut main conductor and a branch cable conductor without having to strip either cable to expose the conductor instead the tightening action of the IPC will first pierce the Insulation, then make good electrical contact between the main end and branch conductor while simultaneously insulating and sealing the connection.

5.1.3. Constructional Features of IPC

5.1.3.1 The housing shall be made entirely of mechanical and weather resistant plastic insulation material and no metallic part outside the housing is acceptable except for the tightening bolt.

5.1.3.2 Any metallic part that is exposed must not be capable of carrying a potential during or after connector installation.

5.1.3.3 Screws or nuts assigned for fitting with IPC (Insulating Piercing connector), must be fitted with torque limiting shear heads to prevent over tightening or under tightening (min & max torque values to be specified by Manufacturer).

5.1.3.4 The IPC must perform piercing and connection on Main and Branch cable simultaneously.

5.1.3.5 The IPCs shall be water proof and the water tightness shall be ensured by appropriate elastomer materials and not by grease, gel or paste alone.

5.1.3.6 Design of IPC should be such as to not cause damage to insulation of adjacent conductors due to vibration and relative movement during service.



5.1.3.7 The connector shall have a rigid removable end cap which can be slide fitted onto the main connector body on either right or left by the installer (depending on site requirement) for sealing the cut end of the branch cable. Once the connector is fitted, it should not be possible to remove the cap without removing the connector.

5.1.3.8 All the metallic parts of the connector should be corrosion resistant and there should not be any appreciable change in contact resistance & temperature after overloads & load cycling.

- The contact plates should be made of tinned copper/aluminium alloy.
- Connector teeth should be factory greased & sealed to retard water or moisture ingress & corrosion.
- The Insulation material should be made of weather & UV resistant reinforced polymer.
- The outer metallic part should have potential free tightening bolts to allow safe installation on live lines.

**5.1.4 Mechanical Tightening and Electrical Continuity**

5.1.4.1 Connectors shall be tightened upto 70% of the minimum torque indicated by the Manufacturer. At this torque electrical contact should have occurred between conductors to be joined. Then connectors shall be tightened up to the breakdown of the shear heads and lastly, upto 1.5 times the maximum torque indicated by the manufacturer.

For the connector fitted with two screws on the same core, after the breakdown of the shear heads tightening may be carried out manually and alternatively using a torque meter. The test conditions shall be as close as possible to those defined for the use of the test machine as per NF-C standard.

5.1.4.2 At 1.5 times the maximum torque indicated by the manufacturer, there shall be no breakdown of any part of the connector or the core conductor.

5.1.4.3 Maximum rated torque shall not exceed 20 N.m for conductor <95 sq.mm and 30 for >95 but <150 sq.mm.

5.1.4.4 Tightening screws shall have hex. Heads of 10 mm, 13 mm or 17 mm only.

**5.1.5 Effect of Tightening on Main Core of IPC**

5.1.5.1 The connector shall be fitted approx. at the centre of the main core, which is secure between two anchoring points 0.5 mtr. To 1.5 mtr.apart. At the time of fitting the connectors, the main core shall be under longitudinal tension at 20% of the load indicated in Table-1:

<b>Table-1</b>	
<b>Nominal Cross – section (sq.mm.)</b>	<b>Tensile Strength (Newton)</b>
16	1200
25	1800
35	2500
50	3500

70	5000
150	10000

5.1.5.2 Tensile strain shall be increased to the full value indicated in the Table 1 and held minute. There should be no breakdown of the core conductor.

**5.1.6 Effect of Tightening on Branch Core of IPC**

5.1.6.1 Test specimen shall be made up as in clause 5.1.5.1 except that this shall be do the smallest cross sections of main and branch conductors within its range.

5.1.6.2 An increasing tensile load shall be applied to the Branch Conductor along the axis of the recess for the Branch cable. Load shall increase at 100 – 500 N/minute until it reaches the value specified in the Table 2 and maintained for 1 minute.

<b>Table-2</b>	
Nominal Cross – section (sq.mm.)	Tensile Strength (Newton)
16 (Alu)	290
25	450
35 & above	500

5.1.6.3 No slippage or breaking of conductor shall occur.

**5.1.7 Dielectric & Water Tightness Test of IPC**

5.1.7.1 The connector is tightened up to the minimum torque indicated by the manufacturer.

5.1.7.2 Connectors are mounted on

- Minimum cross section of main core.
- Maximum cross section of main core.

5.1.7.3 In each case Branch is of minimum cross section.

5.1.7.4 Protection caps for the branch cable are to be used in accordance with the requirements of clause 5.1.3.7. An additional water tight cap of any design may be used to seal one end of the main cable if it is immersed under water. No additional gel or any protection is to be provided while installing connector.

5.1.7.5 The entire assembly shall be immersed at a depth of approx. 30cms. For 30 minutes with the free ends of main and branch cable out of the water.

5.1.7.6 An AC voltage of 6 kV shall be applied between the water bath and each of the cores in turn for 1 minute. There shall be no flashover or electrical tripping with a trip setting of 10 mA + 0.5mA.

**5.1.8 Electrical & Ageing Test of IPC**

5.1.8.1 Two test configurations are used according to Table 3 with the connections tightened to the minimum torque specified by their manufacturers and resistance recorded.

<b>Table - 3</b>		
Configuration	Main core cross section	Branch core cross section Tensile Strength (K.N)
1st Configuration	Maximum	Maximum
2nd Configuration	Maximum	Maximum

- 5.1.8.2 The configurations are subjected to 200 heat cycles by injecting suitable current into them. In each cycle the temperature of the conductor shall be raised from ambient to 120 + 5°C as, measured by a thermocouple.
- 5.1.8.3 The duration of each heating cycle is chosen to maintain a sufficiently steady temperature of 120 + 5°C for 15 minutes. The duration of each cooling cycle is chosen to bring the conductor temperature to within 2°C of ambient.
- 5.1.8.4 Nominal heating current is indicated in the Table-4. It shall be permissible to accelerate the temperature rise by using a current up to 1.5 times the nominal current and to accelerate the cooling period by use of a fan or air blower.

<b>Table-4</b>	
Nominal Cross – section (sq.mm.)	Nominal Heating Current (A)
16	102
25	139
35	175
50	225
70	283
95	350
120	412
150	480
185	545
240	670

- 5.1.8.5 The over current test of Clause 5.1.9 shall be done after 50 cycles if the connector is a safety connector designed to ground a phase connector while the line is being worked on.
- 5.1.8.6 At the end of the 200 cycles the resistance shall again be measured. It shall not differ from the initial value by more than 12%.
- 5.1.9 Over Current Test of IPC**
- 5.1.9.1 Over current test is required to establish the performance of Safety Connectors that are intended to provide a safe path to ground for the phases while the line is de-energised for working. It establishes the performance of the connector under short term over load conditions.
- 5.1.9.2 After the first 50 cycles of clause 5.1.8, the connectors are subjected to 4 over currents of 1 sec duration each.
- 5.1.9.3 The conductor temperature at the start of the over current test should be not more than 35°C.

5.1.9.4 Current density during over current shall be 100 A/sq.mm for Aluminium and 95 A/sq.mm for Aluminium – Alloy Conductor.

5.1.9.5 Variation in time of over current is permissible between 0.85 sec & 1.15 sec., provided if maintains the relationship  $I^2t$

$$t = K \text{ where,}$$

$$I = \text{rms value of over current in Amps.}$$

$$t = \text{time in seconds}$$

$$K = \text{Constant}$$

5.1.9.6 After the over current test the electrical ageing test of clause 5.1.8 shall be resumed.

**5.1.10 Type Test of IPC**

5.1.10.1 Type Test Reports should be submitted from an Independent Laboratory of Repute or the Works Laboratory in case of a foreign manufacturer covering the following (on any convenient size of fitting of same design made from the same materials).

5.1.10.2 The installation of the connectors shall be done by the laboratory following instructions provided by the manufacturer.

5.1.10.3 The Test report shall record the embossing and marking on the connector.

5.1.10.4 The following shall constitute Type Tests for IPC :

- Electrical Ageing Test
- Dielectric and Water Tightness Test.
- Mechanical Tightening Test
- Effect of Tightening on main Core
- Effect of Tightening on Branch core
- Over-current Test (if applicable)

The following shall be Type Test for Suspension Assembly (SA)

- Mechanical Test
- Voltage Test
- Climatic Aging Test
- Corrosion Test
- Endurance Test under Thermal & Mechanical Stresses

The following shall be Type Tests for Anchoring Assemblies (AA)

- Mechanical Test
- Voltage Test
- Dynamic Test
- Climatic Aging Test
- Corrosion Test
- Endurance Test under Thermal & Mechanical Stresses

**5.2 Anchoring Clamp for Insulated Messenger:**

The clamps should be designed to Anchor LT-AB cable with insulated messenger. The clamp should consists of an Aluminium alloy corrosion resistant castled body, bail of stainless steel and self adjusting plastic wedges which shall anchor/hold the neutral messenger without damaging the insulation.

- No losable part in the process of clamping arrangement
- The clamp should conform to the standard NFC 33041 and 33042 or equivalent I.S. if any.
- The clamp body should be made of corrosion resistant Aluminium alloy, bail should be of stainless steel and wedges should be weather and UV resistant polymer.
- Ultimate tensile strength of the clamp should not be less than 15 km for 50/70sq.mm insulated messenger wire / 10 KN for 25/35 sq.mm insulated messenger wire.
- Slip load of the clamp should not be less than 3 KN for 50/70 sq.mm. messenger wire / 2 KN for 25/35 sq.mm. messenger wire.

5.2.1 Anchoring assemblies are used to firmly attach the messenger of ABC to a support and transmit the mechanical tension.

- at the end of a run or to the supporting structures
- at a major change in direction.

5.2.2 Each Anchoring Assembly shall include.

- One number tension bracket.
- One number wedge type tension clamp
- Flexible Rope for fixing tension clamp to bracket.

5.2.3 Anchoring assemblies shall be supplied in sets to ensure compatibility of the materials against corrosion or wear of moving parts.

5.2.1 Tension Bracket of AA

5.2.4.1 The tension bracket shall be made out of a single piece of Aluminium alloy suitable for attachment to a pole either by

- a) 16mm galvanized steel bolt (s) or
- b) two stainless Steel straps of 20 x 0.7 mm.

5.2.4.2 The tension bracket should be designed to ensure the Flexible rope cannot slip out at any angle.

5.2.4.3 The tension bracket should be rated and tested for the loads specified in Table-5. The load shall be applied at an angle of 45° from the normal to the surface of mounting of the bracket.

<b>Table - 5</b>			
<b>Conductor Size (Sq.mm.)</b>	<b>Rating</b>	<b>Load for deformation &lt;10mm (Newtons)</b>	<b>Load for deformation &lt;30mm &amp; no-break (Newtons)</b>
25-35	1500 Kg.	12,000	15,000
50-95	2000Kg	15,600	19,500

5.2.5 Flexible Rope of AA

5.2.5.1 The Anchoring assembly shall be supplied with a stainless steel flexible Rope to connect the Tension Clamp to the Tension Bracket.

5.2.5.2 The rope should have sufficient flexibility to ease the torsional movement of the ABC System.

5.2.5.3 The Rope should be pre-fitted with compression type end fittings to secure the tension clamp.

- 5.2.5.4 A wear resistant moveable saddle should be un-loosably fitted on the Rope to prevent abrasion at the point of fitting into the tension bracket.
- 5.2.5.5 The Rope should have sufficient mechanical strength to withstand the mechanical test for the complete assembly tests in this specification.
- 5.2.6 Wedge Type Tension Clamp of AA
  - 5.2.6.1 Wedge type clamps shall be used for clamping the messenger without damaging the insulation.
  - 5.2.6.2 The clamp shall be capable of clamping an uncut messenger so that it can continue without break to the connecting point or next span.
  - 5.2.6.3 The clamp shall be fully insulating type of mechanical and weather resisting thermoplastic.
  - 5.2.6.4 No bolts or loose parts are allowed as part of the Clamping system.
  - 5.2.6.5 No tools shall be needed for fitting the messenger into the clamp.
  - 5.2.6.6 The clamp shall be self tightening and capable of holding without slippage the load specified in the Table-6.

<b>Table - 6</b>				
Conductor Size		Rating (Kg.)	T start (I minute) (Newtons)	T final (I minute) (Newtons)
Sq. mm.	Dia. (mm)			
25-35	8-11	1000 Kg.	8,000	10,000
50-54	8-11	1500 Kg.	12,000	15,000
70-95	13.5-16	2000 Kg.	12,000	15,000

- 5.2.6.7 After fitting the insulated messenger in the clamp, load T start will be held for 1 minute & then load increased to T final at rate between 5000 – 7,500 N/mtr. In each case there shall be no breakdown of any part of clamp and slippage of messenger in relation to the clamp.
- 5.2.7 Voltage Test on Clamp of AA
  - 5.2.7.1 Voltage test is carried out on anchor clamps to ensure no damage is caused to the insulated messenger.
  - 5.2.7.2 A conductive rod of dia. corresponding to the average dia. that can be accommodated in the clamp is fitted into the clamp, protruding by approx. 50mm at each end of the tightening piece.
  - 5.2.7.3 The rod and clamp is subjected to tensile load as stated in Table 7 below when fixed to a support in its normal manner.

<b>Table - 7</b>			
Conductor Size		Normal rating (kg)	Load Applied (N)
Sq. mm.	Dia. (mm)		
25-35	8-11	1000	2000
50-54	8-11	1500	4000
70-95	13.5-16	2000	4000

- 5.2.7.4 A power frequency voltage of 6 kV is applied for 1 minute between the rod and conductive part of the clamp, or fixation point in absence of conductive part.

5.2.7.5 No breakdown or flashover shall occur. There shall be no tripping due to leakage with a setting of 10 + 0.5 mA.

5.2.8 Endurance under Mechanical & Thermal Stress of AA

5.2.8.1 This test is done on clamp rated 1500 Kg. or 2000 Kg. using insulated messenger 50 to 70 sq. mm.

5.2.8.2 A neutral messenger is fitted between two anchor clamps, with clamp spacing approx. 5 mtr. & 1 mtr. Of messenger protruding from the end. Marks are made to enable measurement of slippage.

5.2.8.3 The sample is subjected to 500 cycles of 90 minutes each as described below:

5.2.8.3.1 Messenger temperature is raised by passing an AC current to 60 +30 C within 15 minutes. This temperature is maintained for at least 30 minutes to give a total heating period of 45 mts.per cycle.

5.2.8.3.2 Messenger is allowed to cool naturally to ambient for further 45 minutes to complete 90mts. Cycle time.

5.2.8.3.3 Mechanical load is applied during the cycle as per table 8 below. Load F1 is applied throughout the cycle, except for a short period of 5 sec. to 60 sec. when it is gradually increased from F1 to F2 at any time during the last 15 minutes of the 90 minute cycle.

<b>Table - 8</b>				
Conductor Size		Rating (Kg.)	F1 (Newtons)	F2 (Newtons)
Sq. mm.	Dia. (mm)			
25-35	8-11	1000 Kg.	2,200	5,000
50-54	8-11	1500 Kg.	4,000	7,500
70-95	13.5-16	2000 Kg.	4,500	10,000

5.2.8.3.4 There should be no slippage greater than 4 mm after 2 cycles or greater than 8 mm after 500 cycles.

5.2.8.3.5 Voltage test is done at the end of the 500 cycles by immersing the test specimen of neutral messenger and clamps in water of resistivity not less than 200 Ohm mtr. For 30 minutes.

5.2.8.3.6 A voltage of 10 kV ac is applied for 1 minute between messenger and water bath using a trip setting of 10 + 0.5 am. There should be no breakdown or tripping.

5.3 Suspension clamp for insulated neutral messenger:

The clamp should be designed to hang L.T – AB cable with insulated neutral messengers. The neutral messengers should be fixed by an adjustable grip device. A movable link should allow longitudinal and transversal movement of the clamp body.

- No losable part in the process of clamping arrangement.
- The clamp should conform to the standard NFC 33040 or equivalent I.S, if any.
- The clamp and the link made of Polymer should provide an additional insulation between the cable and the pole.
- The clamps and movable links should be made of weather and UV resistant glass fibre reinforced polymer.
- Clamps should be fixed with pole by eye hook / bracket. Bracket should be made of corrosion resistant aluminium alloy.
- Ultimate tensile strength of the clamp should not be less than 15 KN for 50/70 sq.mm. Insulated messenger wire 4.3 KN for 25/35 sq.mm. Insulated messenger wire.
- Maximum allowable load of the clamp should not be less than 20 KN for 50/70 sq.mm. insulated messenger wire/15 KN for 25/30 sq.mm insulated messenger wire.

5.3.1 Suspension Assembly is used for supporting an ABC by installation on the messenger at an intermediate point of support such as a pole. It can accommodate small angles of deviation upto 30°.

5.3.2 Each Suspension Assembly shall consist of:

- One number Suspension Bracket.
- One number moveable (articulated) connecting link.
- One number Suspension Clamp.

5.3.3 Suspension Assemblies shall be supplied in sets to ensure compatibility of the materials against corrosion or wear of rotating/moving parts.

5.3.4 Suspension Bracket of SA

5.3.4.1 The Suspension Bracket shall be made from single piece alluminium alloy suitable for attachment to a pole by either.

- a) 16 mm galvanized steel bolt or
- b) Two stainless steel straps.

5.3.4.2 The Suspension Bracket shall be provided with an upper bulge to prevent the clamp from turning over on the Bracket for more than 45 O from the horizontal or to within less than 60 mm from the pole / fixing structure.

5.3.4.3 The Suspension Bracket should be so designed to ensure that the articulated link cannot slip out of it.

5.3.4.4 Suspension Brackets shall be designed to withstand a load applied at the anchoring point of the movable link as per Table – 9 below without deformation of more than 10mm or breakdown at 330 below horizontal (there should be no longitudinal component of load parallel to the plane of fixing).

<b>Table - 9</b>			
Conductor Size		Normal rating (kg)	Load (N)
Sq. mm.	Dia. (mm)		
25-35	8-11	1500Kg.	12500
70-95	13-17	2000Kg.	14000

5.3.5 Movable (Articulated) Link of SA

5.3.5.1 Movable Links are used between the Suspension Bracket and Suspension Clamp to allow a degree of movement and flexibility between the two.

5.3.5.2 Moveable Links should be made fully of insulating type of mechanical and weather resistant thermoplastic. A metallic wear resistant ring should however be fitted at point of contact between the Suspension Bracket and the movable link.

5.3.5.3 The Movable link should be unloosably fitted to the Bracket and the Clamp.

5.3.6 Suspension Clamp of SA

5.3.6.1 Suspension Clamps are used for locking the messenger of the ABC bundle without damaging the insulation or allowing the messenger to become dismounted from the fitting.

5.3.6.2 The Suspension Clamp shall accommodate messenger wires from 25 to 95 sq.m.

5.3.6.3 The Suspension Clamp shall be made fully of insulating type of mechanically strong and weather resistant plastic.



- 5.3.6.4 Bolts should not be used for clamping / locking the messenger in the Clamp.
- 5.3.6.5 There shall be no losable parts in the Suspension clamp.
- 5.3.6.6 The Suspension Clamp should be unloosably fitted to the rest of the Suspension Assembly.
- 5.3.7 Mechanical Test on Clamp of SA
- 5.3.7.1 The Sub Assembly shall be subjected to a vertical load applied as per drawing in accordance with Table-10. There shall be no breakdown or permanent deformation at load T initial for 1 minute or when the load is increased to T final and released.

<b>Table - 10</b>				
Conductor Size		Rating (Kg.)	T start (I minute) (Newtons)	T final (I minute) (Newtons)
Sq. mm.	Dia. (mm)			
25-54	8-15	1500 Kg.	9,600	12,000
70-95	13-17	2000 Kg.	12,800	16,000

Fig. : A

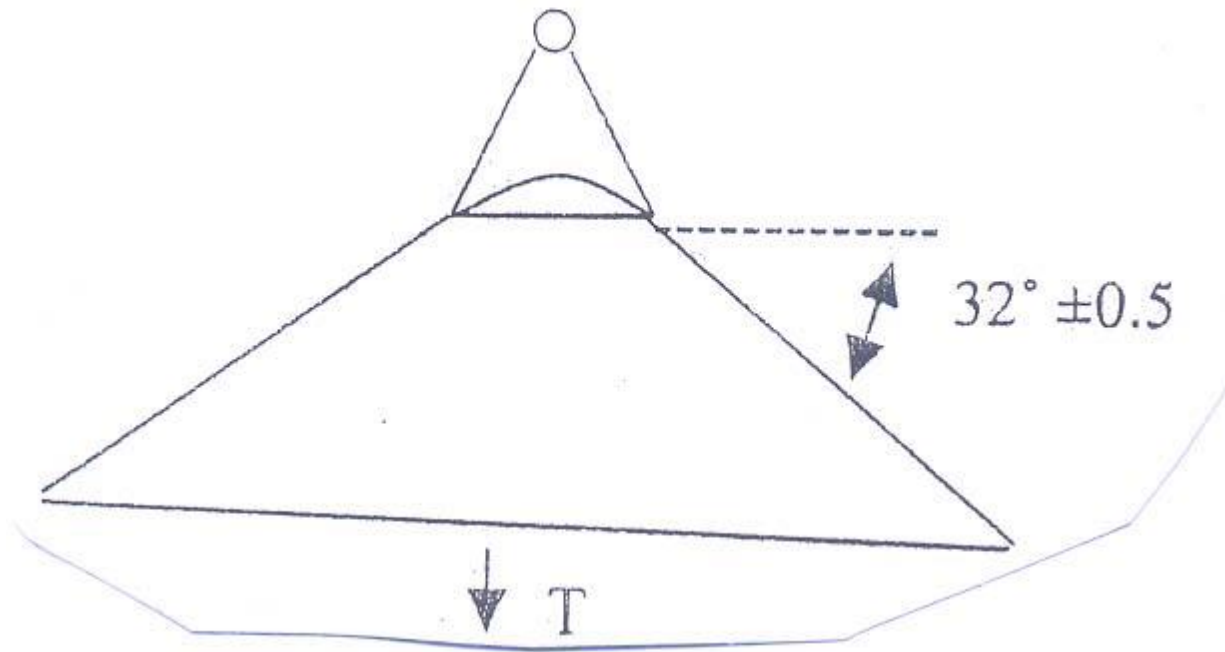

- 5.3.7.2 A sample messenger shall be fitted into a fixed suspension clamp and subjected to a gradually applied longitudinal load of 300 N. There shall be no permanent slip page.

- 5.3.8 Voltage Test of SA  
 A copper foil is wrapped at the clamping point around the maximum size of messenger allowed in that clamp. An ac voltage of 6 KV is applied between the copper foil and nearest conductive point of the clamp or into its absence to the point of fixation. The voltage should be withstood for 1 minute without breakdown or flashover.
- 5.3.9 Test Under Mechanical & Thermal Stress
- 5.3.9.1 The test specimen is made up of approx. 10mts. Of messenger wire strung between two anchor clamps with a Suspension Clamp fixed in the middle. Masses of 40 Kg. are suspended at a distance of 1-2mtr. On either side of the Suspension Clamp with a fixing mechanism of mass 2 + 1 Kg.
- 5.3.9.2 The specimen is subjected to 500 cycles of 90 minutes each. Each cycle consists of the following:
- a) For first 75 minutes a constant longitudinal tension of 4000 N is applied to the messenger for rating of 1500 Kg. and of 4500 N rating of 2000 Kg. while 64cycles right and left oscillation are produced on the clamp 32°on either side of the vertical.
  - b) During the first 45 minutes an intermittent current of 4-5 A/sq.mm is applied to maintain the conductor temp at 60 + 3° C.
  - c) During the next 45 minutes of the cycle the conductor is allowed to cool down naturally to the ambient.
  - d) At the 75th minute, after having completed 64 oscillations, the oscillations are stopped and the longitudinal tension is increased to 7500 N for 1500 kg. Rating and 10000 N for 2000 Kg. Rating.
- 3.9.3 No messenger slippage should occur within the Suspension Clamp during the 500cycles.
- 5.3.9.4 At the end of the 500 cycles, the messenger is immersed in water for 30 minutes. It is then tested to withstand 10 kV ac for 1 minute with a trip setting of 10 + 0.5 mA. There should be no breakdown or flashover.

#### 5.4 **Acceptance Tests**

- 5.4.1 The following shall constitute Acceptance Tests for Insulation Piercing Connectors(IPC) :
- Visual \*
  - Dimensional (as per SCD and overall dimensions submitted with Tender Offer)\*
  - ~~Electrical Ageing Test \*\*\*~~
  - Dielectric and Water Tightness Test. \*\*
  - Mechanical Tightening Test \*\*
  - Effect of Tightening on Main Core \*\*
  - Effect of Tightening on Branch Core \*\*

The above tests are to be carried out as per sampling plan below. ~~However electrical ageing test on IPC (market\*\*\*) is to be done on only one connector of each type and size.~~

In case of random failure/defect, double the sample lot is to be drawn and there should be no failure/defect exceeding half the permissible defects (rounded down) shown in the chart.

Lot Size	For tests Marked*		For tests Marked**	
	Sample Size	Max. permissible Defects	Sample Size	Max. permissible Defects
Upto 100	2	nil	2	nil
101 to 1000	6	nil	4	nil
>1001	0.01% subject to min. 6 pieces	0.1% of pieces checked	4	nil

5.4.2 The following shall constitute acceptance tests for Anchor Assemblies:

- Visual \*
- Dimensional (as per SCD and overall dimensions submitted with Tender Offer)\*
- Mechanical Test on Bracket\*\*
- Mechanical Test on Clamp \*\*
- Voltage Test \*

5.4.3 The following shall constitute acceptance tests for Suspension Assemblies:

- Visual \*
- Dimensional (as per SCD and overall dimensions submitted with Tender Offer)\*
- Mechanical Test on Bracket\*\*
- Mechanical Test on Clamp \*\*
- Voltage Test \*

The above tests (for AA & SA) are to be carried out as per sampling plan below. In case of random failure/defect, double the sample lot is to be drawn and there should be no failure/defect exceeding half the permissible defects (rounded down) shown in the chart.

Lot Size	For tests Marked*		For tests Marked**	
	Sample Size	Max. permissible Defects	Sample Size	Max. permissible Defects
Upto 100	2	nil	1	nil
101 - 500	5	1	2	nil
501 - 2500	10	2	2	nil
2501 & above	10 + 0.2 %	2 + 10% pf addl. Sample quantity	4	1

**6.0 SERVICE CLAMP**

The clamps should be designed to anchor insulated service lines (armoured or unarmoured) with 2/4 conductors.

- The clamps should be made of weather and UV resistant polymer.
- No losable part in the process of clamping arrangement
- The clamp should conform to the standard NFC 33042 or equivalent I.S., if any. No losable
- Breaking Load of the clamp should not be less than 3 KN.

## **7.0 TRANSFORMER CONNECTION**

- The connection to the transformer should be made with Pre-Insulated lugs for phase and street lighting conductors and with an Aluminum Lug for neutral Messenger. If the Bus-bars are of copper, the Lugs should be preferably Bi-metallic type.
- The Barrel of the lug normally insulated with an Anti-UV black Thermoplastic tube sealed with a flexible ring. Die reference, size and strip length are to be indicated on the plastic.
- Sizes covered 16-70 & upto 150 m<sup>2</sup> Aluminium XLPE insulated cable.
- Reference standard NFC 33021 or equivalent I.S. if any.

## **8.0 JUNCTION SLEEVES**

- The sleeves should be Pre-Insulated for phases, neutral messengers and street lighting conductors.
- Sleeve should be made of Aluminum, insulated with an Anti-UV black thermoplastic tube hermetically sealed two ends with 2 flexible rings.
- Die reference, size and strip length are indicated on the sleeve itself.
- Sizes needed : 16-70 & upto 150 mm<sup>2</sup> for Aluminum XLPE insulated cable.
- Reference standard : NFC 33021 or equivalent I.S. if any.
- Design as per furnished drawing.

## **9.0 EYE HOOKS**

- Eye hooks should be designed as to hold suspension clamps and Dead end clamps and to be installed with the pole clamp.
- Eye-hooks should be made of forged Galvanized steel.
- The clamps corrosion resistance should conform the standards I.S. 2629 & I.S.2633.
- Bolts and nuts should be made of hot dip Galvanized steel according to VDE 0210 and VDE 0212.
- Ultimate Tensile strength (UTs) of the clamp should 20 KN.
- Design as per furnished drawing.

## **10.0 SERVICE MAIN DISTRIBUTION BOXES**

### **10.1 Scope**

This Distribution Box should be Weather & Moisture Proof with Spring loaded/Bolt& Nut type Bus Bar system & should be able to carry a current according to specified capacity. It can have 1/3-phase input & provision of 4 to 6 nos. of 3-phase or 1-phase outputs. The box should have the provision for special key for locking & Proper arrangement of sealing. The boxes should be assembled on the pole using Metal Tapes & Buckles or Bolts. No. of Boxes per pole may vary with supporting arrangement for more no. of service connections. The Spring used should be of stainless steel having required capacity to provide suitable pressure in the connector.

### **10.2 Construction**

Distribution Boxes should be designed with Bus Bars with spring action contact, or screw-bolt technique. For spring action contact only insertion of the conductor into the specified groove of the Busbar is sufficient for proper connection whereas for Nut Bolt type proper washers & other accessories are to be provided for connections. It should be used for multiple connections (3-phase or 1-phase) in low voltage Distribution Network. The boxes should be suitable for 1/3-phase (4 crores) inputs & provision for 4 to 6 nos. of 3-phase or 1-phase outputs. Bus bars should be with a continuous pair of contact bars with colour code to facilitate the identification of the correct energy phase.

The box should be able to incorporate the input or output cable dia. Of maximum 16mm. (Equivalent to 120Sq.mm.).

The Boxes should consist of special type Lock & key system as well as provision for sealing for complete protection of the service connection contacts.

**10.3 Current Ratings**

The maximum current rating should be 140A/200A/250A & concerned authority should have the liberty to choose among the above ratings as per their requirement.

**10.4 Voltage Ratings:**

The maximum voltage withstand capacity should be 600V.

**10.5 Working Temp**

Safe working temperature should be around 80 C for Outer Box & 100OC for metallic Bus bars.

**10.6 Materials**

Material used in the manufacturing process of the components of this product should be specified in the respective product drawings & can be summarized as follows :

- Outer Box (Base & Cap) : With UV protection & Flame retardant characteristics(HB, as per UL 94- Tests for Flammability of Plastic materials) & preferably made up of ASA (Acylnitrile Styrene Acrylate).
- Cable Grommets : Ethylene-Propylene Rubber :
- Safety Key : PA 6.6 (Nylon).
- Safety Screw : Stainless Steel or Plating Finished steel.
- Insulation protection as per IP 44.
- Bus bars or Terminal Blocks : PA 6.6 (Nylon), Stainless Steel & Copper.
- Button & Cable Holder : PA 6.6 (Nylon) with 50% Glass Fibre.
- Busbar Insulation :Polymide.

**10.7 Locking System**

The boxes should consist of Special type Lock & Key arrangement as well as provision for sealing for complete protection of the service connection contacts.

**11.0 G.A. DRAWINGS ETC.**

**11.1** A drawing / picture clearly showing principal parts & dimensions for all products should be submitted along with the offer.

**11.2** The principal outer dimensions of each item, l x b x w in mm and weight in gms should be submitted along with the offer.

**11.3** The Employer may call for samples for verification & evaluation purposes.

**12.0 GENERAL CONDITIONS OF MANUFACTURE**

**13.0 GTP**

The Guaranteed Technical Particulars should be filled up in the given format of GTP.

**14.0 TESTING STANDARD – Given in Annexure 2 & 3.**

- Note :
- 1) Any specific meteorological data other than those listed above applicable for a particular equipment/item will be available in the technical specification for that equipment/item.
  - 2) When values specified above contradicts with respective equipment TS, the later will prevail for that equipment.
  - 3) The atmosphere in the area is laden with industrial and town gases and smoke with dust in suspension during the dry months and subject to tough colder months.
  - 4) Heavy lightning is usual in the area during the months from May to November.

**ANNEXURE-1**

**GENERAL CONDITIONS FOR MANUFACTURE**

The products shall be in accordance recognized standards used in L.T. ABC or equivalent I.S., if any.

Marking	:	Each product shall be clearly identified with manufacturer name or trade mark, reference and capacity of the item and batch no.
Packaging	:	Manufacturer shall mention the packaging of each item. Installation instruction should be included in packaging.
Type test	:	Each supplier should provide type test reports with the offer, carried out in accordance with one of the reference standards in NABL Accredited Laboratory.
Routine test	:	Supplier shall provide a control plan, which will be implemented on each item. Routine test reports should be submitted by the manufacturer with inspection call.
Quality	:	All suppliers should preferably be ISO-9000 certified.

Anchoring and suspension clamps should be installable on existing poles using appropriate devices (hooks, pigtails, brackets etc.).

All crimped connectors should be installed with mechanical or hydraulic hand crimping tools.

**ANNEXURE – 2**

**TESTING STANDARDS :**

The Insulating Piercing Connector should conform to following std. :

<b>Tests</b>	<b>Tests Standard / Test Procedure</b>
Corrosion Qualification Test	<p>As per NF C 33-020 (Jun '98), or equivalent I.S., if any.</p> <p>Exposure in Saline Environment : The exposure should be carried out as per NF en 60068-2-11 (Aug. '99) std. requirement. The concentration of Saline solution must be of 5% <math>\pm</math> 1% in mass, &amp; the temperature of the test chamber must be maintained at 35°C <math>\pm</math> 2°C.</p> <p>Exposure in Sulphur environment saturated of humidity – The exposure should be carried out as per NF T 30-055 (Mar. '74) std. requirement. SO<sub>2</sub> concentration in the chamber should be 0.067% in volume. The temperature of the test chamber should be increased to 40°C <math>\pm</math> 3°C.</p> <p>The total test should include four identical periods of 14 days, in which 7 days of exposure in Saline environment &amp; in other 7 days – 8 hrs. cycles in SO<sub>2</sub> environment &amp; 16 hrs. in laboratory environment.</p>
Electrical Ageing Test	<p>As per NF C 33-020 &amp; NF C 33-004 (Jun '98) or equivalent I.S., if any.</p> <p>Total no. of cycles 200, Heating time -60 mins., Cooling time -45 mins., Pause time – 2 mins.</p>
Dielectric Investigation Test in water	<p>As per NF C 33-020 (Jun '98) or equivalent I.S., if any. 15°C &amp; 30°C &amp; relative humidity between 25% &amp; 75%. The tightening of the connectors should be at minimal value of the torque indicated by the manufacturer. The sample should be placed in tank full of water on 30 cm height, after an immersion length of 30 mins. The set is subjected to a dielectric test under a voltage of 6 KV at industrial frequency during 1 min. No flashover / breakdown should occur at 6 KV during 1 min.</p>
<b>Tests</b>	<b>Tests Standard / Test Procedure</b>
Mechanical Tests	<p>As per NF C 33-020 (Jun '98) or equivalent I.S., if any.</p> <p>For checking electrical continuity, shear heads &amp; mechanical behaviour of the connector's suitable tests as per the above specification have to conduct.</p>



**Capacity needed :**

For ABC 16 to 95 mm<sup>2</sup>

Model 1 for customer service

Main 16 to 95 mm<sup>2</sup>

Tap 2.5 to 10 mm<sup>2</sup> (For Street lighting/service connection)

Design as per furnished drawing

Model 2 for customer service

Main 16 to 95 mm<sup>2</sup>

Tap 04 to 35 mm<sup>2</sup> (for distribution box charging)

Design as per furnished drawing

Model 3 for customer service

Main 25 to 95 mm<sup>2</sup>

Tap 25 to 95 mm<sup>2</sup> (For ABC to ABC Tee Joint)

Design as per furnished drawing.

**ANNEXURE – 3**

**TESTING STANDARDS**

Impact Resistance should be according to UL 746C. Insulation Protection should be as per IP 44. The Outer Plastic box should conform to following std. –

<b>Test / Standard</b>	<b>Requirements</b>	<b>Test Procedures</b>
Degree of Protection IEC 60529	IP 44 – Protected against the penetration of solid objects exceeding 1.0mm in diameter and against penetration of water jets that may affect the product operation.	First Digit : A 1.0mm diameter test wire should not penetrate in any apparent opening (force = 1 N ± 10%)  Second Digit : A spray nozzle is used to spread a water jet in all possible directions.
Impact Resistance UL 746-C	After the test the product should not show any evidence of : - Live electrical parts accessible to the test probe, as described in this test specification. - Any results, which may affect the mechanical performance of the product. - Any results, which may increase the probability of electrical shocks.	The impact should be generated by dropping a steel ball – with a diameter of 50.8 mm and a mass of 0.535 kg – from a specified height sufficient to produce an impact energy of 6.8 J (0.69 13 kg.m.)
UV Resistance UL 746-C	The sample physical properties average value after an accelerated aging with UV radiation – should not be lower than 70% of its initial value,	According to ASTM G26, Exposure Method 1, Xenon Arc Lamp Type B or ASTM G 155, Exposure Cycle I, with continuous
	without aging, that is, a variation of + 30% is allowed.	exposure to light and intermittent exposure to water jets, with programmed cycles of 120 minutes, consisting of a 102 minutes light-only exposure

<b>Test / Standard</b>	<b>Requirements</b>	<b>Test Procedures</b>
		and a 18 minutes exposure to light and water jets.
Withstanding Voltage UL 746-C	Product should withstand the specified voltage	A 5 kV voltage should be applied to the samples after the 40 hours conditioning cycle at $23 \pm 2^{\circ}\text{C}$ and $50 \pm 5\%$ relative humidity plus 96 hours at $35 \pm 2^{\circ}\text{C}$ and $90 \pm 5\%$ relative humidity.
Flammability UL 94	After the UV radiation accelerated aging, the material should maintain the same original flammability level (HB).	The test can be applied to test samples molded with the same material used for the base and the cap of the box or taking a piece of these components.
Flexural Strength ASTM D790 UL 746-C	After UV radiation accelerated aging, the average value for this test should not be lower than 70% of the original value, that is, a maximum variation of 30% is allowed.	A group of test samples without aging should be tested and the average values calculated. Another group should be aged under UV radiation then it should be tested and the new average should be calculated and compared to the initial average value.
Tensile Strength ASTM D638 UL 746-C	After aging with UV Radiation, the average value should not be lower than 70% of the initial values, that is, a maximum variation of 30% is allowed.	One of the test bodies must be tested without being submitted to accelerated aging and is computed over mean values. Another group is submitted to the radiation induced aging and then tested and the new mean value is computed and compared to the first computed mean value.

**ANNEXURE-A**

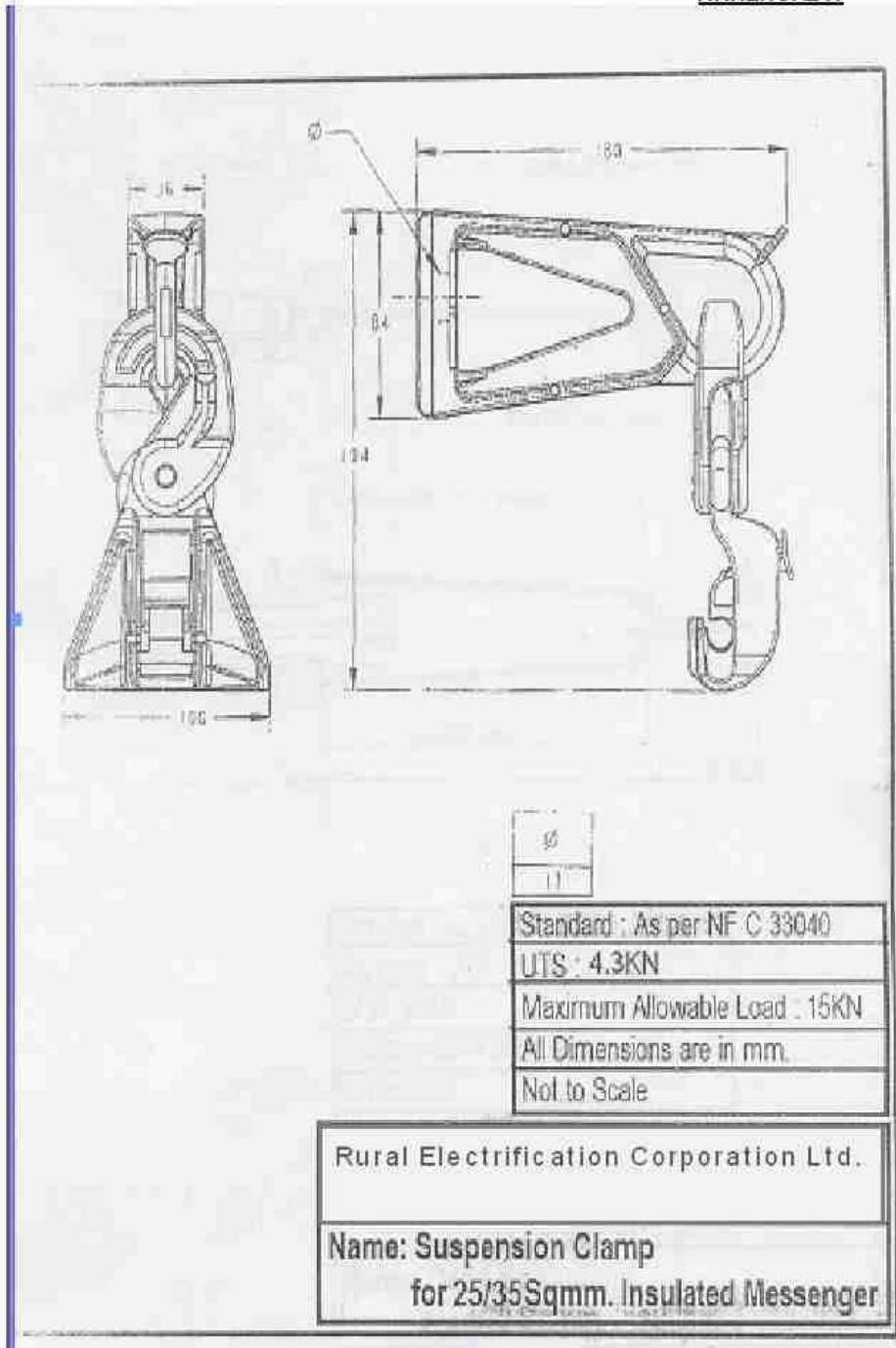

**ANNEXURE-B**

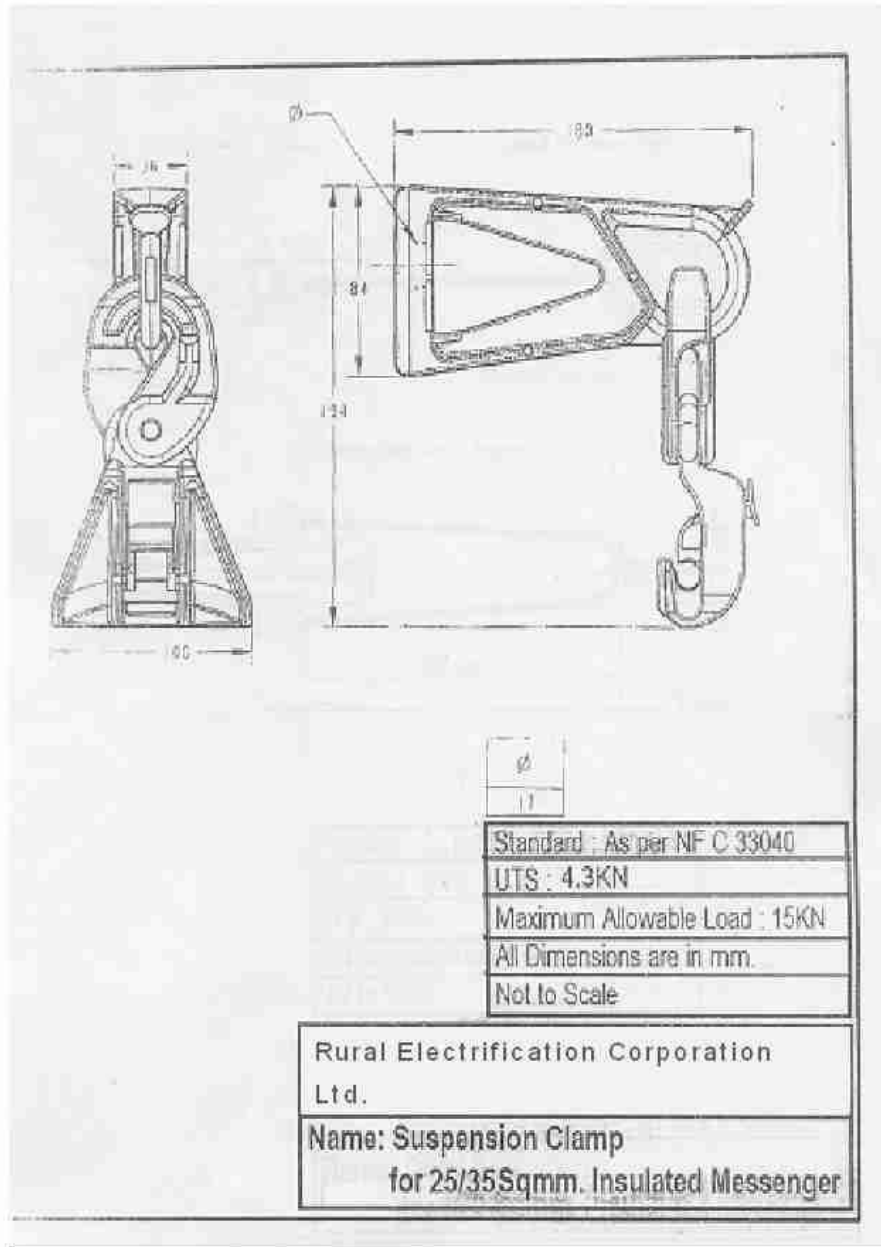

**ANNEXURE-C**

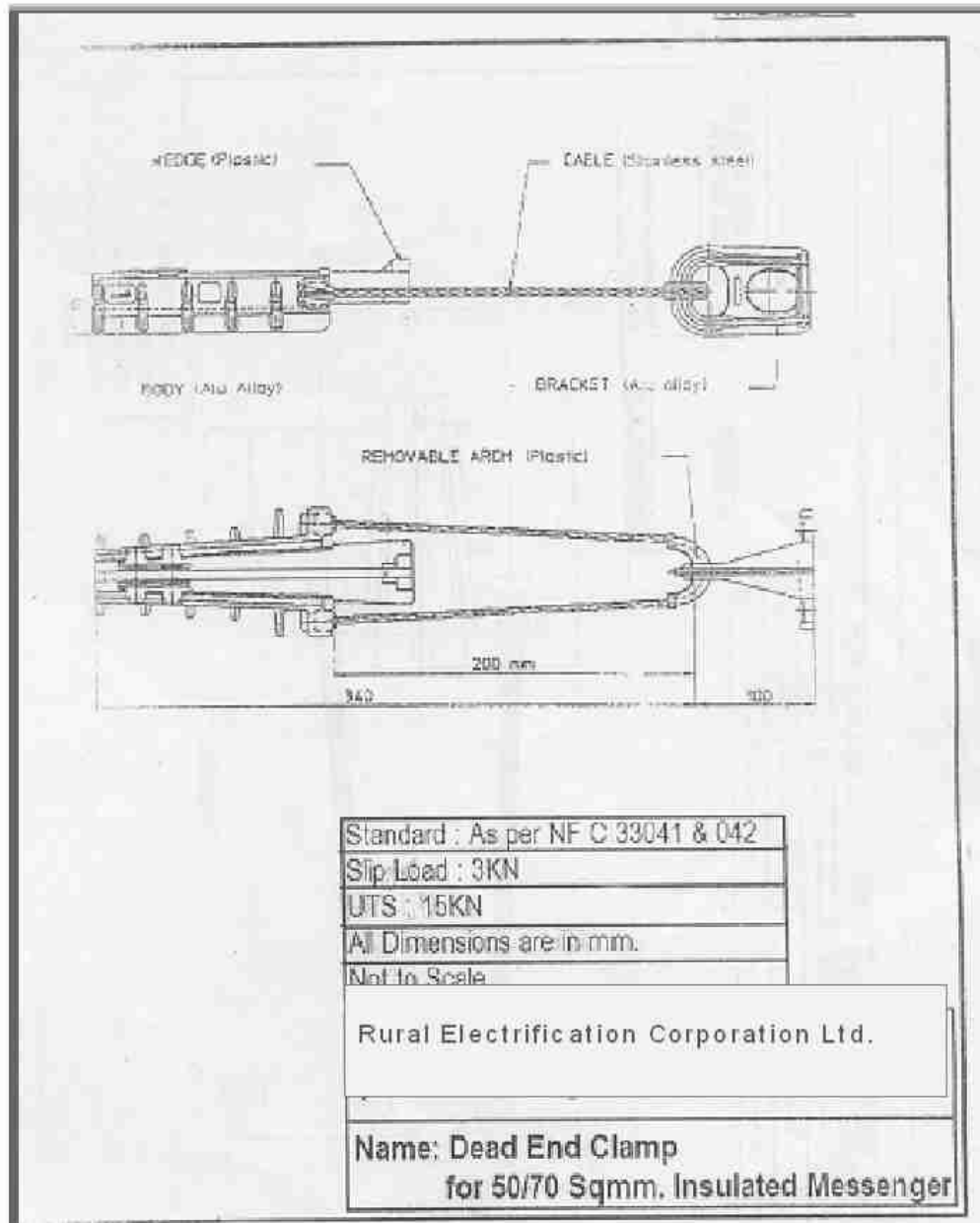

**ANNEXURE-D**

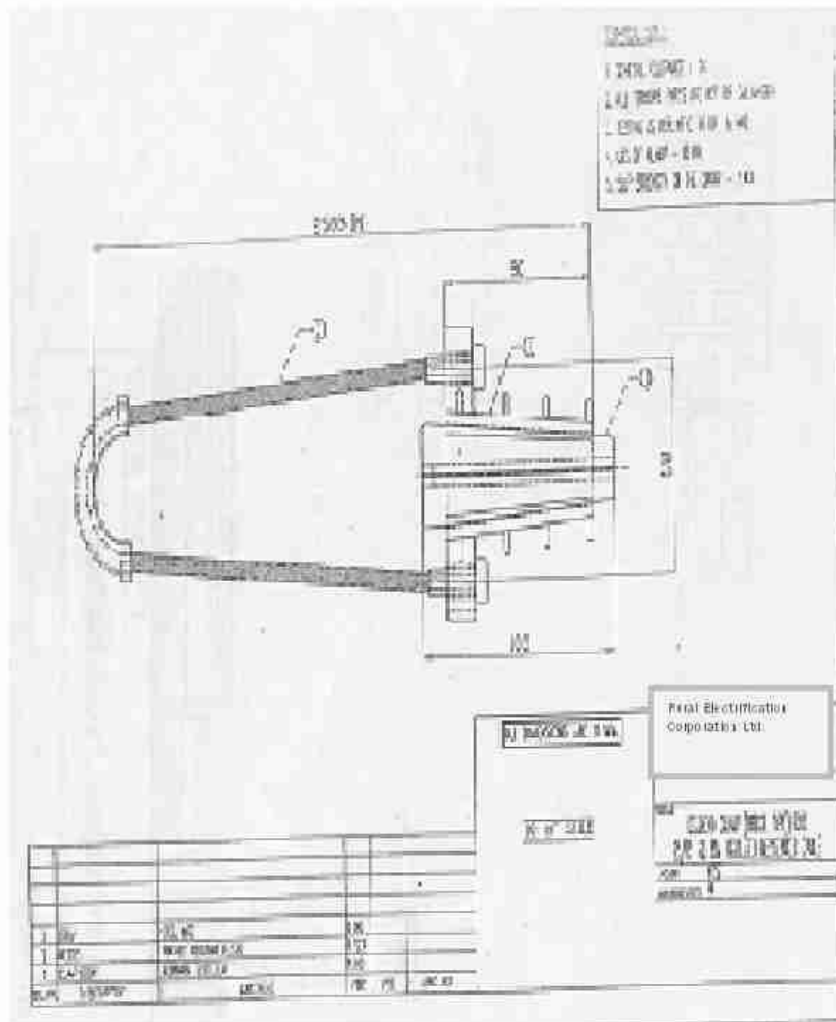

**ANNEXURE-E**

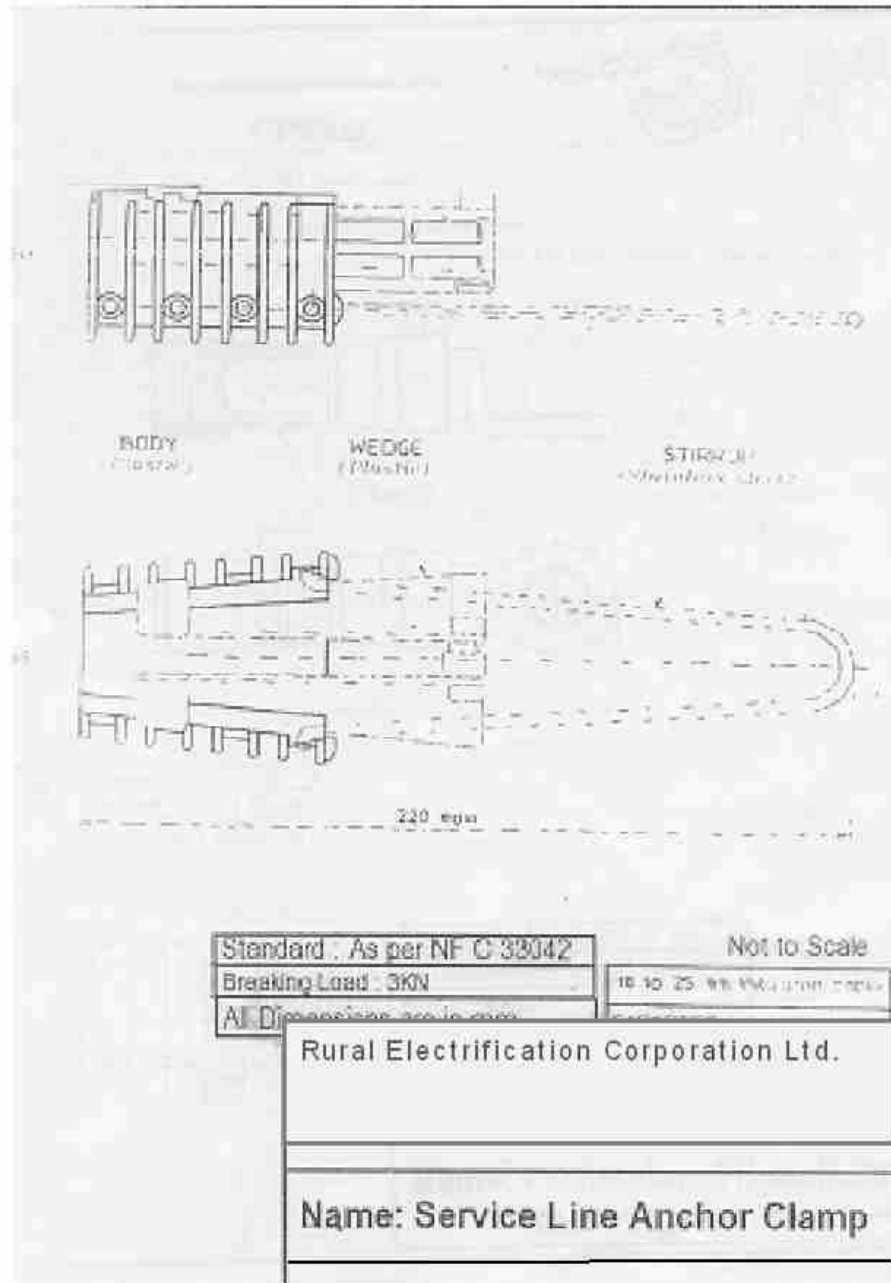



**ANNEXURE-F**

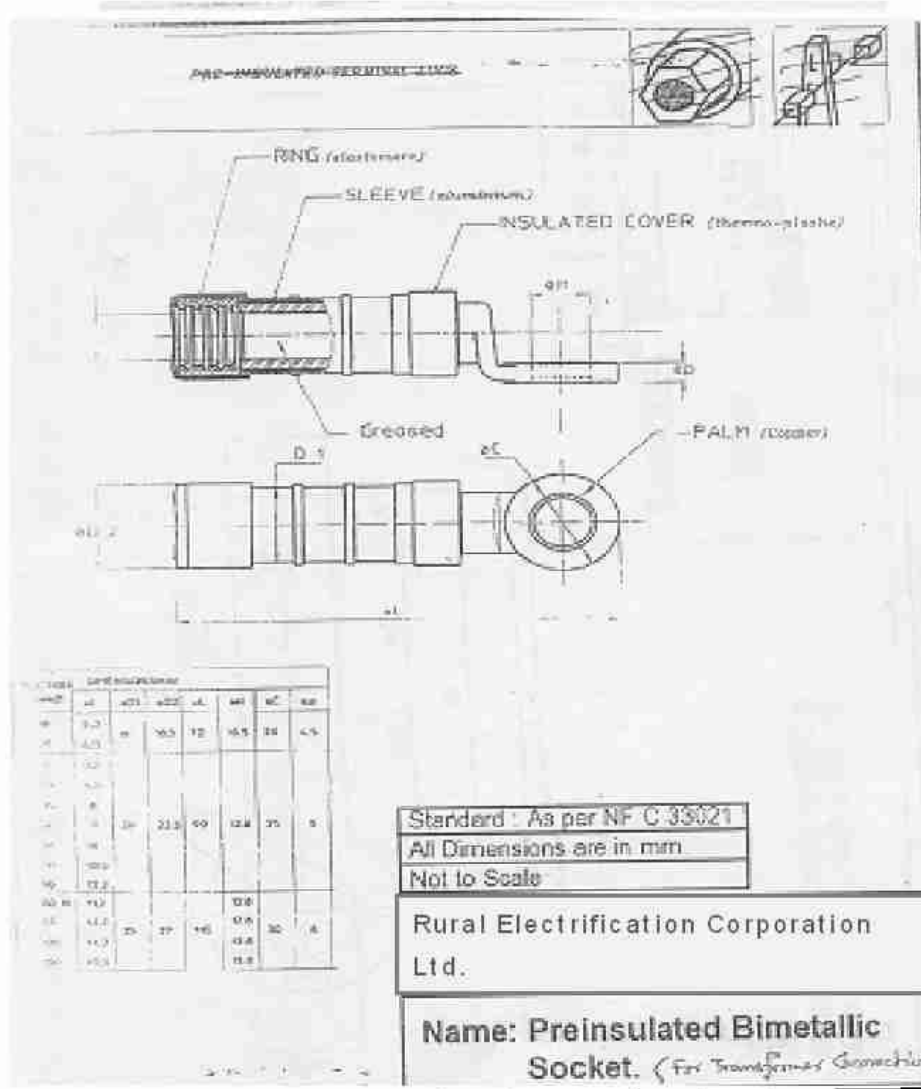

**ANNEXURE-G**

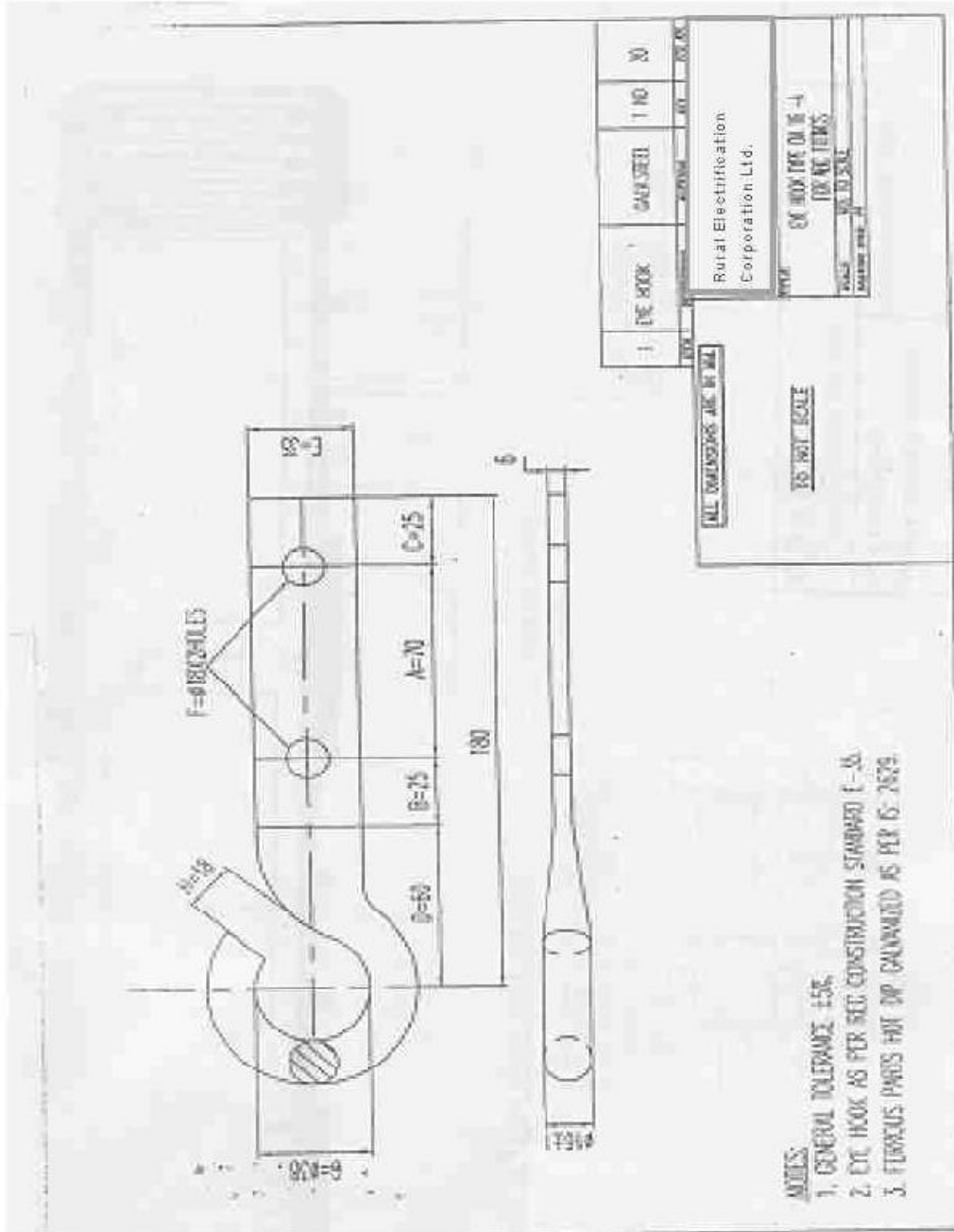

**ANNEXURE-H**

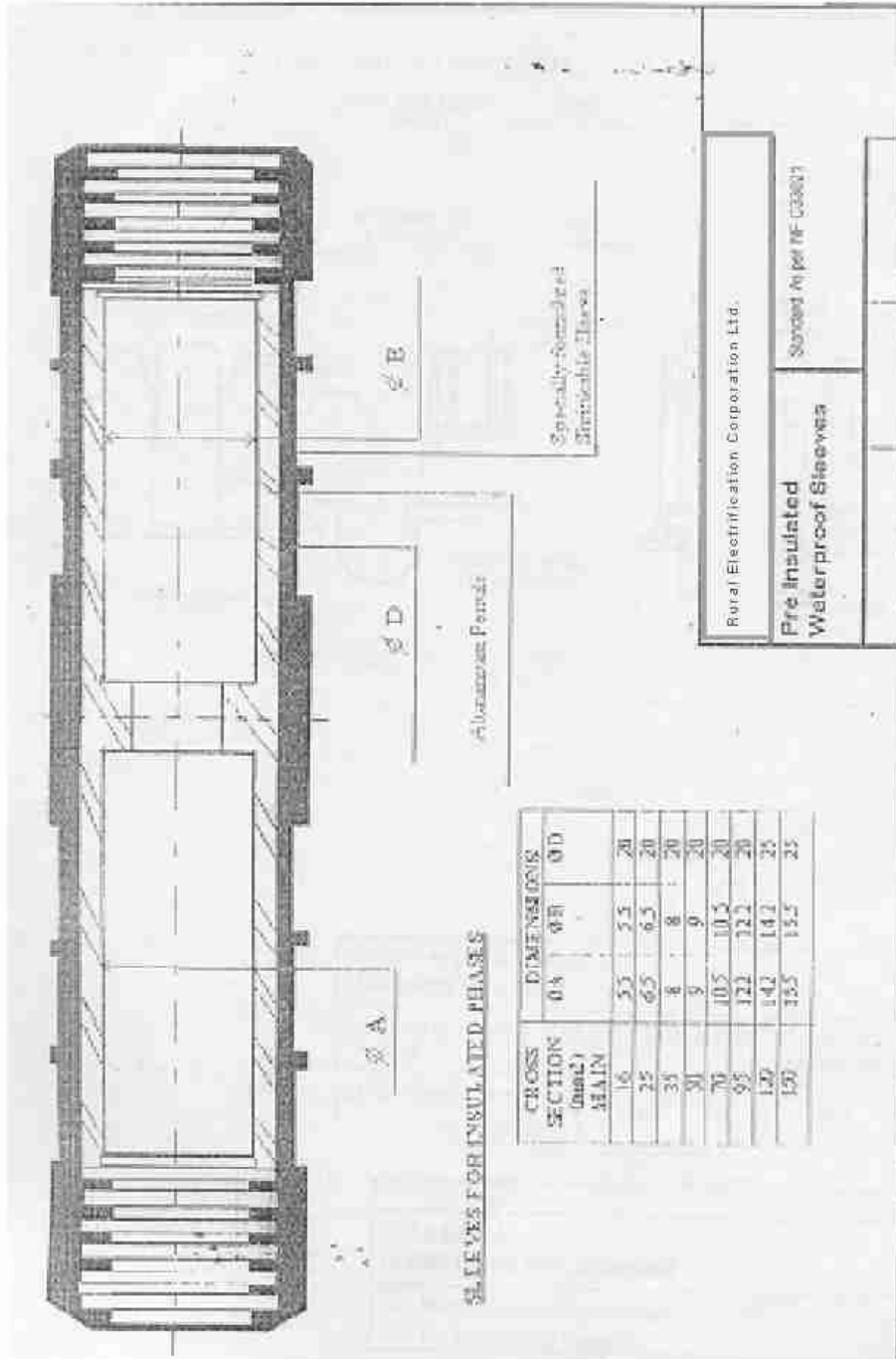

Rural Electrification Corporation Ltd.  
**Pre Insulated Waterproof Sleeves**  
 Standard As per IEC-60801

**ANNEXURE-I**

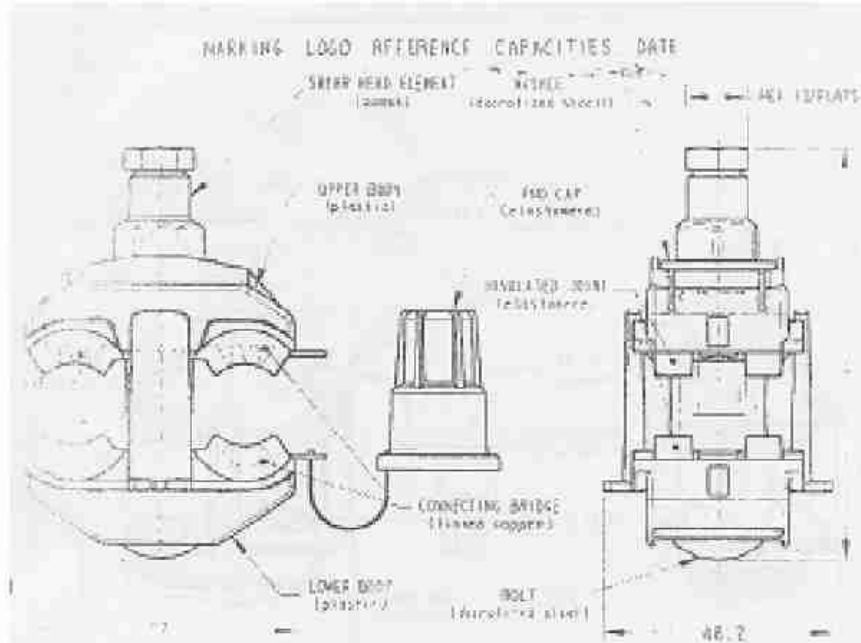

Standard: As per IS: C 33020  
 All dimensions are in mm.

CAPACITIES MAIN	CAPACITIES TAP	WEIGHT	DIMENSIONS	BREAKING SHEAR HEAD TORQUE
25 to 95mm <sup>2</sup>	25 to 95mm <sup>2</sup>	437g	91mm	16Nm

DESIGNED BY: [Signature]  
 DRAWN BY: [Signature]  
 CHECKED BY: [Signature]

Rural Electrification Corporation Ltd.  
 Insulating Piercing Connector  
 for ABC to ABC Tee Joint

**ANNEXURE-J**

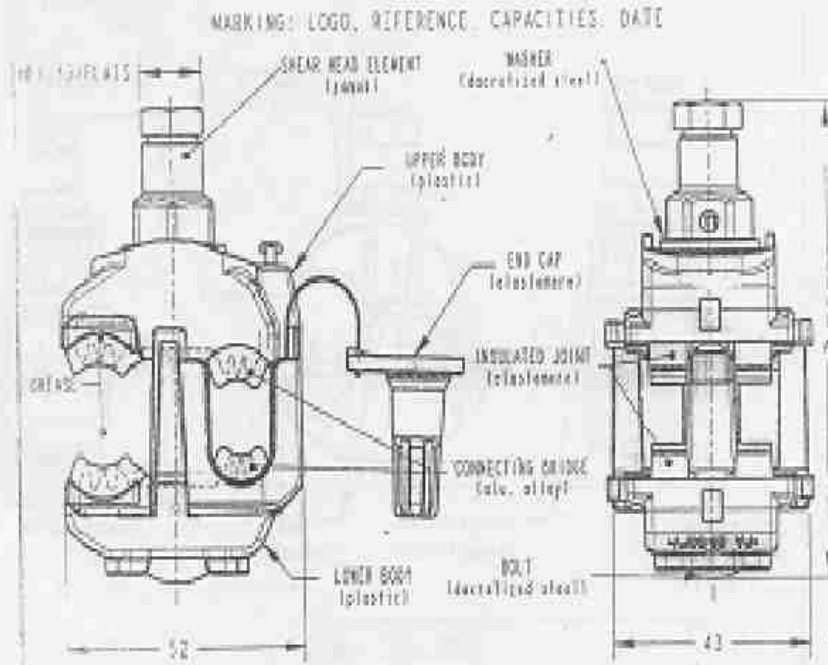

CAPACITIES: MAIN	CAPACITIES: TAP	WEIGHT	DIMENSION A	BREAKING SHEAR HEAD TORQUE
16 to 85mm <sup>2</sup>	4 to 35mm <sup>2</sup> - 150mm <sup>2</sup>	113.5g	88mm	11Nm

DESIGNED BY: DR. P. S. SINGH  
DESIGNED BY: DR. P. S. SINGH  
DESIGNED BY: DR. P. S. SINGH

**MATERIAL:** [Blank]

**Rural Electrification Corporation Ltd.**

**USE:** Insulating Pinning Connector for Distribution Line Charging

**ANNEXURE-K**

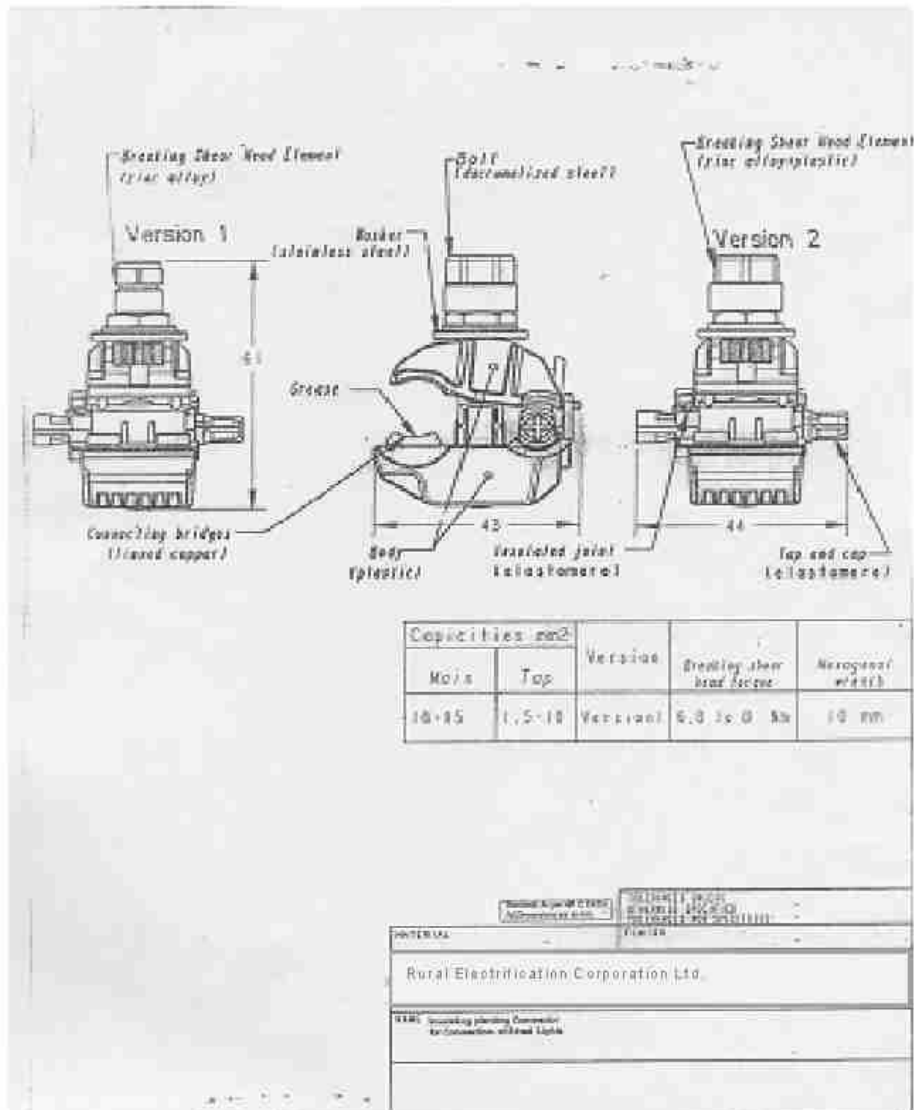

**28 11 kV and 33 kV Isolators**

**1) SCOPE**

This specification provides for design, manufacture, testing at manufactures works, delivery of outdoor station type 11KV and 33KV (Local) manual operating mechanism isolating without/ with earthing blades and complete in all respect with bi-metallic connectors. Operating mechanism, fixing details etc. shall be as described herein.

**2) PARTICULARS OF THE SYSTEM**

The isolators to be provided under this specification are intended to be used on 3 phase A.C. 50 cycles, effectively grounded system. The nominal system voltages are 11 kV & 33 kV respectively.

**3) STANDARD**

The Isolator shall comply in all respects with IS: 9921 or IEC Publication No.: 129. Equipment meeting any other authoritative standard which ensures an equal or better quality than the standard mentioned above will also be accepted.

**4) TYPE & RATING**

Isolators shall have three posts per phase, triple pole single throw, gang operated out-door type silver plated contacts with horizontal operating blade and isolators posts arranged vertically. The isolators will be double break type. Rotating blade feature with pressure relieving contacts is necessary i.e. the isolator shall be described in detail along-with the offer. However, the design of turn & twist arrangement shall be subject to owner’s approval. (Banging type feature is not acceptable). All isolators shall operate through 90 degree from their fully closed position to fully open position, so that the break is distinct and clearly visible from the ground level.

The equipment offered by the tenderer shall be designed for a normal current rating of 400 A for 11 KV & 630 A for 33 KV suitable for continuous service at the system voltage specified herein. The isolators are not required to operate under load but they must be called upon to handle magnetization currents of the power transformers and capacitive currents of bushings, bus-bars connections, very short lengths of cables and current of voltage transformers.

The rated insulation strength of the equipment shall not be lower than the levels specified in IS 9921 JEC publication No. 129, which are reproduced below

Standard declared voltage kv/rms	Rated voltage of the Isolator	Standard withstand positive kV (peak)	Impulse Voltage polarity	One minute power frequency withstand voltage KV (RMS)	
				Across the isolating distance	To earth and between poles
11 KV	12	85	75	45	35
33 KV	36	195	170	100	75

The 11 KV and 33 KV isolators are required with post insulators but with mounting structures. The isolators should be suitable for mounting on the Boards standard structures. The isolators shall be supplied with base channels along with fixing nuts, bolts and washers for mounting on the structured.

**5) TEMPRATURE RISE**

The maximum temperature attained by any part of the equipment when in service at site under continues full load conditions and exposed to the direct rays of Sun shall not exceed 45 degree centigrade above ambient temperature.

**6) ISOLATOR INSULATION**

Isolation to ground, insulation between open contacts and the insulation between phases of the completely assembled isolating switches shall be capable of withstanding the dielectric test voltage specified above.

**7) MAIN CONTACTS**

All isolators shall have heavy duty self aligning and high pressure line type fixed contacts of modern design and made of hard drawn electrolytic copper. The fixed contact should be of reverse loop type. The various parts shall be accordingly finished to ensure inter- changeability of similar components.

The fingers of fixed contacts shall be preferably in two pieces and each shall form the reverse loops to hold fixed contacts. The fixed contacts would be placed in 'c' clamp. The thickness of 'C' clamp shall be adequate. This channel shall be placed on a channel of adequate thickness. This channel shall be welded on an insulator mounting plate of 8mm thickness. The spring of fixed contact shall have housing to hold in place. This spring shall be made of stainless steel with adequate thickness. The pad for connection of terminal connector shall be of aluminum with thickness not less than 12 mm.

The switch blades forming the moving contacts shall be made from tubular section of hard drawn electrolytic copper having outer dia not less then 38 mm and thickness 3 mm. These contacts shall be liberally dimensioned so as to withstand safely the highest short circuit and over voltage that may be encountered during service. The surfaces of the contacts shall be rendered smooth and silver plated. The thickness of silver plating shall not be less than 15 microns for 11 KV and 25 microns for 33 KV. In nut shell, the male and female contact assemblies shall be of robust construction and design of these assemblies shall ensure the same.

1. Electro-dynamic withstands ability during short circuit without any risk of repulsion of contacts.
2. The current density in the copper parts shall not be less than 2 Amp/sq.mm and aluminium parts shall be less than 1 Amp/sq.mm.
3. Thermal withstand ability during short circuit.
4. Constant contact pressure even when the live parts of the insulator stacks are subjected to tensile stresses due to linear expansion of connected bus bar of flexible conductors either because of temperature verification or strong winds.
5. Wiping action during closing and opening.
6. Self alignment assuring closing of the switch without minute adjustment.

The earthing switch should be provided with three sets of suitable type of fixed contacts below the fixed contacts assemblies of the main switch on the incoming supply side and the sets of moving contacts having ganged operation. These contacts shall be fabricated out of electrolytic copper for 33 KV isolators with earth switch and designed to withstand current on the line.



Arcing contacts / Horn: Arcing contacts are not required.

Auxiliary switches : Auxiliary switches are not required.

**8) CONNECTORS**

The connectors for 11KV isolator shall be made of Aluminium alloy LM-9 or LM-25 and shall be suitable for Squirrel, Weasel and Rabbit ACSR Conductors for 11KV and Raccoon/Dog conductors for 33 KV with horizontal and vertical takeoff arrangement. The details in regard to dimensions, the number of bolts to be provided, material and manufacture shall be furnished by the bidder for owner approval before manufacturing. The groove provided in the connection should be able to accommodate conductor size mentioned above smoothly.

The clamps to be offered should be manufactured by gravity die-casting method only and not by sand casting process. It is necessary that suitable clamps are offered along with the isolator and also it is obligatory to give complete technical particular of clamps along with the drawing, as per details given above and also as per following detail.

1. The terminal connector shall be manufactured and tested as per IS: 5561.
2. All castings shall be free from blow holes, surface blisters, cracks and cavities.
3. All the sharp edges shall be blurred and rounded off.
4. No part of the clamp shall be less than 12 mm thick.
5. All current carrying parts shall be designed and manufactured to have minimum contact resistance.
6. Connectors shall be designed to be corona free in accordance with the requirement of IS: 5561.
7. All nuts and bolts shall be made of stainless steel only. Bimetallic sleeve/liner shall be 2 mm thick

Wherever necessary, bi-metallic strip of standard quality and adequate dimension shall be used.

**9) POST INSULATOR**

11KV / 33KV insulators shall be of reputed make subject to owner approval. The post insulators for the above 11 KV isolators shall comprise of three numbers 11 KV insulators per stack and 9 such stack shall be supplied with each isolator. Similarly, for 33 KV isolators, two numbers 33 KV insulators per stack and 9 stacks shall be supplied with each isolator. The insulator stack shall conform to the latest applicable Indian or IEC standard and in particulars to the IS; 2544 specification for porcelain post insulators. The porcelain used for manufactures of insulators shall be homogeneous, free from flaws or imperfections that might affect the mechanical or dielectric quality, and they shall be thoroughly vitrified, tough and impervious to moisture. The glazing of the porcelain shall be uniform brown colour, free from glisters, burns and other similar defects. Insulators of the same rating and type shall be interchangeable.

The porcelain and metal parts should be assembled in such a manner that any thermal expansion differential between the metal and the porcelain parts throughout the range of temperature variation shall not loosen the parts or create undue internal stresses which may affect the electrical or mechanical strength and rigidity. Each cap and base shall be of high-grade cast steel or malleable steel casting and they shall be machine faced and smoothly galvanised. The cap and base of the insulators shall be interchangeable with each other.

The tenders shall in variably enclose with the offer, the type test certificate and other relevant technical guaranteed particulars of insulators offered by them. Please note that isolators without type test certificates will not be accepted.

Each 11KV / 33KV Post Insulators used in the isolators should have technical particulars as detailed below:-

	<b>11KV</b>	<b>33KV</b>
1. Nominal system voltage KV (rms)	11	33
2. Highest system voltage KV (rms)	12	36
3. Dry P.F. One minute with stand KV (rms)	35	75
4. Wet PF one minute withstand KV (rms)	35	75
5. P.F. Puncture withstand test voltage KV	1.3 time the actual dry flash over voltage of the unit	
6. Impulse voltage withstand test KV (peak)	75	170
7. Visible discharge test KV voltage	9	27
8. Creepage distance mm (min)	320	580
9. Tensile strength in KN	10KN	16KN
10. Short time current rating for 3 Secs	25KA	25KA

For 33 KV Isolators: In place of 33 KV Post Insulator the composition of 2 units of 22KV Post Insulators per stack complying the following parameters are acceptable:-

(a) Norminal system voltage	:	33 KV
(b) Highest system voltage	:	36 KV
(c) Impulse voltage withstand	:	170 KV
(d) Power frequency wet withstand voltage	:	75 KV
(e) Height of stack	:	500 mm
(f) Creepage distance (Minimum)	:	840 mm
(g) Tensile Strength	:	30KN
(h) Bending strength	:	4.5KN

**Operating Mechanism for 11KV / 33KV Isolators:-**

All Isolators and earthing switches shall have separate dependent manual operation. The Isolator should be provided with padlocking arrangements for locking in both end position to avoid unintentional operation. For this purpose Godrej make 5 lever brass padlocks having high neck with three keys shall be provided. The isolating distances should be visible for isolators.

The Isolators and Isolators with earth switch inclusive of their operating mechanism should be such that they cannot come out of their open or close position by gravity wind pressure, vibrations reasonable shocks or accidental touching of connecting rods of the operating mechanism. Isolators should be capable of resisting in closed position, the dynamic and thermal effects of maximum possible short circuit current at the installation point. They shall be so constructed that they do not open under the influence of the short circuit current. The operating mechanism should be of robust construction and easy to operate by a single person and conveniently located for local operation in the switchyard. Provision for earthing of operating handle by means of 8 SWG GS wire must be made.

**10) PIPES**

Tandem pipes operating handle shall be class B ISI marked type having atleast 24mm internal diameter for 11KV/33KV isolator. The operating pipe shall also be class B ISI marked with internal diameter of atleast 32 mm and 38 mm for 11 KV and 33KV isolators respectively.

The pipe shall be terminated in to suitable universal type joints between the insulator bottom bearing and operating mechanism.

**11) BASE CHANNEL**

The Isolator shall be mounted on base fabricated from steel channel section of adequate size not less than 75x40x6 mm for 11KV and 100x50x6 mm for 33KV.

To withstand total weight of isolator and insulator and also all the forces that may encounter by the isolator during services, suitable holes shall be provided on this base channel to facilitates it's mounting on our standard structures. The steel channel in each phase shall be mounted in vertical position and over it two mounting plates atleast 8mm thick with suitable nuts and bolts shall be provided for minor adjustment at site.

**12) CLEARANCES**

We have adopted the following minimum clearance for isolators in our system .The bidder should therefore keep the same in view while submitting their offers: -

Description	Center distance between Poles (Center to Center) i.e. Phase to Phase clearance	Distance between center lines of outer posts on same pole
11 KV Isolator	75 Cm	60 Cm
33 KV Isolator	120 Cm	96 Cm

**29 11kV and 33 kV Air Break Switches**

**1) SCOPE**

This specification provides for manufacture, testing at works and supply of 11KV & 33KV AB switches. The 11KV and 33 KV AB switches shall conform to IS: 9920 (Part-I to IV)

**2) AB SWITCHES**

The 11KV & 33KV Air Break Switches are required with two poles in each phase. The AB Switches shall be supplied complete with phase coupling shaft, operating rod and operating handle. It shall be manually gang operated and vertically break and horizontal mounting type.

**The equipment offered by the bidder shall be designed for a normal current rating of 200 Amps and for continuous service at the system voltage specified as under:**

- i) 11 KV AB Switch : 11KV + 10% continuous 50 C/s solidly grounded earthed neutral system
- ii) 33KV AB Switch : 33 kV + 10% -do-

The length of break in the air shall not be less than 400 mm for 11KV AB Switches and 500 mm for 33 KV AB Switches.

The 11KV & 33KV AB Switches are required with post insulators. The AB switches should be suitable for mounting on the structure. The mounting structure will be arranged by the bidder. However, the AB Switches shall be supplied with base channel for mounting on the structure which will be provided by the owner. The phase to phase spacing shall be 750mm in case of 11KV AB Switches & 1200mm in case of 33KV AB Switches.

**3) POST INSULATORS**

The complete set of three phase AB Switches shall have stacks of post insulators.

11KV AB Switches: 3 No. 11KV Post Insulator per stack

33KV AB Switches: 3 No. 33KV Post Insulator per stack

The post insulators should conform to the latest applicable Indian standards IS: 2544 Specification for Porcelain Post insulator of compact solid core or long rod insulators are also acceptable. Creepage distance should be adequate for highly polluted outdoor atmosphere in open atmosphere. The porcelain used for manufacture of AB Switches should be homogeneous free from flaws or imperfections that might affect the mechanical dielectric quality. They shall be thoroughly vitrified, tough and impervious to moisture. The glazing of the porcelain shall be of uniform brown in colour, free from blisters, burns and other similar defects. Insulators of the same rating and type shall be interchangeable.

The porcelain and metal parts shall be assembled in such a manner that any thermal expansion differential between the metal and porcelain parts through the range of temperature variation shall not loose the parts or create undue internal stresses which may affect the electrical or mechanical strength. Cap and base of the insulators shall be interchangeable with each other. The cap and base shall be properly cemented with insulators to give perfect grip. Excess cementing must be avoided.

Each 11KV & 33KV Post Insulators should have technical particulars as detailed below:

		11 kV	33 kV
i	Nominal system voltage kV (rms)	11	33
ii	Highest system voltage kV (rms.)	12	36
iii	Dry Power Frequency one kV minute withstand voltage (rms) in KV	35	75
iv	Wet Power frequency one minute withstand voltage (rms) in KV	35	75
v	Power Frequency puncture kV (rms) voltage	1.3 times the actual dry flashover voltage	
vi	Impulse withstand voltage kV (Peak)	75	170
vii	Visible discharge voltage kV (rms)	9	27
viii	Creepage distance in mm (minimum)	320	580

The rated insulation level of the AB Switches shall not be lower than the values specified below:-

Sl. No	Standard declared voltage KV/RMS	Rated Voltage of the AB Switches	Standard impulse with stand voltage (positive & negative polarity kV (Peak)		One Minute power frequency withstand voltage kV (rms)	
			Across the Isolating distance	To earth & between poles	Across the Isolating distance	To earth & between poles
i	11KV	12KV	85KV	75KV	32KV	28KV
ii	33KV	36KV	195KV	170KV	80KV	70KV

#### 4) TEMPERATURE RISE

The maximum temperature attained by any part of the equipment when in service at site under continuous full load conditions and exposed to the direct rays of Sun shall not exceed 45 degree above ambient.

**5) MAIN CONTACTS**

AB Switches shall have heavy duty self-aligning type contacts made of hard drawn electrolytic copper/brass. The various parts should be accordingly finished to ensure interchangeability of similar components. The moving contacts of the switch shall be made from hard drawn electrolytic copper brass. This contact shall have dimensions as per drawing attached so as to withstand safely the highest short-circuit currents and over voltage that may be encountered during service. The surface of the contact shall be rounded smooth and silver-plated. In nut shell the male and female contact assemblies shall ensure.

1. Electro-dynamic withstands ability during short circuits without any risk of repulsion of contacts.
2. Thermal withstands ability during short circuits.
3. Constant contact pressure even when the lower parts of the insulator stacks are subjected to tensile stresses due to linear expansion of connected bus bar of flexible conductors either because of temperature variations or strong winds.
4. Wiping action during closing and opening.
5. Fault alignment assuring closing of the switch without minute adjustments.

**6) CONNECTORS**

The connectors shall be made of hard drawn electrolytic copper or brass suitable for Raccoon/Dog ACSR conductor for both 11KV & 33KV AB Switches. The connector should be 4 -bolt type.

**7) OPERATING MECHANISM**

All AB Switches shall have separate independent manual operation. They should be provided with ON/OFF indicators and padlocking arrangements for locking in both the end positions to avoid unintentional operation. The isolating distances should also be visible for the AB Switches.

The AB Switch will be supplied with following accessories:

SI	Item	Size of 11KV AB Switch	Size of 33KV AB Switch
i	Operating Rod (GI dia) ISI mark	Length 5.50 meter dia: 25MM	Length 5.50 mtrs dia: 40MM
ii	Phase coupling square rod (GI) ISI mark	Length 1800 mm Size 25x25 mm	Length 2700 mm Size 40 x 40 mm
iii	Hot dip galvanized Operating handle (GI)	1 No.	1 No.

The AB Switches shall be capable to resist any chance of opening out when in closed position. The operating Mechanism should be of robust constructions, easy to operate by single person and to be located conveniently for local operation in the switchyard. The GI pipe shall conform to('B' class or Medium class Blue strip) ISS: 1239-68 and ISI marked by embossing. The vertical down rod should be provided with

adequate joint in the mid section to avoid bending or buckling. Additional leverage should be provided to maintain mechanical force with minimum efforts.

All iron parts should be hot dip galvanized as per IS 4759-1979 and zinc coating shall not be less than 610 gm/sq. meter. All brass parts should be silver plated and all nuts and bolts should be hot dip galvanized.

**8) ARCING HORNS**

It shall be simple and replaceable type. They should be capable of interrupting line-charging current. They shall be of first make and after break type.

**9) BUSH**

The design and construction of bush shall embody all the features required to withstand climatic conditions specified so as to ensure dependable and effective operations specified even after long periods of inaction of these Air Break Switches. They shall be made from highly polished Bronze metal with adequate provision for periodic lubrication through nipples and vent.

**10) DESIGN, MATERIALS AND WORKMANSHIP**

All materials used in the construction of the equipment shall be of the appropriate class, well finished and of approved design and material. All similar parts should be accurately finished and interchangeable.

Special attention shall be paid to tropical treatment to all the equipment, as it will be subjected during service to extremely severe exposure to atmospheric moisture and to long period of high ambient temperature. All current carrying parts shall be of non-ferrous metal or alloys and shall be designed to limit sharp points/edges and similar sharp faces.

The firm should have the following type test certificate. The type test should be from CPRI or equivalent lab:-

1. Test to prove capability of rated peak short circuit current and the rated short time current. The rated short time current should correspond to minimum of 10K Amp and the peak short circuit current should correspond to minimum of 25K Amps.
2. Lightning impulse voltage test with positive & negative polarity.
3. Power Frequency voltage dry test and wet test
4. Temperature rise test
5. Mill volt drop tests

The above tests should be performed on the AB Switches, manufactured as per owner approved drawing with the specification. Along with the type test certificate, the certified copy of the drawing (from the testing lab) should also be kept for inspection of our officer. Also the test certificates should not be older than 5 years from the date of opening of tender.

Dimension of 11 & 33KV AB Switches in (Max.)Tolerance 5%.

Sl.	Particulars	11KV AB Switch	33KV AB Switch
i	MS Channel	450x75x40	675x100x50
ii	Creepage distance of Post Insulator	320mm (Min)	580mm (Min)
iii	Highest of Port shell	254 mm	368 mm
iv	Fixed contact assembly		
	i) Base	165x36x8	165x36x8
	Ii) Contact	70x30x6	70x30x6
	Iii) GI cover	110x44	140x44
	v) Spring	6 Nos.	6 Nos.

**11) Moving Contact Assembly**

i	Base Assembly	135x25x8	170x40x8
ii	Moving	180x25x9	290x25x14
iii	Bush	Bronze Metal	Bronze Metal
iv	Thickness of Grooves	7	11

**12) Connectors**

i	Connector	60x50x8 (Moving & fix both)	60x50x8 (Moving & fix both)
---	-----------	-----------------------------	-----------------------------

The bidder should provide AB Switches with terminal connectors, set of insulators, mechanical inter works and arcing horns sets. The base channel for the mounting of AB Switches shall also be included in the scope of AB Switches. The operating mechanisms together with down pipe operating handle etc. are also included in the scope of supply.





**10.1** The cutouts shall be of single vent type (downward) having a front connected fuse carrier suitable for angle mounting.

**10.2** All ferrous parts shall be hot dip galvanised in accordance with the latest version of IS:2633. Nuts and bolts shall conform to IS:1364. Spring washers shall be electro-galvanised.

**10.3** Typical constructional details of the fuse cutout are shown in Fig. 1

**11. FUSE BASE TOP ASSEMBLY**

**11.1** The top current carrying parts shall be made of a highly conductive copper alloy and the contact portion shall be silver plated for corrosion resistance and efficient current flow. The contact shall have a socket cavity for latching and holding firmly the fuse carrier until the fault interruption is completed within the fuse.

**11.2** The top contact shall be actuated by a strong steel spring which keeps it under sufficient pressure to maintain a firm contact with the fuse carrier during all operating conditions. The spring shall also provide flexibility and absorbs most of the stresses when the fuse carrier is pushed into the closing position.

**11.3** The current carrying parts of the assembly shall be protected from water and dust formation by a stainless steel top cover.

**11.4** The top contact assembly shall have a robust galvanised steel hook to align and guide the fuse carrier into the socket latch even when the fuse carrier is closed at an off-centre angle.

**11.5** The top assembly shall have an aluminum alloy terminal connector (refer clause 19).

**11.6** The top assembly shall be robust enough to absorb bulk of the forces during the fuse carrier closing and opening operations and shall not over-stress the spring contact. It shall also prohibit accidental opening of the fuse carrier due to vibrations or impact.

**12. FUSE BASE BOTTOM ASSEMBLY**

**12.1** The conducting parts shall be made of high strength highly conductive copper alloy and the contact portion shall be silver plated for corrosion resistance and shall provide a low resistance current path from the bottom fuse carrier contacts to the bottom terminal connector.

**12.2** The bottom assembly shall have hinge contacts made from highly conductive, anti-corrosive copper alloy and shall accommodate and make a firm contact with the fuse carrier bottom assembly. The fuse carrier shall be placed easily in or lifted from The hinges without any maneuvering. In addition, the bottom assembly shall perform the following functions :-

- i) When opened manually or after fault interruption the fuse carrier shall swing through 180° to the vertical and its further travel shall be prevented by the fuse base bottom assembly.
- ii) The fuse carrier shall be prevented from slipping out of the self locking hinges during all operating conditions and only when the fuse carrier has reached its fully open position can it be removed from the hinge support.

**12.3** The assembly shall have an aluminium alloy terminal connector (refer clause 19).

**13. FUSE CARRIER TOP ASSEMBLY**

- 13.1** The fuse carrier top contact shall have a solid replaceable cap made from highly conductive, anti-corrosive copper alloy and the contact portion shall be silver plated to provide a low resistance current path from the Fuse Base Top Contact to the Fuse Link. It shall make a firm contact with the button head of the fuse link and shall provide a protective enclosure to the fuse link to check spreading of arc during fault interruptions.
- 13.2** The fuse carrier shall be provided with a cast bronze opening eye (pull ring) suitable for operation with a hook stick from the ground level to pull-out or close-in the fuse carrier by manual operation.

**14. FUSE CARRIER BOTTOM ASSEMBLY**

- 14.1** The fuse carrier bottom assembly shall be made of bronze castings with silver plating at the contact points to efficiently transfer current to fuse base. It shall make smooth contact with the fuse base bottom assembly during closing operation.
- 14.2** The bottom assembly shall have a lifting eye for the hook stick for removing or replacing the fuse carrier.
- 14.3** The bottom assembly shall have a suitable ejector which shall perform the following functions :
- i) It shall keep the fuse link in the centre of fuse tube and keep it tensioned under all operating conditions.
  - ii) It shall be capable of absorbing the shock when the fuse carrier is pushed into the closed position and shall not allow the fuse link to be damaged. This is specially important when the fuse link is of low-ampere rating.
  - iii) The ejector at the instant of interruption shall retain the fuse carrier in the closed position long enough to ensure that the arc is extinguished within the fuse tube thereby excluding the possibility of arcing and subsequent damage at the contact surfaces.
  - iv) The ejector shall help the fuse link separation after fault interruption, allowing the fuse carrier to drop out and clearing the pigtail of the blown fuse link through the bore of fuse tube.

**15. FUSE BASE (PORCELAIN)**

The fuse base shall be a bird-proof, single unit porcelain insulator with a creepage distance (to earth) not less than 320mm. The top and bottom assemblies as also the middle clamping hardware shall be either embedded in the porcelain insulator with sulphur cement or suitably clamped in position. For embedded components, the pull out strength should be such as to result in breaking of the porcelain before pull out occurs in a test. For porcelain insulators, the beam strength shall not be less than 1000 Kg.

**16. FUSE TUBE**

The fuse tube shall be made of fibre glass coated with ultraviolet inhibitor on the outer surface and having arc quenching bone fibre liner inside. The tube shall have high bursting strength to sustain high pressure of the gases during fault interruption. The inside diameter of the fuse tube shall be 17.5mm. The

solid cap of the fuse carrier shall clamp the button head of the fuse link, closing the top end of the fuse tube and allowing only the downward venting during fault interruption.

**17. TYPE TESTS**

The cutout shall be subjected to the following type tests :

i) Dielectric tests (rated impulse withstands and rated one minute power frequency with stand test voltages)

ii) Temperature rise test

The above tests shall be carried out in accordance with IS:9385 Part I & II.

**For Porcelain Fuse Base only.**

iii) Pull out test for embedded components of the fuse base

iv) Beam strength of porcelain base

**18. MOUNTING ARRANGEMENT**

**18.1** The cutouts shall be provided with a suitable arrangement for mounting these on 75x40mm or 100x50mm channel cross arm in such a way that the centre line of the fuse base is at an angle of 15° to 20° from the vertical and shall provide the necessary clearances from the support. Mounting arrangement shall be made of high strength galvanised steel flat and shall be robust enough to sustain the various stresses encountered during all operating conditions of the cutout. For more details see enclosed figure 2.

**18.2** Strength of the component marked 1 (see figure) shall be determined by clamping the member with the shorter leg at the top to a rigid support by M-10 carriage bolts. A downward force shall be applied along the axis of M-14 carriage bolt parallel to the longer leg and in the direction of longer leg of the member under test. A load of 50 Kg. shall be applied and then removed to take up any slack in the mounting arrangement before the measurement of position is taken, the permanent set measured at the axis of the M-14 carriage bolt shall not exceed 1.6mm when a load of 425 Kg. is applied and removed.

**18.3** The strength of the M-14 bolt shall in no case be less than 1900 Kg. and the strength of M-10 bolts not less than 3500 Kg.

**19. TERMINAL CONNECTIONS**

The cut-out shall be provided with two aluminium alloy (alloy designation 2280 (A-11) as per IS:617-1975) terminal connectors at top and bottom of fuse base assemblies to receive aluminium conductors of diameters between 6.3mm to 10.05mm. These terminals shall be easily accessible irrespective of the cut-out location with respect to the pole. The terminals shall meet the test requirements of REC Construction Standard.

**20. INSPECTION**

All tests and inspection shall be made at the place of manufacture unless otherwise especially agreed upon by the manufacturer and the purchaser at the time to purchase. The manufacturer shall afford the inspector representing the purchaser all reasonable facilities without charge, to satisfy him that the material is being furnished in accordance with this specification.

The purchaser has the right to have the tests carried out at his own cost by an independent agency whenever there is dispute regarding the quality of supply.

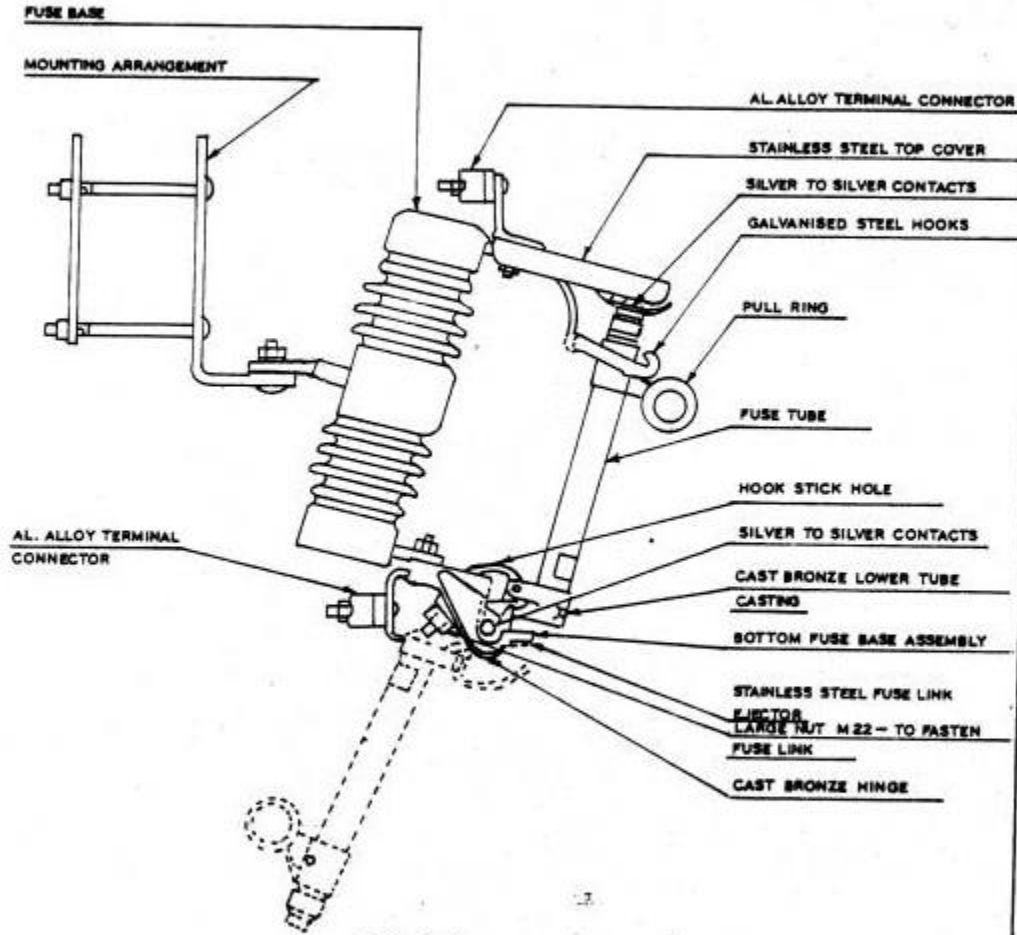
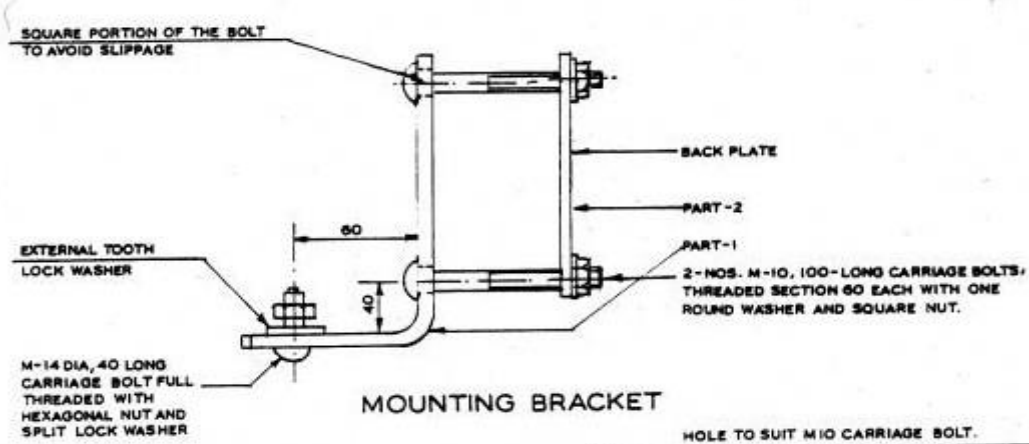

FIG. :- 1

११ के. वी. फ्यूज कट-आउट का प्रारूपिक निर्माण विवरण

TYPICAL CONSTRUCTIONAL DETAILS OF 11KV  
 FUSE CUT-OUT



**MOUNTING BRACKET**

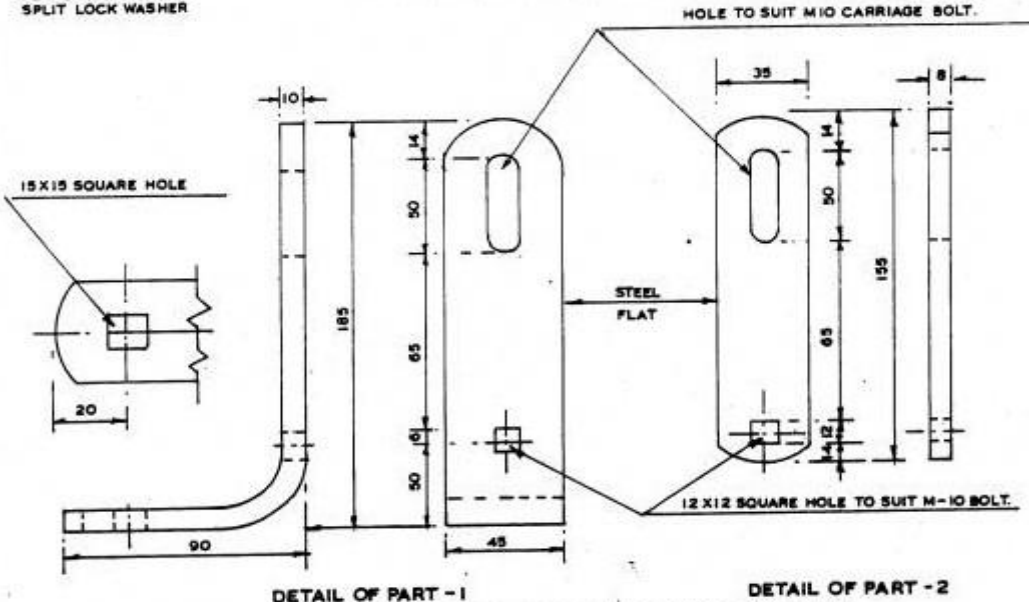

**FIG.2:- MOUNTING DETAILS OF 11KV FUSE CUTOUT**

ALL DIMENSIONS ARE IN MM.

११ के. वी. ड्रॉप-आउट फ्यूज कटआउट 11KV DROP-OUT FUSE CUTOUT	
SCALE :- N.T.S	JULY, 1987

**31 33& 11 kV Station Class Lightning Arrestor & 11 kV Distribution Class Surge Arrestors**

**1. 33kV VOLTAGE CLASS SURGE ARRESTORS**

Lightning Arrestors at Grid Substation shall be of Station class only in 33 & 11 KV System.

**1.1. INTRODUCTION**

The section covers the specification of 33kV voltage level, 10 kA, and Station class heavy duty, gapless metal (zinc) oxide Surge Arrestors complete with insulating base, terminal clamps, complete fittings & accessories for installation on outdoor type 33kV switchgear/transmission lines / transformers.

**1.2. STANDARDS**

The design, manufacture and performance of Surge Arrestors shall comply with IS: 3070 Part-3 and other specific requirements stipulated in the specification. Unless otherwise specified, the equipment, material and processes shall conform to the latest applicable Indian/International Standards as listed hereunder:

IS:2071-1993 (Part-1)	Methods of High Voltage Testing General Definitions & Test Requirements.
IS:2071-1974(Part-2)	Test Procedures
IS:2629-1985	Recommended Practice for hot dip galvanizing on Iron & Steel
IS:2633-1986	Method for Testing uniformity of coating of zinc coated Articles.
IS:3070-1993 (Part – 3)	Specification for surge arrestor for alternating current systems. Metal-Oxide lightning Arrestors without gaps
IS:4759-1996	Specification for hot dip zinc coating on Structural Steel and Other allied products.
IS:5621-1980	Hollow Insulators for use in Electrical Equipment.
IS:6209-1982	Methods of Partial discharge measurement.
IS:6745	Method for determination of mass of zinc coating on zinc coated iron and steel articles
ANSI/IEEE-C.62.11	Metal oxide, Surge Arrestor for AC Power Circuits.
IEC –60099-4	Surge Arrestors

The equipment complying with any other internationally accepted standards shall also be considered if it ensures performance equivalent to or superior to the Indian Standards.

**1.3. GENERAL REQUIREMENT**

**1.3.1.** The metal oxide gap less Surge Arrestor without any series or shunt gap shall be suitable for protection of 33kV switchgear, transformers, associated equipment and 33 kV lines from voltage surges resulting from natural disturbance like lightning as well as system disturbances.

**1.3.2.** The surge arrestor shall draw negligible current at operating voltage and at the same time offer least resistance during the flow of surge current.

**1.3.3.** The surge arrestor shall consist of non-linear resistor elements placed in series and housed in electrical grade porcelain housing / silicon polymeric of specified creepage distance.

**1.3.4.** The assembly shall be hermetically sealed with suitable rubber gaskets with effective sealing system arrangement to prevent ingress of moisture.

- 1.3.5.** The surge arrester shall be provided with line and earth terminals of suitable size. The ground side terminal of surge arrester shall be connected with 25x6 mm galvanized strip, one end connected to the surge arrester and second end to a separate ground electrode. The bidder shall also recommend the procedure which shall be followed in providing the earthing system to the Surge Arrester.
- 1.3.6.** The surge arrester shall not operate under power frequency and temporary over voltage conditions but under surge conditions, the surge arrester shall change over to the conducting mode.
- 1.3.7.** The surge arrester shall be suitable for circuit breaker performing 0-0.3sec.-CO-3 min-CO- duty in the system.
- 1.3.8.** Surge arrestors shall have a suitable pressure relief system to avoid damage to the porcelain/silicon polymeric housing and providing path for flow of rated fault currents in the event of arrester failure.
- 1.3.9.** The reference current of the arrester shall be high enough to eliminate the influence of grading and stray capacitance on the measured reference voltage.
- 1.3.10.** The arrestors for 33 kV system shall be suitable for mounting on transformers, Bus, Line & structure as per scheme. The supplier shall furnish the drawing indicating the dimensions, weights etc. of the surge arrestors for the design of mounting Structure.
- 1.3.11.** The arrester shall be capable of handling terminal energy for high surges, external pollution and transient over voltage and have low losses at operating voltages.

**1.4. ARRESTOR HOUSING**

- 1.4.1.** The arrester housing shall be made up of porcelain/**silicon polymeric** housing and shall be homogenous, free from laminations, cavities and other flaws of imperfections that might affect the mechanical and dielectric quality. The housing shall be of uniform brown (**for porcelain**)/Grey (**for silicon polymeric**) colour, free from blisters, burrs and other similar defects.

Arrestors shall be complete with fasteners for stacking units together and terminal connectors.

- 1.4.2.** The housing shall be so coordinated that external flashover shall not occur due to application of any impulse or switching surge voltage up to the maximum design value for arrester. The arrestors shall not fail due to contamination. The 33 kV arrestors housing shall be designed for pressure relief class as given in Technical Parameters of the specification.
- 1.4.3.** Sealed housings shall exhibit no measurable leakage.

**1.5. FITTINGS & ACCESSORIES**

- 1.5.1.** The surge arrester shall be complete with fasteners for stacking units together and terminal connectors.
- 1.5.2.** The terminals shall be non-magnetic, corrosion proof, robust and of adequate size and shall be so located that incoming and outgoing connections are made with minimum possible bends. The top metal cap and base of surge arrester shall be galvanized. The line terminal shall have a built in clamping device which can be adjusted for both horizontal and vertical take off.

**1.6. TESTS**



**1.6.1. Test on Surge Arrestors**

The Surge Arrestors offered shall be type tested and shall be subjected to routine and acceptance tests in accordance with IS : 3070 (Part-3)/IEC-60099-4. In addition, the suitability of the surge arresters shall also be established for the followings

- i) **Acceptance tests**
  - a) Measurement of power frequency reference voltage of arrester units.
  - b) Lightning impulse residual voltage on arrester units (IEC clause 6.3.2)
  - c) Internal ionization or partial discharge test
  
- ii) **Special Acceptance tests**
  - a) Thermal stability test (IEC ~~99-4~~ clause 7.2.2)
  - b) Watt loss test.
  
- iii) **Routine tests**
  - a) Measurement of reference voltage
  - b) Residual voltage test of arrester unit
  - c) Internal ionization or partial discharge test
  - d) Sealing test
  - e) Verticality check on completely assembled surge arresters as a sample test on each lot if applicable.
  
- iv) **Type Tests**

Following shall be type test as per IS 3070 (Part 3): 1993 or its latest amendment.

1.	Insulation Withstand test a) Lightning Impulse b) Power Frequency (Dry/Wet)
	Residual Voltage Test a) Steep current impulse residual voltage test b) Lightning impulse residual voltage test c) Switching Impulse Residual voltage test
	Long duration current impulse withstand test
	Switching surge operating duty test
	Power frequency voltage Vs. Time characteristics
	Accelerated Ageing test

	Pressure relief test  a) High Current b) Low Current
	Artificial pollution test (for porcelain housing)
	Seismic Test
	Partial Discharge test
	Bending test
	a) Temperature cycle test (for porcelain housing) b) Porosity test (for porcelain housing)
	Galvanising test on metal parts
	Seal Leakage test (for porcelain housing)
	Seal leak test and operation tests ( for surge monitor)
	Weather ageing test (for polymer housing)

**1.6.2.** The maximum residual voltages corresponding to nominal discharge current of 10 kA for steep current, impulse residual voltage test, lightning impulse protection level and switching impulse level shall generally conform to **Annex-K of IEC-99-4**.

**1.6.3.** The contractor shall furnish the copies of the type tests and the characteristics curves between the residual voltage and nominal discharge current of the offered surge arrester and power frequency voltage v/s time characteristic of the surge arrester subsequent to impulse energy consumption as per clause 6.6.7 of IS:3070 (Part-3) offered along with the GTP/Drawing.

**1.6.4.** The surge arrester housing shall also be type tested and shall be subjected to routine and acceptance tests in accordance with IS: 5621.

**1.6.5. Galvanization Test**

All Ferrous parts exposed to atmospheric condition shall have passed the type tests and be subjected to routine and acceptance tests in accordance with IS:2633 & IS 6745.

**1.7. NAME PLATE**

**1.7.1.** The name plate attached to the arrester shall carry the following information:

- Rated Voltage
- Continuous Operation Voltage
- Normal discharge current
- Pressure relief rated current
- Manufacturers Trade Mark
- Name of Sub-station
- Year of Manufacturer
- Name of the manufacture
- Name of Client-'' ''
- Purchase Order Number along with date

**1.8. DRAWINGS AND INSTRUCTION MANUALS**

Within 15 days of receipt of the order, the successful tenderer shall furnish to the purchaser the following drawings and literature for approval:

- (i) Outline dimensional drawings of Surge Arrester and all accessories.
- (ii) Assembly drawings and weights of main component parts.
- (iii) Drawings of terminal clamps.
- (iv) Arrangement of earthing lead.
- (v) Minimum air clearance to be maintained of line components to ground.
- (vi) Name plate
- (vii) Instructions manual
- (viii) Drawing showing details of pressure relief valve
- (ix) Volt-time characteristics of surge arrestors
- (x) Detailed dimensional drawing of porcelain housing/Silicon polymeric i.e. internal diameter, external diameter, thickness, height, profile, creepage distance, dry arcing distance etc.

**1.9. TECHNICAL PARTICULARS**

**1.9.1.** The surge arrestors shall conform to the following standard technical requirements. The Insulation values shall be enhanced considering the altitude of operation & other atmospheric conditions.

**System Parameters:**

Nominal system voltage	:	33 kV
Highest system voltage	:	36 kV
System earthing	:	Solidly earthed system
Frequency (Hz)	:	50
Lightning Impulse withstand Voltage (kVP)	:	170

Power frequency withstand Voltage (kV rms)	:	70
Connection to system	:	Phase to earth

**1.9.2. Surge Arrestors**

Type of Surge Arrestor	:	Gapless Metal oxide outdoor
Arrestor rating (kV rms)	:	30
Continuous Operating voltage (kV rms)	:	25
Standard Nominal Discharge Current Rating (kA) (8x20 micro impulse shape)	:	10
Line discharge class	:	2
Degree of protection	:	<b>IP-67</b>
Lightning Impulse at 10 kA	:	85
Partial discharge at 1.05 COV not greater than	:	50 (PC)
Energy capability corresponding to		
a) Arrestor rating (kJ/kV)	:	4.5
b) COV (kJ/kV)	:	4.9
Peak current for high current impulse operating duty of arrestor classification 10 kA	:	100

**1.9.3. Insulator Housing**

Power frequency withstand test voltage (wet) (kV rms)	:	70
Lightning impulse withstand/tests voltage (kVP)	:	170
Pressure Relief Class	:	40
Creepage distance not less than	:	900 mm

**1.9.4. Galvanisation**

<u>Fabricated Steel Articles</u>		
-- 5 mm thick cover	:	610 g/m <sup>2</sup>
-- Under 5 mm but not less than 2 mm thickness	:	460 g/m <sup>2</sup>
-- Under 2 mm but not less than 1.2 mm thickness	:	340 g/m <sup>2</sup>
<u>Castings</u>		
-- Grey Iron, malleable iron	:	610 g/m <sup>2</sup>
<u>Threaded works other than tubes &amp; tube fittings</u>		
-- Under 10 mm dia		270 g/m <sup>2</sup>
-- 10 mm dia & above		300 m <sup>2</sup>

**2. 11kV VOLTAGE CLASS SURGE ARRESTORS**

**2.1. INTRODUCTION**

This section covers the specification of 11kV voltage station Surge Arrestors for installation on outdoor type 11kV switchgear, transmission lines, transformers etc. 11kV side of which is not enclosed in a cable box. Station class surge arrestors shall be complete with fasteners for stacking units.

**2.2. STANDARDS**

The design, manufacture and performance of Surge Arrestors shall comply with IS: 3070 Part-3 and other specific requirements stipulated in the specification. Unless otherwise specified, the equipment, material & processes shall conform to the latest amendments of the following:

IS:2071-1993 (Part-1)	Methods of High Voltage Testing General Definitions & Test Requirements.
IS:2071-1974 (Part-2)	Test Procedures.
IS: 2629-1985	Recommended Practice for hot dip galvanizing on Iron & Steel.
IS: 2633-1986	Method for Testing uniformity of coating of zinc coated Articles.
IS:3070-1993 (Part – 3)	Specification for surge arrestor for alternating current systems. Metal-Oxide lightning Arrestors without gaps.
IS: 4759-1996	Specification for hot dip zinc coating on structural steel and other allied products.
IS: 5621-1980	Hollow Insulators for use in Electrical Equipment.
IS: 6209-1982	Methods of Partial discharge measurement.
IS: 6745	Method for determination of mass of zinc coating on zinc coated iron and steel articles.
ANSI/IEEE-C.62.11	Metal oxide, Surge Arrestor for AC Power Circuits.
IEC –60099-4	Surge Arrestors.

The equipment complying with any other internationally accepted standards shall also be considered if it ensures performance equivalent to or superior to the Indian Standards.

**2.3. GENERAL REQUIREMENT**

- 2.3.1.** The metal oxide gap less Surge Arrestor without any series or shunt gap shall be suitable for protection of 11 kV side of power transformers, associated equipment and 11kV lines from voltage surges resulting from natural disturbance like lightning as well as system disturbances.
- 2.3.2.** The surge arrestor shall draw negligible current at operating voltage and at the same time offer least resistance during the flow of surge current.
- 2.3.3.** The surge arrestor shall consist of non-linear resistor elements placed in series and housed in electrical grade porcelain housing / silicon polymeric of specified Creepage distance.
- 2.3.4.** The assembly shall be hermetically sealed with suitable rubber gaskets with effective sealing system arrangement to prevent ingress of moisture.

- 2.3.5.** The surge arrester shall be provided with line and earth terminals of suitable size. The ground side terminal of surge arrester shall be connected with 25x6 mm galvanized strip, one end connected to the surge arrester and second end to a separate ground electrode. The bidder shall also recommend the procedure which shall be followed in providing the earthing system to the Surge Arrester.
- 2.3.6.** The surge arrester shall not operate under power frequency and temporary over voltage conditions but under surge conditions, the surge arrester shall change over to the conducting mode.
- 2.3.7.** The surge arrester shall be suitable for circuit breaker performing 0-0.3 min-CO-3 min-CO- duty in the system.
- 2.3.8.** Surge arrestors shall have a suitable pressure relief system to avoid damage to the porcelain/ silicon polymeric housing and providing path for flow of rated fault currents in the event of arrester failure.
- 2.3.9.** The reference current of the arrester shall be high enough to eliminate the influence of grading and stray capacitance on the measured reference voltage.
- 2.3.10.** The Surge Arrester shall be thermally stable and the bidder shall furnish a copy of thermal stability test with the bid.
- 2.3.11.** The arrester shall be capable of handling terminal energy for high surges, external pollution and transient over voltage and have low losses at operating voltages.
- 2.3.12.** The surge arrester shall be provided with line and earth terminals of suitable size.

**2.4. ARRESTOR HOUSING**

- 2.4.1.** The arrester housing shall be made up of porcelain/**silicon polymeric** housing and shall be homogenous, free from laminations, cavities and other flaws of imperfections that might affect the mechanical and dielectric quality. The housing shall be of uniform **brown (for porcelain)/Grey (for silicon polymeric)** colour, free from blisters, burrs and other similar defects.

Arrestors shall be complete with fasteners for stacking units together and terminal connectors.

- 2.4.2.** The housing shall be so coordinated that external flashover shall not occur due to application of any impulse or switching surge voltage upto the maximum design value for arrester. The arrestors shall not fail due to contamination. The 11kV arrestors housing shall be designed for pressure relief class as given in Technical Parameters of the specification.
- 2.4.3.** Sealed housings shall exhibit no measurable leakage.

**2.5. ARRESTOR MOUNTING**

The arrestors shall be suitable for mounting on 4 pole/2 pole structure used for pole/plinth mounted transformer and for incoming and outgoing lines. Arrester may also be required to be mounted on a bracket provided in the Transformers.

**2.6. FITTINGS & ACCESSORIES**

- 2.6.1.** The surge arrester shall be complete with fasteners and terminal connectors.

**2.6.2.** The terminals shall be non-magnetic, corrosion proof, robust and of adequate size and shall be so located that incoming and outgoing connections are made with minimum possible bends. The top metal cap and base of surge arrester shall be galvanized. The line terminal shall have a built in clamping device which can be adjusted for both horizontal and vertical take off.

**2.7. TESTS**

**2.7.1. Test on Surge Arrestors**

The Surge Arrestors offered shall be type tested and shall be subjected to routine and acceptance tests in accordance with IS : 3070 (Part-3)-/IEC:600994. In addition, the suitability of the surge arresters shall also be established for the followings.

- i) **Acceptance tests**
  - a) Measurement of power frequency reference voltage of arrester units.
  - b) Lightning impulse residual voltage on arrester units (IEC clause 6.3.2)
  - c) Internal ionization or partial discharge test
  
- ii) **Special Acceptance tests:**
  - a) Thermal stability test (IEC clause 7.2.2)
  - b) Watt loss test.
  
- iii) **Routine tests**
  - a) Measurement of reference voltage
  - b) Residual voltage test of arrester unit
  - c) Internal ionization or partial discharge test
  - d) Sealing test
  - e) Verticality check on completely assembled surge arresters as a sample test on each lot if applicable.

iv) **Type Tests**

Following shall be type test as per IS 3070 (Part 3): 1993 or its latest amendment

1.	Insulation Withstand test a) Lightning Impulse
2.	Residual Voltage Test a) Steep current impulse residual voltage test b) Lightning impulse residual voltage test
3.	Long duration current impulse withstand test
4.	Switching surge operating duty test
5.	Power frequency voltage Vs. Time characteristics
6.	Accelerated Ageing test
7.	Pressure relief test c) High Current

8.	Artificial pollution test (for porcelain housing)
9.	Seismic Test
10.	Partial Discharge test
11.	Bending test
12.	a) Temperature cycle test (for porcelain housing) b) Porosity test (for porcelain housing)
13.	Galvanising test on metal parts
14.	Seal Leakage test (for porcelain housing)
15.	Seal leak test and operation tests ( for surge monitor)
16.	Weather ageing test (for polymer housing)

**2.7.2.** The maximum residual voltages corresponding to nominal discharge current of 10 kA for steep current, impulse residual voltage test, lightning impulse protection level and switching impulse level shall generally conform to Annex-K of IEC-99-4.

**2.7.3.** The contractor shall furnish the copies of the type tests and the characteristics curves between the residual voltage and nominal discharge current of the offered surge arrester and power frequency voltage v/s time characteristic of the surge arrester subsequent to impulse energy consumption as per clause 6.6 of IS:3070 (Part-3) offered alongwith the bid.

**2.7.4.** The surge arrester housing shall also be type tested and shall be subjected to routine and acceptance tests in accordance with IS :5621.

**2.7.5. Galvanization Test**

All Ferrous parts exposed to atmospheric condition shall have passed the type tests and be subjected to routine and acceptance tests in accordance with IS:2633 & IS 6745.

**2.8. NAME PLATE**

**2.8.1.** The name plate attached to the arrester shall carry the following information:

- Rated Voltage
- Continuous Operation Voltage
- Normal discharge current
- Pressure relief rated current



- Manufacturers Trade Mark
- Name of Sub-station
- Year of Manufacturer
- Name of the manufacture
- Name of Client-
- Purchase Order Number along with date

**2.9. DRAWINGS AND INSTRUCTION MANUALS**

Within 15 days of receipt of the order, the successful tenderer shall furnish to the purchaser, the following drawings and literature for approval:

- (i) Outline dimensional drawings of Surge Arrestor and all accessories.
- (ii) Assembly drawings and weights of main component parts.
- (iii) Drawings of terminal clamps.
- (iv) Arrangement of earthing lead.
- (v) Minimum air clearance to be maintained of line components to ground.
- (vi) Name plate
- (vii) Surge monitor, if applicable.
- (viii) Instructions manual
- (ix) Drawing showing details of pressure relief valve
- (x) Volt-time characteristics of surge arrestors
- (xi) Detailed dimensional drawing of porcelain housing/Silicon polymeric i.e. internal diameter, external diameter, thickness, height, profile, creepage distance, dry arcing distance etc.

**2.10. TECHNICAL PARTICULARS**

**2.10.1.** The surge arrestors shall conform to the following standard technical requirements. The Insulation values shall be enhanced considering the altitude of operation & other atmospheric conditions.

**System Parameters**

i)	Nominal system voltage	11kV
ii)	Highest system voltage	12 kV
iii)	System earthing	Effectively earthed system
iv)	Frequency (Hz)	50
v)	Lightning Impulse withstand	75 Voltage (kVP)
vi)	Power frequency withstand	28 Voltage (kV rms)
vii)	Arrestor duty	
	-- Connection to system	Phase to earth
	-- Type of equipment to be protected	transformers & switchgear

**2.10.2. Surge Arrestors**

i)	Type	Gapless Metal oxide outdoor
ii)	Arrestor rating (kV rms)	9
iii)	Continuous Operating voltage	7.65 (kV rms)
iv)	Standard Nominal Discharge Current	10 Rating (kA) (8x20 micro impulse shape)
v)	Degree of protection	<b>IP 67</b>
vi)	Line discharge Class	2
vii)	Steep current at 10 kA	45
viii)	Lightning Impulse at 10 kA	40
ix)	Energy capability corresponding to	
	a) Arrestor rating (kj/kV)	4.5
	b) COV (kj/kV)	4.9
x)	Peak current for high current impulse operating duty of Standard TS for arrestor classification 10 kA	100

**2.10.3. Insulator Housing**

i)	Power frequency withstand test voltage (Wet) (kV rms)	28
ii)	Lightning impulse withstand/test voltage (kVP)	75

**2.10.4. Galvanisation**

i)	Fabricated Steel Articles	
	a) 5 mm thick cover	610 g/m <sup>2</sup>
	b) Under 5 mm but not less than 2 mm thickness	460 g/m <sup>2</sup>
	c) Under 2 mm but not less than 1.2 mm thickness	340 g/m <sup>2</sup>
ii)	Castings	
	Grey Iron, malleable iron	610 g/m <sup>2</sup>
iii)	Threaded works other than tubes & tube fittings	
	a) Under 10 mm dia	270 g/m <sup>2</sup>
	b) 10 mm dia & above	300 g/m <sup>2</sup>

NOTE- Surge Monitor shall have to be provided if covered in BPS.

**3. DISTRIBUTION CLASS SURGE ARRESTORS**

To be used in distribution Transformer Substations only.

**3.1. INTRODUCTION**

This section covers the specification of Distribution class Surge Arrestor for 11kV transmission lines, transformers etc.

**3.2. STANDARDS**

The design, manufacture and performance of Surge Arrestors shall comply with IS: 3070 Part-3 and other specific requirements stipulated in the specification. Unless otherwise specified, the equipment, material and processes shall conform to the latest applicable Indian/International Standards as listed hereunder:

IS:2071- 1993 (Part-1)	:	Methods of High Voltage Testing General Definitions & Test
IS:2071-1974 (part-2)	:	Test Procedures
IS:2629-1985	:	Recommended Practice for hot dip galvanizing on Iron & Steel
IS:2633-1986	:	Method for Testing uniformity of coating of zinc coated Articles.
IS3070-1993 (Part-3)	:	Specification for surge arrestor for alternating current systems. Metal-Oxide lightning Arrestors without gaps
IS:4759-1996	:	Specification for hot dip zinc coating on Structural Steel and Other allied products.
IS:5621-1980		Hollow Insulators for use in Electrical Equipment.
IS:6209-1982		Methods of Partial discharge measurement.
IS:6745		Method for determination of mass of zinc coating on zinc coated iron and steel articles
ANSI/IEEE-C.62.11 :		Metal oxide, Surge Arrestor for AC Power (1982) Circuits.
IEC –60099-4		Surge Arrestors

**3.2.1.** The equipment complying with any other internationally accepted standards shall also be considered if it ensures performance equivalent to or superior to the Indian Standards.

**3.3. GENERAL REQUIREMENT**

**3.3.1.** The metal oxide gap less Surge Arrestor without any series or shunt gap shall be suitable for protection of 11 kV side of Distribution Transformers, associated equipment and 11 kV lines from voltage surges resulting from natural disturbance like lightning as well as system disturbances.

**3.3.2.** The surge arrestor shall draw negligible current at operating voltage and at the same time offer least resistance during the flow of surge current.

**3.3.3.** The surge arrestor shall consist of non-linear metal oxide resistor elements placed in series and housed in electrical grade porcelain housing / silicon polymeric of specified Creepage distance.

**3.3.4.** The assembly shall be hermetically sealed with suitable rubber gaskets with effective sealing system arrangement to prevent ingress of moisture.

**3.3.5.** The surge arrestor shall be provided with line and earth terminals of suitable size. The ground side terminal of surge arrestor shall be connected with 25x6 mm galvanized strip, one end connected to the surge arrestor and second end to a separate ground electrode. The contractor shall also recommend the procedure which shall be followed in providing the earthing/system to the Surge Arrestor.

- 3.3.6.** The surge arrester shall not operate under power frequency and temporary over voltage conditions but under surge conditions, the surge arrester shall change over to the conducting mode.
- 3.3.7.** The surge arrester shall be suitable for circuit breaker performing 0-0.3 min-CO-3 min-CO- duty in the system.
- 3.3.8.** The reference current of the arrester shall be high enough to eliminate the influence of grading and stray capacitance on the measured reference voltage.
- 3.3.9.** The Surge Arrester shall be thermally stable and the contractor shall furnish a copy of thermal stability test with the bid.
- 3.3.10.** The arrester shall be capable of handling terminal energy for high surges, external pollution and transient over voltage and have low losses at operating voltages.

**3.4. ARRESTOR HOUSING**

- 3.4.1.** The arrester housing shall be made up of porcelain/*silicon polymeric* housing and shall be homogenous, free from laminations, cavities and other flaws of imperfections that might affect the mechanical and dielectric quality. The housing shall be of uniform **brown (for porcelain)/ Grey (for silicon polymeric)** colour, free from blisters, burrs and other similar defects.
- 3.4.2.** The housing shall be so coordinated that external flashover shall not occur due to application of any impulse or switching surge voltage upto the maximum design value for arrester. The arrestors shall not fail due to contamination.
- 3.4.3.** Sealed housings shall exhibit no measurable leakage.

**3.5. ARRESTOR MOUNTING**

The arrestors shall be suitable for mounting on 4 pole/2 pole structure used for pole mounted transformer and for incoming and outgoing lines.

**3.6. FITTINGS & ACCESSORIES**

- 3.6.1.** The surge arrester shall be complete with disconnecter and terminal connectors and all other accessories.
- 3.6.2.** The terminals shall be non-magnetic, corrosion proof, robust and of adequate size and shall be so located that incoming and outgoing connections are made with minimum possible bends. The top metal cap and base of surge arrester shall be galvanized. The line terminal shall have a built in clamping device which can be adjusted for both horizontal and vertical take off.

**3.7. TESTS**

**3.7.1. Test on Surge Arrestors**

The Surge Arrestors offered shall be type tested and shall be subjected to routine and acceptance tests in accordance with IS : 3070 (Part-3)-1993. In addition, the suitability of the surge arresters shall also be established for the followings

- a) **Acceptance tests:**
  - i) Measurement of power frequency reference voltage of arrester units.
  - ii) Lightning impulse residual voltage on arrester units (IEC clause 6.3.2)

- iii) Internal ionization or partial discharge test
  
- b) **Special Acceptance tests:**
  - i) Thermal stability test (IEC clause 7.2.2)
  
- c) **Routine tests:**
  - Measurement of reference voltage
  
  - i) Residual voltage test of arrester unit
  - ii) Internal ionization or partial discharge test
  - iii) Sealing test
  - iv) Verticality check on completely assembled surge arresters as a sample test on each lot if applicable.
  
- d) **Type tests:** Following shall be type test As per IS 3070 (Part 3)-/IEC;60094 or its latest amendment

1.	Insulation Withstand test a) Lightning Impulse voltage test b) Power Frequency (Dry & Wet)
2.	Residual Voltage Test a) Steep current impulse residual voltage test b) Lightning Impulse Residual Voltage Test
3.	Long duration current impulse withstand test
4.	High current impulse operating duty test
5.	Power frequency voltage Vs. Time characteristics
6.	Accelerated Ageing test
7.	Artificial pollution test (for porcelain housing)
8.	Partial discharge test
9.	Visual Examination (for porcelain housing)
10.	a) Temperature cycle test (for porcelain housing)
11.	Mechanical Failing Load test (Bending Strength test)

12.	Uniformity of Zinc coating, Mass of zinc coating
13.	Time versus current curve (for disconnecter)
14.	Weather ageing test (for polymer housing)

**3.7.2.** The maximum residual voltages corresponding to nominal discharge current of 5 kA for steep current, impulse residual voltage test, lightning impulse protection level and switching impulse level shall generally conform to Annex-K of IEC-99-4.

**3.7.3.** The contractor shall furnish the copies of the type tests and the characteristics curves between the residual voltage and nominal discharge current of the offered surge arrester and power frequency voltage v/s time characteristic of the surge arrester subsequent to impulse energy consumption as per clause 6.6.7 of IS:3070 (Part-3) offered alongwith the GTP.

**3.7.4.** The surge arrester housing shall also be type tested and shall be subjected to routine and acceptance tests in accordance with IS: 5621

**3.7.5. GALVANIZATION TEST**

All Ferrous parts exposed to atmospheric condition shall have passed the type tests and be subjected to routine and acceptance tests in accordance with IS:2633 & IS 6745.

**3.7.6. TEST ON SURGE ARRESTOR DISCONNECTORS**

The test shall be performed on surge arrestors which are fitted with arrester disconnecter or on the disconnecter assembly alone if its design is such as to be un-affected by the heating of adjacent parts of the arrester in its normally installed portion in accordance with IS:3070 (Part-3)

**3.8. NAME PLATE**

**3.8.1.** The name plate attached to the arrester shall carry the following information:

- Rated Voltage
- Continuous Operation Voltage
- Normal discharge current
- Manufacturers Trade Mark
- Year of Manufacturer
- Name of the manufacture
- Name of Client-
- Purchase Order Number along with date

**3.9. DRAWINGS AND INSTRUCTION MANUALS**

The successful bidder shall furnish to the purchaser the following drawings and literature for approval:

- (i) Outline dimensional drawings of Surge Arrestor and all accessories.
- (ii) Assembly drawings and weights of main component parts.
- (iii) Drawings of terminal clamps.
- (iv) Arrangement of earthing lead.
- (v) Minimum air clearance to be maintained of line components to ground.
- (vi) Name plate
- (vii) Instructions manual
- (viii) Drawing showing details of pressure relief valve
- (ix) Volt-time characteristics of surge arrestors
- (x) Detailed dimensional drawing of porcelain housing/Silicon polymeric i.e. internal diameter, external diameter, thickness, height, profile, creepage distance, dry arcing distance etc.

**3.10. TECHNICAL PARTICULARS**

**3.10.1.** The surge arrestors shall conform to the following standard technical requirements. The Insulation values shall be enhanced considering the altitude of operation & other atmospheric conditions.

**System Parameters**

i)	Nominal system voltage	11kV
ii)	Highest system voltage	12 kV
iii)	System earthing	Solidly earthed system
iv)	Frequency (Hz)	50
vii)	Lightning Impulse withstand	75 Voltage (kVP)
viii)	Power frequency withstand	28 Voltage (kV rms)
vii)	Arrestor duty	
	-- Connection to system	Phase to earth
	-- Type of equipment to be protected	11 kV transformers & switchgear

**3.10.2. Surge Arrestors**

i)	Type	Gapless Metal oxide outdoor
ii)	Arrestor rating (kV rms)	9
iii)	Continuous Operating voltage (kV rms)	7.65
v)	Nominal Discharge Current	5 Rating (kA) (8x20 micro impulse shape)

v)	Long Duration discharge class	Distribution class
vi)	Maximum residual voltage (kV peak) a) at 5 kA	27
vii)	Partial discharge at 1.05 COV not greater than	50 (PC)
viii)	High current impulse withstand voltage at 5 kA (kVp)	65

**3.11. INSULATOR HOUSING**

i)	Power frequency withstand test voltage (Wet) (kV rms)	28
ii)	Lightning impulse withstand/tests voltage (kVP)	75
iii)	Creepage distance not less than (mm)	300

**3.12. GALVANISATION**

i)	Fabricated Steel Aticles	
	a) 5 mm thick cover	610 g/m <sup>2</sup>
	b) Under 5 mm but not less than 2 mm thickness	460 g/m <sup>2</sup>
	c) Under 2 mm but not less than 1.2 mm thickness	340 g/m <sup>2</sup>
ii)	Castings	
	Grey Iron, malleable iron	610 g/m <sup>2</sup>
iii)	Threaded works other than tubes & tube fittings	
	a) Under 10 mm dia	270 g/m <sup>2</sup>
	b) 10 mm dia & above	300 g/m <sup>2</sup>





**32 LED Self Ballasted Lamps (Retrofit LED Lamp)**

1. Lamp Terminology: Self Ballasted LED Lamp retrofits for GLS lamp, cap size E27.
2. Technical Requirement: The lamps shall conform to 16102 (Part 1) for safety requirements. The test method for performance requirement shall be as per IS 16102(Part 2). The performance of lamps shall be as specified in the following table.
3. LED Chip conformity should mandatory be as per LM80.
4. Lamp Specifications:

Sl. No.	Test Parameters	Requirements	Referred Standard IS/IEC
1	Rated Wattage	Upto 9 W	IS 16102 (Part 2)
2	Cap Type	E27	IS 16102 (Part 1)
3	Efficacy (lm/w)	Minimum 80 lumen/watt	IS 16102 (Part 2)
4	Minimum operating input voltage	AC 144 V to 288 V	Shall be able to operate satisfactorily
5	Rated Voltage	Up to and including 250 V AC; in case of voltage range - 220 V to 240 V, AC	
6	Rated frequency	50 Hz	IS 16102(Part 1)
7	Light Source (LED chips/Die)	COB/SMD LED	LM 80 Compliant (Certified by the supplier)
8	CCT	Cool White (Cool daylight) 5700K (5665 ± 270) to 6500K(6432±340) Colour variation category, initial and maintained-B	IS 16102 (Part 2)
9	Beam angle	Minimum 140°	IS 16102 (Part 2)
10	Power factor	Minimum 0.9°	IS 16102 (Part 2)
11	Life	Average life 25,000 hrs	IS 16102 (Part 2)
12	CRI	Minimum 70	IS 16102 (Part 2)
13	Lumen Maintenance	Maximum 10% at 25% of rated lamp life(with a maximum duration of 6000hrs).	IS 16102 (Part 2)
14	Rated Luminous flux	Minimum 710 lm	IS 16102 (Part 2)
15	Safety requirement	Lamp shall meet all the safety requirements	IS 16102 (Part 1)
16	Guarantee	Minimum 3 years	
Making		On the product of packaging 1. This lamp is specially made for distribution under DDUGJY scheme 2. Year of Mfr/Batch No./Serial no. 3. Name/ Address of Manufacturer 4. "Not for SALE or retail market"	Marking shall be on the carton and the product as specified in IS 16102 (Part 1) and (Part 2)

<p>Certification endurance and switching immediately</p>	<p>For life, immediately self-certification to deter from sub-standard supply.          Later final life test after 9 months</p>	
--	--	--

5. Testing: LED lamps are tested for acceptance test as per clause 19.2, Page No.8 of IS 16102 (Part-II). The sampling of testing shall be as per clause 15, 16 & 17 of IS 16102 (Part-I).

Note- The rating of LED lamp shall be upto 9W and the lamp shall be capable to produce 710 Lumen conforming to IS 16102 (Part-II)

**33 1KV & 33 KV Metering Units**

**1 SCOPE:**

This specification covers design, engineering, manufacture, **assembly, stage testing, inspection**, testing before dispatch, supply and delivery of 11KV & 33KV CT PT Combined Metering unit Sets of class of accuracy **0.5 for 11 KV MU, 0.2 for 33 KV MU** as per the particulars given in the schedule attached.

**2 STANDARD:** Except where modified by this specification the component parts of the equipment shall comply with the following ISS available ( the latest versions).

Current T Transformers	:	IS 105/1992
Potential Transformers	:	IS 56/1992
HV Porcelain Bushing	:	IS 99/1986
Oil	:	IS 5/1983
Galvanization	:	IS 33
Primary Terminals	:	IS 601
	:	IS 5

**3 TYPE FOR 11 KV:** The metering transformer equipment should be of pole mounting type for outdoor use. They are to be used in 11KV Three Phase with solidly earthed neutral and suitable for 3 Phase 4 Wire 50 cycles network. The equipment is required for operation of HT Trivector Meters and should be oil cooled.  
**The CTPT sets shall have the following ratings:**

- i) Rated Voltage: 11 KV
- ii) Highest system voltage: 12 KV
- iii) Insulation level: 12 KV
- iv) Standard Impulse withstand voltage: 75 KV Peak
- v) One minute power frequency withstand Voltage

Primary	28 KV
Secondary	3 KV

- vi) Short time thermal current and its duration  
 6 KA for 1 sec for CT ratio below 50/5 A  
 13 .1 KA for 1 sec for CT ratio = 50/5 A(including 50/5 A)
- vii) Class of Accuracy: 0.5 (Negative (-ve) errors will not be acceptable.)
- viii) Rated burden per phase  
 For CTs: 15 VA  
 For PTs: 50 VA
- ix) Frequency: 50 HZ
- x) Maximum attainable winding temperature = 80 deg C
- xi) Minimum Phase to Phase distance = 255 mm
- xii) Shortest distance between metal part & earth = 190mm
- xiii) Creepage distance of HV bushing 300mm (Min)
- xiv) Gauge of MS Tank Min 5mm for top & bottom cover & 3.15 mm all other sides

- xv) Entire tank shall be hot dip galvanized.
- xvi) Bi-metallic terminal connector with a nut, plane washer, spring washer & Check nut suitable for aluminum conductor required for different rating of metering units. Six nos. to be provided with each metering units.

**4. TYPE FOR 33 KV:** The metering transformer equipment should be of pole mounting type for outdoor use. They are to be used in 33 kV Three Phase with solidly earthed neutral and suitable for 3 Phase 4 Wire 50 cycles network. The equipment is required for operation of HT Trivector Meters and should be oil cooled.

**The CTPT sets shall have the following ratings.**

- i) Rated Voltage: 33 KV
- ii) Highest system voltage: 36 KV
- iii) Insulation level: 36 KV
- iv) Standard Impulse withstand voltage: 170 KV peak
- v) One minute power frequency withstand Voltage

a. Primary	:	70 KV
b. Secondary	:	3 KV

- vi) Short time thermal current and its duration
  - 6 KA for 1 sec for CT ratio below 50/5 A
  - 13.1 KA for 1 sec for CT ratio for > 50/5 A (including 50/5A)
- vii) Class of Accuracy: 0.2 (Negative (-ve) errors will not be acceptable.)
- viii). Rated burden per Phase
  - 1. For CTs: 5 VA up to 50/5 A & 10 VA for => 50/5 A
  - 2. For PTs: 50 VA
- ix). Frequency: 50 HZ
- x). Maximum attainable winding temperature =80 deg C
- xi). Minimum Phase to Phase distance=430 mm
- xii). Shortest distance between metal part & earth = 380 mm
- xiii). Creepage distance of HV bushing 900mm (Min)
- xiv). Thickness of MS Tank Min 5mm for top cover & 3.15 mm bottom & all other side.
- xv). Entire tank shall be hot dip galvanized.
- xvi). Bi-metallic terminal connector with a nut, plane washer, spring washer & check nut suitable for aluminium conductor required for different rating of metering units. Six nos to be provided with each metering units.

**5. DESIGN:**

- a) The equipment shall be designed to ensure satisfactory operation under all conditions of service to facilitate easy inspection, cleaning and repairs.
- b) The design shall incorporate every reasonable precaution and provisions for safety of all those concerned in the operation and maintenance of the equipment. A pressure relief valve shall be invariably provided to the CT PT set. IT shall be provided at the top cover of the tank.
- c) All outdoor apparatus shall be so designed that water cannot collect at any point and enter the CT/PT set. The top cover of the tank, secondary terminal cover, inspection chamber cover plate is suitable bent at the edges (**at least 25mm bent**) so that the gaskets are not exposed to moisture.
- d) All connections and terminals shall be of sufficient size for carrying the specified currents

continuously without undue heating.

- e) All bolts, nuts, washers in contact with non-ferrous parts shall be of brass.
- f) All ferrous parts including bolts & nuts liable to corrosion, forming integral part of the equipment shall be smoothly and continuously hot dip galvanized.
- g) The secondary terminal box, inspection cover and oil gauge shall be arranged with MU.
- h) The core shall be high grade non-ageing electrical silicon laminated steel or of better grade of low hysteric loss and high permeability to ensure high accuracy, at both normal and over current/voltage.
- i) All winding shall be of insulated high grade Electrolytic copper wire and the manufacturing of the units shall be done completely closed and air-conditioned room otherwise fibre glass insulation sleeves are to be provided for primary winding. Details of winding and core shall be furnished.
- j) The CTPT set should have Three CTs and Three PTs with star/star connection.

#### **6. SEALING:**

Sealing bolts for sealing at 4 points on the secondary terminal box (both inner & outer door), inspection cover, the top cover of the tank shall be provided. This may be made by providing a hole on tail of corner bolts of adequate size to pass the sealing wire or above 13 SWG.

#### **7. FLUCTUATION IN VOLTAGE AND FREQUENCY:**

For continuous operation, entire equipment shall be subjected to variation of voltage up to plus 20 minus 30 frequency of plus or minus 5 percent.

#### **8. INSTRUMENT TRANSFORMERS:**

- d) The voltage and current transformers shall have normal continuous rating as per the schedule of requirement.
- b) The voltage transformer shall be so designed that the increased magnetizing currents due to any persisting over voltage, does not produce injurious over heating Phase barriers shall be provided.
- c) The peak value of the rated dynamic current shall not be less than 2.5 times the rated short time thermal current unless stated otherwise. (4.62 of ISS: 2705/Part-I of 1992, latest version).
- d) Modified polyester enamel copper wire is to be used for winding and it shall conform to IS-4800/Part-V (latest version).
- e) The terminals of the instrument transformer shall be clearly marked by distinctive letters as stated in Annex "C" of ISS: 3156/Part.I/1992 (latest version) for voltage transformer and Annex "C" of IS-2705/Part.I/1992 (latest version) for current transformers.
- f) The winding shall be neatly laid and anchored.
- g) The metering set tank and other metal parts shall be galvanized both inside & outside as per latest IS applicable.

#### **9. INCOMING SIDE:**

**TERMINALS: Brass rods 12mm dia for Primary and 6 mm dia for secondary.**

Bushing for outgoing side of CT/PT set :

The porcelain portion of HT bushings shall be of standard make and conform to IS-2099/1996.

The dimensions of the bushings shall conform to I S - 33 4 7

/Part.III/19 The minimum phase-to-phase clearance shall be as per IS.

**The tests as per IS-2099/1962 shall be conducted on the transformer bushings as detailed below:**

- a) Dry flash over voltage.
- b) Wet flashover voltage.
- c) Dry 1 Min. withstand volt.
- d) Impulse withstand voltage (1.2/50 Micro Seconds –ve wave)
- e) Manufacturer's test certification may be furnished for every lot of offer.

The bushings shall be of reputed manufacturers like M/s. Jayashree Insulators, M/s. WS Industries, M/s. BHEL, M/s. Allied Ceramics, M/s. India Potteries and M/s. IEC which are having complete testing facilities.

The bushing stems shall be provided with suitable bimetallic connectors so as to connect the jumper without disturbing the bushing stem.

f) The bush rod stem length should be at least 40 mm and 3 nuts with 2 flat washers of brass material should be provided with each bush rod.

**10. STEEL TANK:**

The oil filled container incorporating the voltage transformers and current transformers should be fitted with incoming and outgoing primary terminals and secondary terminal box. The secondary terminal box shall be arranged on sides. The general arrangement drawing with 3 bushing on the incoming side and 3 bushings on the outgoing side shall be submitted along with tender.

The tank shall be built with a plate of 5 mm thick top and 3.15 mm sides and bottom end with all fittings shall be capable of withstanding without leakage or distortion at the standard test pressure. All joints of the tank and fittings shall be hot oil tight and no leakage should occur during service. Both side of the joint should have continuous welding.

- a) It shall be provided with an oil gauge as shown. The oil gauge glass shall be fixed to the side of the raised wall of the inspection box.
- b) The tank shall be provided with necessary lifting lugs. Tank including top cover shall be hot deep Galvanized.
- c) The secondary terminal box cover, tank cover and inspection cover and other vertical joints where gaskets are used shall be suitably bent at least 25 mm bent with necessary sealing arrangement with sealing bolts at all corners and bolts should be at least 10 mm diameter GI bolts spaced maximum 70 mm apart. This is to safeguard against seepage of water into tank in case of damaged gasket.
- d) The 6 mm gaskets shall be dovetailed without joints to prevent moisture entry. In case of dovetailed joint, they shall not be more than two. The gaskets shall be of good quality Neoprene or superior quality rubberized gasket.
- e) **EARTHING:** Two earthing terminals shall be adequate size protected against corrosion and metallicly clean and identified by means of the sign marked in a legible and indelible manner on or adjacent to the terminals.

- 1 All bolts should be provided with 2 flat washers and a spring washer with a nut.
  - 2 Conservator should not be provided for these CTPT sets.
  - 3 The Secondary terminal box incoming hole should be 32 mm diameter and at a suitable height from bottom to avoid replacement/ modification of secondary wires pipe when CTPT set is replaced. The secondary terminals size should be 6 mm diameter, 25 mm stem length, 2 flat washers with 3 nuts of brass material should be provided. The terminals should be provided at least 70 mm height from incoming hole and clearances shall be as per IS to avoid shorting terminals due to secondary wires pipe.
- f) Secondary chamber shall have double door (inner & outer) with suitable arrangement for sealing of both the doors. The inner door shall be of transparent Polycarbonate so that secondary terminal connections can be viewed without breaking the inner door seals.
- g) The following details of equipment shall be engraved on tank with at least 10 mm letters.
1. Make
  2. Ratio
  3. Class of accuracy
  4. Serial No:
  5. Month & year of manufacturing
  - 6 . Property of Employer.
- 66 months guarantee embossed plate shall be welded opposite side of name plate.

**11. MOUNTING ARRANGEMENT:**

The under base of all CTPT sets shall be provided with two 75x40mm GI channels and foundation dimensions shall be suitable placing with tank base uniform for all sets with only  $\pm 2$  mm tolerance, to avoid modification of structure / plinth, whenever CTPT set is replaced

- 12. OIL:** The insulation oil used in the tank shall comply with the requirements specified in latest relevant IS: 335/93 and as per Annexure-C.

**13. GUARANTEED TECHNICAL PARTICULARS:**

The Technical Particulars as specified in IS shall be guaranteed. Every tenderer should furnish the particulars required and guarantee the values so furnished for the supplies.

**14. TESTS:**

**TYPE TESTS:** The equipment offered shall be fully type tested from recognized standard govt. national laboratory by the bidder as per the relevant certificates shall be furnished. The bidders also furnish type test certificates for bushings and oil along with the Bid. **The type test certificates shall be not older than (5) years.**

**TYPE TESTS FOR CTs:**

- a) Verification of terminal marking and polarity
- b) Short time current Test.
- c) Temperature rise test.
- d) Lightning Impulse test
- e) High Voltage Power frequency wet withstand voltage test.
- f) Determination of errors or other characteristics according to the requirements of the appropriate designation or accuracy class.



**TYPE TESTS FOR PTs:**

- a) Verification of terminal marking and polarity.
- b) High voltage Power frequency wet withstand voltage test.
- c) Power frequency dry withstand tests on Primary winding.  
Power frequency dry withstand test on Secondary winding.
- d) Determination of errors according to the requirements of the appropriate accuracy class.
- e) Temperature rise test.
- f) Impulse Voltage test.
- g) Lightning Impulse test

**TYPE TESTS FOR TRANSFORMER BUSHINGS:**

- i) Dry flash over voltage.
- ii) Wet flash over voltage.
- iii) Dry 1 Minute withstand voltage.
- iv) Impulse withstand voltage (1.2/50 Micro Seconds –ve wave)

**ACCEPTANCE AND ROUTINE TESTS:**

The following shall be conducted as per IS: 3156 (Latest version).

- i) Verification of Terminal marking and polarity.
- ii) Power frequency/ dry withstand tests on primary windings.
- iii) Power frequency dry withstand tests on secondary windings.
- iv) Determination of errors according to the requirements of the appropriate accuracy class.
- v) Temperature rise test.
- vi) Air pressure test on empty tank of M U opened for verification test (One for every lot offered for pre-dispatch inspection)
- vii) All acceptance and routine tests as stipulated in the relevant standards shall be carried out by the manufacturer in presence of Employer representatives.

**15. DRAWINGS AND LEAFLETS (along with tender):**

Two sets of drawings showing clearly the general arrangements, sectional views, fitting details, electrical connections, *foundation details*, *overall dimensions* and design features of each component part should accompany the tender. The contractor has to submit clear & detail drawing with description how he will arrange the double door system in secondary chamber with sealing. Technical leaflets giving the operating instructions should also be furnished along with tender. Literature and drawings are to be sent along with each equipment while dispatching, after approval of Project Manager.

**16. DEVIATIONS:**

The deviations between these CTPT sets and NABL approved Standard Lab (CPRI, ERDA, etc.,) type tested CTPT set along with detailed reasons for deviations if any shall be submitted along with tender.

**17. TOLERANCES:**

Unless otherwise specified herein the test value of the transformers supplied should be within the tolerance permitted in the IS on the guarantee values.

**18. SEALING OF CTPT SETS AFTER TESTING AND INDIVIDUAL TEST REPORTS:**

After witnessing testing on sample quantity and physical inspection of all offered CTPT sets, the purchaser's representative will provide numbered plastic seal bits to two opposite corners of tank, Secondary Chamber and inspection cover of all offered CTPT sets, for delivery of correct inspected materials only. The manufacturer has to provide test report duly mentioning all test results, seal bit

numbers and name & address of Employer representative after inspection is over. The seal bit numbers shall also be mentioned in the test reports signed by Employer representative submitted for delivery instructions.

**19. INSPECTION AND TESTING OF TRANSFORMER OIL:**

To ascertain the quality of transformer oil the manufacturer's test report should be submitted at the time of inspection. Arrangements should also be made for testing the transformer oil, after taking out the samples from the manufactured CTPT sets and tested in the presence of Employer representative (or) if desired, in an independent laboratory manufactured CTPT sets and tested in the presence of Employer representative (or) if desired, in an independent laboratory.

**20. DEPARTURE FROM SPECIFICATION:**

If the tenderer wishes to depart from this specification in any respect, he shall draw the attention to such points of departure explaining fully the reasons therefore. Unless this is done the requirements of this specification will be deemed to have been accepted in every respect.

**21. NAME PLATE:**

The Purchase order No. and Date of purchase order, the words "**PROPERTY OF EMPLOYER NAME**". The name plate shall be non-detachable type & fixed with rivets, not with bolts & nuts. The name plate should bear year & month of manufacture & other data as per IS. Space should be provided to punch the date of installation by user group.

**22. WARRANTY:**

The manufacturer will warrant for the satisfactory functioning of the material / equipment as per specification for a minimum period of 66 months from the date of dispatch of the material / equipment in good condition indicating GP covering date upto -----

**23.** The tenderer shall indicate the source of all materials. He shall also indicate the name of the manufacturer and make of conductor, Transformer oil Electrical Steel Laminations, Construction Steel etc.

**24. FITTINGS:**

The following standard fittings shall be provided.

- a) Rating and terminal marking plates non detachable -1no.
- b) Earthing terminals with bolt, nuts & washers for connecting earth wire - 2Nos.
- c) Lifting lugs -4Nos.for main tank and 2Nos. for top cover.
- d) Pressure relief valve. – 1 no.
- e) Bimetallic terminal connectors on the HV bushings – 6 Nos.
- f) HV bushings Outdoor – 6 Nos.
- g) Secondary terminals bushings – 10 Nos
- h) Base channels 75 x 40 mm.
- i) 66 months guarantee embossed plate welded to tank opposite side of name plate.
- j) Tank and over all dimensions.
- k) Weight content of a) core b) windings c) tank & fittings d) weight/qty. of oil e) over all weight.

**SCHEDULE OF MATERIALS:**

<b>Sl. No.</b>	<b>Name of the Materials</b>
<b>1</b>	11KV Metering Unit (CTR = 10/5A)
<b>2</b>	11KV Metering Unit (CTR = 15/5A)
<b>3</b>	11KV Metering Unit (CTR = 20/5A)
<b>4</b>	11KV Metering Unit (CTR = 25/5A)
<b>5</b>	11KV Metering Unit (CTR = 30/5A)
<b>6</b>	11KV Metering Unit (CTR = 50/5A)
<b>7</b>	11KV Metering Unit (CTR = 100/5A)
<b>8</b>	11KV Metering Unit (CTR = 200/5A)
<b>9</b>	11KV Metering Unit (CTR = 400/5A)
<b>10</b>	33KV Metering Unit (CTR = 5/5A)
<b>11</b>	33KV Metering Unit (CTR = 10/5A)
<b>12</b>	33KV Metering Unit (CTR = 15/5A)
<b>13</b>	33KV Metering Unit (CTR = 20/5A)
<b>14</b>	33KV Metering Unit (CTR = 25/5A)
<b>15</b>	33KV Metering Unit (CTR = 30/5A)
<b>16</b>	33KV Metering Unit (CTR = 50/5A)
<b>17</b>	33KV Metering Unit (CTR = 100/5A)
<b>18</b>	33KV Metering Unit (CTR = 200/5A)

## 34 Energy Meter

### 1.1 GENERAL

This Chapter describes the common requirement for static energy meter required for HT feeder, 3-Phase Distribution Transformer, 1-Phase Distribution Transformer, Single Phase whole current meter.

Necessary software for downloading the data through CMRI and uploading to computer shall be provided. No cost shall be charged for providing the software by the manufacturer to Owner.

The seals & sealing specifications are given in *Annexure A*

All meter shall have BIS certification mark. Valid BIS license must be submitted along with the bid.

### 1.2 STANDARDS APPLICABLE

Unless otherwise specified elsewhere in this specification, the performance & testing of the meters shall conform to the following Indian/International standards with updated and latest amendments/revisions thereof.

Sl.No.	Standard No.	Title
1.	IS 14697-1999	AC Static Watt-hour Meters for active energy Class 0.5 & 0.2
2.	IS 12063	Specification for degree of protection
3.	IS 14772	Specification for boxes for enclosure of electrical accessories
4.	IS 13779/1999	AC Static Watt-hour Meters for active energy Class 1.0 & 2.0
5.	CBIP Report No.-325	Specification for AC Static Electrical Energy Meters
6.	CBIP Technical Report No. 111	Specification for common meter reading instrument
7.	IS:9000	Basic environment testing procedure for electric and electronic item
8.	IS:15959 with latest amendment	Data Exchange for Electricity Meter Reading, tariff & load control – Companion Specification

### 1.3 CLIMATIC CONDITION

The meter should be able to perform satisfactorily in moderately hot and humid climate, conducive to rust and fungus growth as specified in Section-I. The climate conditions are also prone to wide variations in the ambient conditions. The meter shall work satisfactorily even under lightning conditions and also the meter performance and life shall not be affected due to smoke present in the atmosphere.

\* The specifications are applicable for meter installation upto an altitude of 2200 meter above mean sea level. For meters to be used for an altitude of above 2200 MSL necessary corrections shall have to be carried out in BIL and one minute power frequency with stand voltage capability as per relevant standard.

### 1.4 SUPPLY SYSTEM

Type of meter	Input Voltage	Input Current	Burden	Type /Phase	Starting Current	Accuracy
HT Feeder meter	3 x 110 volt phase to phase	1A / 5A	1.5 Watts/phase or 10 VA/phase for voltage circuit and 1 VA phase for each current circuit	3 phase 4 wire	0.1 % of basic	0.5
3-phase DT meter	415±20% phase to phase	5A	1.5 Watts/phase or 10 VA/phase for voltage circuit and 1 VA phase for each current circuit	3 phase 4 wire	0.1 % of basic	0.5
1-phase DT meter	240+20% -30% phase to neutral	5A	1.5 Watts/phase or 10 VA/phase for voltage circuit and 1 VA phase for each current circuit	1 phase 2 wire	0.1 % of basic	0.5
1-phase consumer meter	240 V Phase to neutral	5-30A, 10-60A	1.5 Watts/phase or 8 VA/phase for voltage circuit and 4 VA phase for each current circuit	1 phase 2 wire	0.4 % of basic	1.0
3-phase consumer meter	3x 240 V Phase to neutral	10-60A	1.5 Watts/phase or 8 VA/phase for voltage circuit and 4 VA phase for each current circuit	3 phase 4 wire	0.4 % of basic	1.0

### 1.5 POWER FACTOR RANGE

The meter shall be suitable for full power factor range from Zero (lag) to Unity to Zero (lead).

### 1.6 POWER SUPPLY VARIATION

Energy meter along with its accessories shall withstand following extreme operating conditions.

Voltage : 70% to 120 % of V ref

Frequency : 50 ± 5% Hz

The manufacturer can also offer meters, which can withstand higher variations.

### 1.7 MAXIMUM CONTINUOUS CURRENT

The maximum continuous current in meters shall be the current at which the meter purports to meet the accuracy requirement of the specification.

### 1.8 CALLIBERATION

The meter should be only factory calibrated and no modification of calibration should be possible at site to ensure non tampering of meter at site.

### **1.9 COMMUNICATION CAPABILITY**

The Meter shall be provided with a galvanically isolated optical communication port and communication capability as per IS 15959, so that it can be easily connected to a CMRI for data transfer.

### **1.10 NAME-PLATE MARKING OF THE METER**

The marking on every meter shall be in accordance with relevant clauses of standard. Every meter shall have name plate beneath the meter cover such that the name plate cannot be accessed without opening the meter cover and without breaking the seals of the meter cover and the name plate shall be marked distinctly and indelibly. The basic marking on the meter nameplate shall be as follows:

- a) –DDUGJY/IPDS
- b) Manufacturer's name & trade mark
- c) Type Designation
- d) No. of phases & wires
- e) Serial number
- f) Month and Year of manufacture
- g) Reference Voltage
- h) Rated secondary Current of CT, if applicable
- i) Reference Standard as applicable
- j) Principal unit(s) of measurement
- k) Meter Constant
- l) Class index of meter
- m) Property of <Name of owner>
- n) Purchase Order No. & Date
- o) Guarantee period

### **1.11 CALIBRATION AND TEST OUTPUT**

The meter should have test output accessible from the front and be capable of being monitored with suitable testing equipment. The operation indicator must be visible from the front. Test output device shall be provided in the form of one common/separate LED for KWh and KVARh as applicable with provision of selecting the parameter being tested. The test output device should have constant pulse rate in terms of pulse/unit energy.

The meter shall be tested, calibrated and sealed at works before dispatch. Further, no modification or calibration shall be possible at site by any means.

The resolution of the test output shall be sufficient to enable the static current test in less than 10 minutes.

### **1.12 GUARANTEE**

Manufacturer shall undertake a guarantee to replace the meters upto a period of 24 months from the date of installation or 36 months from date of supply, whichever is earlier. The meters, which are found defective/inoperative at the time of installation, or became inoperative/defective within the guarantee period shall be replaced by manufacturer within two months from receipt of report for such defective/inoperative meters.

**2.0 3 PHASE 4 WIRE 0.5 CLASS ENERGY METER FOR FEEDER****2.1 GENERAL & CONSTRUCTIONAL REQUIREMENTS**

- 2.1.1** Meters shall be designed and constructed in such a way so as to avoid causing any danger during use and under normal conditions. However, the following should be ensured.
- a) Personal safety against electric shock
  - b) Personal safety against effects of excessive temperature.
  - c) Protection against spread of fire
  - d) Protection against penetration of solid objects, dust & water
  - e) Detection against fraud
  - f) Detection against pilferage
- 2.1.2** The meter shall be designed with latest technology. The meter circuit should be housed in a safe, high grade engineering plastic / polycarbonate casing, which is of projection mounting type and is dust/moisture proof, conforming to IP-51. .
- 2.1.3** All insulating material used in the construction of meters shall be non-hygroscopic, non-ageing and of tested quality. All parts that are likely to develop corrosion shall be effectively protected against corrosion during operating life by providing suitable protective coating.
- 2.1.4** The meter shall be supplied with a terminal block cover. The meter base, meter cover, terminal block and shall be made of high grade fire resistant non-flammable reinforced, polycarbonate (not bakelite) or equivalent high grade engineering plastic and have terminal holes with sufficient size to accommodate insulation of the conductors, meeting the requirement of CBIP technical report CBIP325.
- 2.1.5** The terminal block cover should be separately sealable at two places and housed at the bottom of the meters and once sealed should prevent unauthorized tampering.
- 2.1.6** The terminal block should have sufficient insulating properties, mechanical strength and should have tin or nickel plated solid brass terminals with two fixing screws per terminal. The terminals should be designed to withstand high overload.
- 2.1.7** The meter should not get damaged or substantially influenced by the electromagnetic disturbances and electrostatic discharges caused by harmonics, voltage dips and short interruptions, transients, DC and AC magnetic field as per IS 14697
- 2.1.8** The meter shall have an operation indication device such as a blinking LED. The operation indicator shall be visible from the front of the meter and capable of being monitored conveniently with suitable testing equipment.
- 2.1.9** The meter shall conform to the degree of protection IP 51 but without suction in the meter as per IS: 12063 for protection against ingress of dust, moisture and vermin's.
- 2.1.10** The meter-base, meter cover, terminal block and terminal cover shall be made of, high grade, fire resistant, reinforced, non-flammable, polycarbonate or equivalent high grade and good quality engineering plastic.
- 2.1.11** The meter cover shall have transparent window or shall be transparent for easy reading of all the displayed values/parameters, name plate details and observation of operation indicator.
- 2.1.12** The terminal block, the terminal cover and the meter case shall ensure reasonable safety against the spread of fire. They should not be ignited by thermic overload of live parts in contact with them.

- 2.1.13** The meter shall have tin/nickel plated brass terminals. The terminals shall have suitable construction with barriers and cover to provide firm and safe connection of current and voltage leads of stranded copper conductors or copper reducer type terminal ends (thimbles).
- 2.1.14** The manner of fixing the conductors to the terminal block shall ensure adequate and durable contact such that there is no risk of loosening or undue heating. Screw connections transmitting contact force and screw fixing which may be loosened and tightened several times during the life of the meter shall be such that the risk of corrosion resulting from contact with any other metal part is minimized. Electrical connections shall be so designed that contact pressure is not transmitted through insulating material. The clearance and creepage distance shall conform to relevant clause of IS 14697:1999/CBIP technical report No.325.
- 2.1.15** The meter shall be compact in design. The entire construction shall be capable of withstanding stresses likely to occur in actual service and rough handling during transportation. The meter shall be convenient to transport and immune to shock and vibration during transportation and handling.
- 2.1.16** The meter shall have a design life to operate satisfactory for 10 years under normal electrical condition and guaranteed life of 24 months from the date of installation against manufacturing and design defects. The meters found defective within guaranteed period shall be replaced by manufacturer free of cost within two months of intimation.
- 2.1.17** The meter shall be provided with accurate quartz crystal based real time clock and calendar with the accuracy limit as per relevant standards. Meter shall have provision to synchronise the meter time with standard time through CMRI with proper security system.
- 2.1.18** The integration period shall be set as 30 minutes and subsequently can be changed using CMRI.
- 2.1.19** Vendor will give one copy of all the software's (meter reading software for CMRI, software for uploading data from CMRI to computer).
- 2.1.20** It should be possible to check the healthiness of phase voltages by displaying all the voltages on the meter display.
- 2.1.21** The Meter should have appropriate facilities to be read in absence of Power Supply.
- 2.1.22** The meter should work accurately irrespective of phase sequence of the mains supply.
- 2.1.23** The meter should remain powered up and functional even when either any two phases or phase & neutral are available to the meter
- 2.1.24** The meter shall record forwarded active energy, even if one or more CT's are reversed. The current vector direction shall always be considered as positive (import) for computation of energy and shall be added in main active energy register.
- 2.1.25** Data Security: The Meter shall have multilevel password for data protection and security as per IS 15959. The meter data retrieval shall be possible through authenticated CMRI. The meter shall support the event of change of TOD register timings / no. of TOD registers, demand integration period and /or setting the meter time through authenticated transaction and shall be logged as an event. The transaction events shall be available for viewing at BCS end.
- 2.1.26** The meter data shall be retrievable through CMRI and will be downloaded in the Base computer software for viewing, analysing and printing. The meter data downloaded at BCS end should be in user-friendly formats. The manufacturer shall supply the required software for base computer system. The base computer software shall have the facility to convert the required data (For billing, Energy Audit, tamper analysis purpose) in to xml format. This data should be possible to be used as input data for any other software to generate desired reports as per the utility requirement.
- 2.1.27** The meter shall have radio interference suppression such that it should not generate noise, which could interfere with the other equipment as per IS 14697.



**2.1.28** The meter shall have three fixing holes, one at the top and two at the bottom. The top hole shall be provided at the back of the meter so that holding screw is not accessible to the consumer after fixing the meters. The lower fixing screws shall be provided under the sealed terminal cover. The requisite fixing screws shall be supplied with each meter.

## **2.2 SEALING OF METER**

Reliable sealing arrangement should be provided to make the meter tamper proof and avoid fiddling or tampering by unauthorized persons. For this, at least two no. of seals on meter body, two no. of seals on meter terminal cover and one no. of seal on each communication port shall be provided. All the seals shall be provided in front side only. Please refer Annexure A for specification for sealing system.

## **2.3 CONNECTION DIAGRAM & TERMINAL MARKINGS**

The terminals shall be marked properly on terminal block for giving external connections. A diagram of connections should be provided inside the cover of terminal block. The terminal cover shall be extended such that when it is placed in position it is not possible to approach the connections or connecting wires. The terminals and the screws shall be suitable to carry upto 150% of  $I_{max}$  safely. The terminals shall have suitable construction with barriers and covers to provide secure and safe connections.

## **2.4 REMOTE READOUT FACILITY, COMMUNICATION CAPABILITY**

The meter also shall have a sealable RS-232 / RS-485 communication port conforming to IS 15959 protocol to communicate to central location.

## **2.5 SOFTWARE**

Licensed copies of the software (meter reading software for CMRI, software for downloading/uploading data from CMRI to computer) shall be made available and shall be installed on each common meter reading instrument (CMRI) and Base computer by the manufacturer. *Software shall be provided to owner by the manufacturer free of cost.*

Common Meter Reading Instrument (CMRI) would be loaded with user-friendly software (MS-DOS 5.0 or higher version compatible) for reading, downloading meter data and Time of Day (TOD) programming in the meter.

Windows based *user interactive* Software for receiving data from CMRI and downloading instructions from base computer to CMRI. This software should have, amongst other requirements, features and facilities as described later in this specification, the facility to convert meter reading data into a user definable DBF (Access) or spreadsheet or ASCII format or any other format for integrating with the Employer's billing system as desired/required by the utility. Here again an "Export wizard" or similar utility shall be available whereby user can select file format, the variable data to export, the field width selection of each variable so that it may be possible for the user to integrate the same with the user's billing data and process the selected data in desired manner.

The software shall have the flexibility to generate the following sets of reports.

- Load survey reports
- Tamper reports

Tamper reports to include for a pre-determined duration or month wise, tamper count, tamper duration and tamper history for each of the meters.

**2.5.1** Vendor will provide soft copy of all the software in CD form along with the meters supplied.

- 2.5.2** Vendor to install & demonstrate working of software programmes of other meter manufacturers on the CMRI's to be supplied with this package

The specification of CMRI are presented as Annexure B

## **2.6 DISPLAY**

A real time quartz clock shall be used in the meter for maintaining time and calendar date. The maximum drift shall not exceed 5 minutes per year. The uncertainty of setting initial time shall not exceed  $\pm 30$  Seconds with respect to Indian standard time (Ref NPL New Delhi).

Facility for adjustment of real time shall be provided through CMRI with proper security.

The meter shall have a minimum 7 digits, 7segment display of liquid crystal display (LCD). The minimum digit height shall be 7 mm. Provision shall be made to read consumption in either whole units or decimal multiples. .

The display shall remain on the screen till operator presses button for subsequent display or 10 sec whichever is earlier.

The meter should have non-volatile memory, so that the registered parameters will not be affected by loss of power. The non-volatile memory should have a minimum retention time of 10 years under unpowered condition.

## **2.7 DISPLAY SEQUENCE**

The meter shall display the required parameters in two different modes as follows:

### **A. Auto Display Mode**

Display test (LCD Segment check)

- Real time & date
- Active energy forwarded
- Reactive energy lag
- Reactive energy lead
- Apparent energy
- Maximum Demand forwarded
- MD occurrence date and time
- MD reset count
- Instantaneous average 3  $\phi$  PF
- Instantaneous frequency
- Phase voltages R,Y,B
- Phase currents R,Y,B
- Cumulative power on hours of current month

**B. Push Button Mode**

All above & the following

- Present CT status
- Last occurrence tamper ID
- Date and time of last tamper occurrence
- Last restoration tamper ID
- Date and time of last tamper restoration
- Cumulative tamper count
- TOD Register [Active forwarded energy (8 Nos)]
- TOD Register [Apparent forwarded energy (8 Nos)]
- TOD Register [Apparent forward MD (8 Nos)]
- Cumulative power on hours

**C. Download Parameters with CMRI**

All above including following

- Energy registers
- Billing registers
- TOD Registers
- Load survey data
- Tamper and fraud (all event details with date and time)
- History of monthly Energy, Maximum Demand, Average power factor for the last 12 months

**2.8 MAXIMUM DEMAND REGISTER**

The maximum demand is to be monitored during each demand interval set with 15 / 30 minutes integration and the maximum of these in a month shall be stored. Whenever MD is reset the maximum demand value so registered shall be stored along with date and time. The registered demand and the number of times the MD is reset shall also be displayed and the information stored.

**2.9 MAXIMUM DEMAND RESET**

Facility for auto reset of MD at 00.00 hrs of first of every month shall be provided for which minimum 30 years calendar shall be programmed by the manufacturer.

The meter shall display the maximum demand reset count.

**2.10 LOAD SURVEY CAPABILITY**

Load survey shall be available for at least 35 days with 30 minutes load survey integration period for following parameters. Vendor shall provide necessary facility to transfer data through CMRI.

- a. kWh forwarded
- b. kVAh forwarded
- c. kVARh lag/lead

- d. Voltage Phase wise
- e. Current Phase wise

In addition meter should have facility for daily profile for active and apparent energy.

The load survey data, abnormality event information and instantaneous parameters data shall all be retrievable through the meter's communication port from a common meter reading instrument (CMRI) and shall be transferred (downloaded) to a PC with user friendly Windows based software to get complete details in numerical and/or graphic form. The necessary feature shall be available in the software used for uploading data from CMRI to computer and shall be provided by the manufacturer with complete details.

The meter shall have sufficient non-volatile memory for recording history of energy parameters for last twelve billing cycles (Bill date shall be 00 hrs of the 1<sup>st</sup> date of the calendar month by default – programmable) and information should be made available at the BCS end:

**2.11 TIME-OF-DAY (TOD) TARIFF/DEMAND**

The meter should have provision of registering the time-of- day energy and maximum demand. It shall be possible to define TOD register for active forwarded, apparent forwarded energy type.

The meter should have in-built capacity to define up to eight (8) time zones through operation of CMRI .The change of the TOD time-period(s) or changing number of TOD zones should be possible through CMRI with special authenticated command from the software used for uploading data from CMRI to computer so that only authorised person(s) can make such changes.

**2.12 SELF DIAGNOSTIC FEATURE**

**2.12.1** The meter shall be capable of performing complete self-diagnostic check to monitor the circuits for any malfunctioning to ensure integrity of data memory location at all times. The meter shall have indications for unsatisfactory/nonfunctioning/malfunctioning of the following:

- a) Real Time and Date
- b) All display segments as per the requirement

**2.12.2** While installing the meter, it should be possible to check the correctness of Current and Voltage Transformer connections to the meter and their polarity from the functioning of the meter for different voltage injections with the help of vector/phasor diagrams. For this purpose a suitable software for field diagnosis of meter connections with the help of Meter Reading Instrument should be supplied.

**2.13 TAMPER & FRAUD PROTECTION**

The meter shall function properly under following common abnormal conditions:

1. Phase sequence reversal	The meter shall keep working accurately irrespective of the phase sequence of the supply.
2. Current reversal/CT polarity reversal	The meter shall log energy in forward direction even if the current is flowing in reverse direction in one or more phases.
3 External magnetic influence	The meter shall comply to influence of external magnetic field (AC Electro Magnet or DC Magnet) as per IS 14697

Beside this the meter should have features to detect the occurrence and restoration of, at least, the following common abnormal events:

- i. **Missing Potential & Potential imbalance:** The meter shall be capable of detecting and recording occurrence and restoration with date and time the cases of Potential failure which could happen due to disconnection of potential leads (one or two), failure of phase line fuse from the Potential Transformer primary side. Meter shall also detect and log cases of voltage unbalance (5% for more than 5 minutes) of voltages.
- ii. **Voltage High / Voltage Low:** In case the average 3 phase voltage remains less (below 0.75Vref by default) than or above (above 1.15Vref by default) for a predefined period (30 minutes by default), the meter shall log such incidences with date & time. This abnormal condition shall be logged only when all the three-phase voltage is available.
- iii. **Current imbalance:** The meter shall be capable of detecting and recording occurrence and restoration with date and time of Current unbalance (30% or more for more than 15 minutes).
- iv. **Current Circuit Open:** The meter shall be capable of detecting and recording occurrences and restoration of opening of any one or two phases of current circuit which can happen due to intentional / accidental disconnection of current circuits. The meter shall be able to log abnormality conditions in current open event like CT leads burns, loose connection, CT winding open etc in the meter memory. No load condition should not be recorded in meter memory as a Current circuit open event.
- v. **Power on/off:** The meter shall be capable to record power on /off events in the meter memory. All potential failure should be recorded as power off event.

The meter shall record the total duration of the above abnormalities, time and date of their occurrences & restorations with a snap shot of electrical conditions viz. Voltage , current ,PF etc

Logic for calculation of voltage and current imbalance shall be furnished by the tenderer.

The meter shall keep records for the minimum last 250 events (occurrence + restoration) for above of abnormal conditions. It shall be possible to retrieve the abnormal event data along-with all related snap- shots' data through the meter's optical port with the help of a CMRI and download the same to the BCS where it shall be available for viewing. All this information shall be made available in simple and easily understandable format.

## **2.14 TAMPER LOGIC**

Properly designed meter event logic should be provided. There shall be separate compartments for logging of potential related event, current related event and power on/off event. The bidder should explain the events details in each compartment under their offer.

The logging of various events in each compartment should be as under:

Once one or more compartments have become full, the last event pertaining to the same compartment will be entered and the earliest (first one)-event should disappear. Thus, in this manner each succeeding event will replace the earliest recorded event, compartment wise. Events of one compartment/category should overwrite the events of their own compartment/category only.

A properly defined meter tamper logic should be provided. The tamper logic should be capable of discriminating the system abnormalities from source side and load side and it should not log/record tamper due to source side abnormalities.

There shall be three separate compartments for logging of different types of tampers as per IS 15959.

## **2.15 TESTS**

Unless specifically waived off all acceptance tests shall be witnessed by the Employer.

### **2.15.1 Type Test**

Energy Meters offered shall be fully type tested as per IS 14697& IS 15959 with latest amendments at any of the NABL accredited test laboratories.

Type test certificate shall not be older than 3 years from the date of bid submission. Bid shall not be accepted without valid type test certificate.

### **2.15.2 Acceptance Test**

Acceptance test shall be carried out as per IS 14697.

### **2.15.3 Routine Test**

All routine tests as specified in IS 14697 shall be carried out on each individual meter.

## **2.16 OTHER SALIENT FEATURES**

**2.16.1** It should be possible to check the healthiness of phase voltages by displaying all the voltages on the meter display.

**2.16.2** The meter shall have provision of reading through communication port in the absence of power.

**2.16.3** The meter should work accurately irrespective of phase sequence of the mains supply.

**2.16.4** The meter should remain powered up and functional even when either of the two phases or one phase along with neutral is available to meter.

**2.16.5** The meter casing arrangement shall be break to open type.

### **3.0 Three Phase, Four Wire, 0.5 Class, Energy Meter for 3-Phase Distribution Transformer**

#### **3.1 CT REQUIREMENT**

The Meter shall be supplied with four nos of C.T's with primary current capacity as required for its intended use. Since the meters are to be used with external CT of suitable ratio please refer CT specification provided separately.

Alternatively meters with Integrated CT complying with IS 13779 for outdoor installation shall be acceptable.

#### **3.2 DISPLAY**

The Three phase meters shall be capable to measure & display parameters as given below. The meter should have provision for automatic recording of cumulative kWh at 24 hrs on the last day of the month for each calendar month and same should go to memory.

The digitally measured and processed value shall be displayed through LCD having minimum six digits to read upto one-tenth of kWh. The minimum character height shall not be less than 7 mm.

The Meter should have appropriate facilities to be read in absence of Power Supply.

#### **3.3 AUTO SCROLL DISPLAY**

- i) Cumulative kWh
- ii) Instantaneous Voltages
- iii) Instantaneous Currents
- iv) Cumulative kVAh
- v) Instantaneous pf phase-wise
- vi) Power on hours

#### **3.4 DISPLAY PARAMETERS (PUSH BUTTON)**

The display of following parameters shall be continuously scrolling one after another thru Push Button. The scrolling time for each display parameters for minimum of 10 secs..

- i) Cumulative active Energy (kWh) for each calendar month for previous Six months.
- ii) Cumulative apparent energy (kVAh) for each calendar month for previous Six months
- iii) Maximum demand (MD) in apparent for last billing month
- iv) Maximum demand (MD) in apparent for current month
- v) Tamper Data :
  - a) Present status of Tamper
  - b) Date & time of last tamper occurrence & tamper identification.
  - c) Date & time of last tamper removal.
  - d) Cumulative tamper occurrence count.

#### **3.5 LOAD SURVEY CAPABILITY & BILLING POINT REQUIREMENTS**

Meter shall have load survey capabilities as per table 28 of IS 15959.

The predefined date and time for registering the billing parameters of kWh, kVAh, PF and kVA MD as well as Tamper Count and Power-On hours readings shall be 00.00 hours of the first day of each calendar (billing) month. All billing parameters shall be transferred to billing registers and shall be displayed on auto cyclic display mode referred to as "BILLING PARAMETERS".

### **3.6 INTERFACE BETWEEN METER AND CMRI**

The interface between a meter and CMRI shall be with a flexible cable of adequate length having suitable female connector. This cable shall be supplied along with meter. **TAMPER & FRAUD PROTECTION**

The meter registration shall be immune to reversal in current direction. The meter shall have following anti-tamper features and shall record forward under the following conditions:

- a) Potential failure: The meter shall be capable of detecting and recording occurrences and restoration of potential failure (one phase/two phases) which can happen due to intentional / accidental disconnection of potential leads. The meter should also record event as a potential failure, when one phase line fuse failure from the main side.
- b) Current Circuit Bypass: The meter shall be capable of detecting and recording occurrences and restoration of CT circuit bypass.
- c) Current Circuit Open: The meter shall be capable of detecting and recording occurrences and restoration of opening of any one or two phases of current circuit which can happen due to intentional / accidental disconnection of current circuits. No load condition should record in meter memory as a Current circuit open event.
- d) Current Unbalance: The meter shall be capable of detecting and recording occurrences and restoration of current unbalance as an event. The above information should be possible to download from the meter through hand held unit and available at BCS end. The current unbalance more than 30 % should be recorded as an event in the meter memory.
- e) Voltage Unbalance: The meter shall be capable of detecting and recording occurrences and restoration of voltage unbalance as an event. The voltage unbalance more than 30 % should be recorded as an event in the meter memory.
- f) The meter shall comply to influence of external magnetic field (AC Electro Magnet or DC Magnet) as per IS 14697.

All types of abnormality event with date and time shall be available in the meter memory on first-in, first-out basis as per IS 15959. It shall be possible to retrieve the event data along-with all related snapshots' data through the meter's optical port with the help of a CMRI and download the same to the BCS where it shall be available for viewing. All this information shall be available in simple and easily understandable format.

### **3.7 NON INFLAMMABILITY**

The terminal block, the terminal cover and the case shall ensure reasonable safety against spread of fire. They shall not be ignited by thermic over load of live parts in contact with them. To comply with this these parts shall fulfill the conditions of the glow wire test as per IS 14697.

### **3.8 CONSTRUCTIONAL REQUIREMENTS**

Meters shall be designed and constructed in such a way so as to avoid causing any danger during use and under normal conditions. The following should be ensured:-



- i. Personal safety against electric shock
- ii. Protection against spread of fire.
- iii. Protection against effects of excessive temperature.
- iv. Protection against penetration of solid objects, dust & water
- v. Protection against fraudulence
- vi. Protection against pilferage
- vii. Meter base and meter cover shall be break to open type

### **3.9 METER CASE**

The meter should be housed in a safe, high grade engineering polycarbonate meter casing of projection mounting type and is dust, vermin and moisture proof, with enclosure having degree of protection conforming to IP-51 as per IS 14697. The meter case shall seal the meter such that the internal parts of meter are accessible only after breaking the seals of meter cover.

All insulating material used in the construction of meters shall be non-hygroscopic, non-ageing and of tested quality. All parts that are likely to develop corrosion shall be effectively protected against such corrosion during operating life by providing suitable protective coating.

### **3.10 COVER**

The cover shall be transparent, made of UV stabilized polycarbonate / engineering plastic material, which would enable easy reading the display. It should not fade in course of time and become opaque causing inconvenience for reading.

The cover shall permit clear view of the register.

### **3.11 TERMINAL AND TERMINAL BLOCK**

The meter terminal block and terminal cover shall ensure safety against the spread of fire. They should not be ignited by overload of live parts in contact with them. To comply with this, these parts shall fulfill the conditions of the glow wire test as per IS 14697.

The terminal block cover shall be fixed to the meter terminal block by at least one screw. The terminal block cover shall be provided with minimum one seal.

The meter terminal block and terminal cover shall be moulded type and made of high grade non-hygroscopic, fire retardant, low tracking, reinforced poly-carbonate (not bakelite) or equivalent high grade engineering plastic which should form an extension of the meter case and have terminal holes and shall be of sufficient size to accommodate the insulation of the conductors. The terminals shall be of suitable rating to carry 150% of  $I_{max}$  and made of electro-plated (or tinned brass). Terminals shall be of adequate size so as to ensure proper tightening of the cable and shall be of replaceable type.

### **3.12 TERMINATION**

The terminals shall have suitable construction with barriers to provide firm and safe connection of current and voltage leads of stranded copper conductors or copper reducer type terminal ends (thimbles).

The manner of fixing the conductors to the terminal block shall ensure adequate and durable contact such that there is no risk of loosening or undue heating. Screw connections shall be such that the risk of

corrosion resulting from contact with any other metal part is minimized. Electrical connections shall be so designed that contact pressure is not transmitted through insulating material. The meter shall have a design life of 10 years against design defects. The Manufacturer shall stand 24months Guarantee from date of installation on the meter against any kind of failure/defects/mal-operation within above period. Meter shall be replaced by manufacturer free of cost within two months of intimation by owner / Employer.

### **3.13 CONNECTION DIAGRAM**

Each meter shall be indelibly marked with a connection diagram which shall be provided on the terminal block cover. In case any special precautions need to be taken at the time of testing the meter, the same may be indicated along with circuit diagram. The meter terminals shall also be marked and this marking should appear in the above diagram.

### **3.14 TERMINAL ARRANGEMENT**

Three phase: The terminal arrangement and connection diagram shall be marked in accordance with clause 7.2 of IS 14697. Terminal arrangement shall be in sequence : Ir(in), Vr, Ir(out), Iy(in), Vy, Iy(out), Ib(in), Vb, Ib (out), Neutral (in), Vn, Neutral(out)

### **3.15 SEALING OF METER**

Reliable sealing arrangement should be provided to make the meter tamper evidence and avoid fiddling or tampering by unauthorized persons by way of providing adequate no. of seals on meter, meter terminal cover, wherever necessary. All the seals shall be provided in front side only. Rear side sealing arrangement will not be acceptable.

The manufacturer shall provide minimum two seals for the meter at the factory after calibration and testing. The meter cover shall have provision for placing minimum two nos. additional seals by the Employer. The manual switch and the terminal block cover shall be provided with minimum one seal each.

The holes for sealing wire shall be minimum 2 mm dia.

### **3.16 ELECTRO-MAGNETIC COMPATIBILITY AND INTERFERENCE**

The meter shall remain un-influenced with EMI/EMC interference. The meter shall withstand impulse voltage test of 6 kV as per IS 14697-1999. It shall also withstand ac high voltage test as per IS 14697.

### **3.17 TESTS**

**3.17.1** Routine & Acceptance Tests : All routine & acceptance tests shall be carried out as stipulated in IS 14697.

#### **3.17.2 Type Tests**

Energy Meters offered shall be fully type tested as per IS 14697 & IS 15959 with latest amendments at any of the NABL accredited test laboratories.

Type test certificate shall not be older than 3 years from the date of bid submission. Bid shall not be accepted without valid type test certificate.

**4.0 SINGLE PHASE, TWO WIRE, ACCURACY CLASS 0.5, ENERGY METER FOR SINGLE PHASE DISTRIBUTION TRANSFORMER**

**4.1 CT EQUIREMENT**

The Meter shall be supplied with C.T with primary current capacity required for its intended use.

**4.2** Since the meters are to be used with external CT of suitable ratio please refer CT specification provided separately. **DISPLAY**

The Single phase meters shall be capable to measure & display parameters as given below. The meter should have provision for automatic recording of cumulative kWh at 24 hrs on the last day of the month for each calendar month and same should go to memory.

The digitally measured and processed value shall be displayed through LCD having minimum six digits to read upto one-tenth of kWh. The minimum character height shall not be less than 7 mm.

The Meter should have appropriate facilities to be read in absence of Power Supply.

**4.3 AUTO SCROLL DISPLAY**

- i) Cumulative kWh
- ii) Instantaneous Voltage
- iii) Instantaneous Current
- iv) CumulativekVAh
- v) Instantaneous pf
- vi) Power on hours

**4.4 DISPLAY PARAMETERS (PUSH BUTTON)**

The display of following parameters shall be continuously scrolling one after another thru Push Button. The scrolling time for each display parameters for minimum of 10 secs.

- i) Cumulative active Energy (kWh) for each calendar month for previous Six months.
- ii) Cumulative apparent energy (kVAh) for each calendar month for previous Six months
- iii) Instantaneous voltage, current, frequency, load in kW
- iv) Maximum demand (MD) in active & apparent for last billing month
- v) Maximum demand (MD) in active & apparent for current month
- vi) Tamper Data :
  - a. Present status of Tamper
  - b. Date & time of last tamper occurrence & tamper identification.
  - c. Date & time of last tamper removal.
  - d. Cumulative tamper occurrence count.

**4.5 LOAD SURVEY CAPABILITY & BILLING POINT REQUIREMENTS**

Following load survey parameters for 35 days for 30 minute shall be logged:

- Active energy
- Apparent energy
- Voltage

The predefined date and time for registering the billing parameters of kWh, kVAh, PF and kVA MD as well as Power-On hours readings shall be 00.00 hours of the first day of each calendar (billing) month. All billing parameters shall be transferred to billing registers and shall be displayed on auto cyclic display mode referred to as "BILLING PARAMETERS".

In addition meter should have facility for daily profile for active and apparent energy.

#### **4.6 INTERFACE BETWEEN METER AND CMRI**

The interface between a meter and CMRI shall be with a flexible cable of adequate length having suitable female connector.

#### **4.7 TAMPER & FRAUD PROTECTION**

The meter shall be capable of recording correctly in following anti-tamper condition:

- i. The meter shall be capable of recording energy correctly even if input and output terminals are interchanged. Also the meter shall record correctly even if phase and neutral are interchanged.
- ii. The registration must occur whether input phase/neutral wires are connected properly or they are interchanged at the input terminals.
- iii. Performance of the meter should comply to IS 14697/CBIP report 325 under influence of external DC/AC magnetic field..
- iv. The meter shall withstand phase-to-phase voltage between phase and neutral terminals for at least 30 minutes.

Minimum one hundred fifty (100) events (including occurrence & restoration) of all types of abnormality event with date and time shall be available in the meter memory on first-in, first-out basis. It shall be possible to retrieve the event data along-with all related snap- shots' data through the meter's optical port with the help of a CMRI and download the same to the BCS where it shall be available for viewing. All this information shall be available in simple and easily understandable format.

#### **4.8 SELF DIAGNOSTIC FEATURES**

The contractor shall provide details of self-diagnostics features available and indication on the single phase meter for unsatisfactory / non-functioning of the following:

- i) Time and date
- ii) Real time clock battery
- iii) Non Volatile memory

#### **4.9 NON INFLAMMABILITY**

The terminal block, the terminal cover and the case shall ensure reasonable safety against spread of fire. They shall not be ignited by thermic over load of live parts in contact with them. To comply with this these parts shall fulfill the conditions of the glow wire test as per IS 14697.

#### **4.10 CONSTRUCTIONAL REQUIREMENTS**

**4.10.1** Meters shall be designed and constructed in such a way so as to avoid causing any danger during use and under normal conditions. However, the following should be ensured:-

- i. Personal safety against electric shock
- ii. Protection against spread of fire

- iii. Protection against penetration of solid objects, dust & water
- iv. Protection against fraudulence
- v. Protection against pilferage
- vi. Meter base and meter cover should be ultrasonically welded

#### **4.10.2 Meter Case:**

The meter should be housed in a safe, high grade engineering polycarbonate meter casing of projection mounting type and is dust, vermin and moisture proof, with enclosure having degree of protection conforming to IP-51. The meter case shall seal the meter such that the internal parts of meter are accessible only after breaking the seals of meter cover. The meter case shall have provision with deep cut for hanging the meter.

All insulating material used in the construction of meters shall be non-hygroscopic, non-ageing and of tested quality. All parts that are likely to develop corrosion shall be effectively protected against such corrosion during operating life by providing suitable protective coating

#### **4.10.3 COVER:**

The cover shall be transparent, made of UV stabilized polycarbonate material, which would enable easy reading the display. It should not fade in course of time and become opaque causing inconvenience for reading.

The cover shall permit clear view of the register.

#### **4.11 TERMINAL AND TERMINAL BLOCK**

The meter terminal block and terminal cover shall ensure safety against the spread of fire. They should not be ignited by overload of live parts in contact with them. To comply with this, these parts shall fulfill the conditions of the glow wire test as per IS 14697.

The terminal block cover shall be fixed to the meter terminal block by at least one screw. The terminal block cover shall be provided with minimum one seal.

The meter terminal block and terminal block cover shall be moulded type and made of high grade non-hygroscopic, fire retardant, low tracking, reinforced poly-carbonate (not bakelite) or equivalent high grade engineering plastic which should form an extension of the meter case and have terminal holes and shall be of sufficient size to accommodate the insulation of the conductors.

The terminals shall be of suitable rating to carry 150% of  $I_{max}$  and made of tin/nickel plated brass. Terminals shall be of adequate size so as to ensure proper tightening of the cable..

#### **4.12 TERMINATION**

The terminals shall have suitable construction with barriers to provide firm and safe connection of current and voltage leads of stranded copper conductors or copper reducer type terminal ends (thimbles).

The manner of fixing the conductors to the terminal block shall ensure adequate and durable contact such that there is no risk of loosening or undue heating. Screw connections shall be such that the risk of corrosion resulting from contact with any other metal part is minimized. Electrical connections shall be so designed that contact pressure is not transmitted through insulating material.

#### **4.13 CONNECTION DIAGRAM**

Each meter shall be indelibly marked with a connection diagram which shall be provided on the terminal block cover. The meter terminals shall also be marked and this marking should appear in the above diagram.

#### **4.14 TERMINAL ARRANGEMENT**

Single phase: Connecting terminals of current and voltage shall be in following sequence: Phase (in), Neutral (in), Neutral (out), phase (out).

#### **4.15 SEALING OF METER**

Reliable sealing arrangement should be provided to make the meter tamper evidence and avoid fiddling or tampering by unauthorized persons by way of providing adequate no. of seals on meter, meter terminal cover, wherever necessary. All the seals shall be provided in front side only. Rear side sealing arrangement will not be acceptable.

The manufacturer shall provide minimum one seal for the meter at the factory after calibration and testing. The meter cover shall have provision for placing minimum one additional seal by the Employer. The Terminal block cover shall be provided with minimum one seal.

The holes for sealing wire shall be minimum 2 mm dia.

#### **4.16 ELECTRO-MAGNETIC COMPATIBILITY AND INTERFERENCE**

The meter shall remain un-influenced with EMI/EMC interference. The meter shall withstand impulse voltage test of 6 kV as per IS 14697-1999. It shall also withstand ac high voltage test **as per above IS.**

#### **4.17 TESTS**

**4.17.1 Routine & Acceptance Tests:** All routine tests shall be carried out and acceptance tests as stipulated in IS: 14697.

##### **4.17.2 Type Tests**

Energy Meters offered shall be fully type tested as per IS 14697 with latest amendments at any of the NABL accredited test laboratories.

Bid shall not be accepted without valid type test certificate.

**5.0 SINGLE PHASE WHOLE CURRENT STATIC ENERGY METER OF CLASS 1.0 FOR CONSUMER****5.1 SCOPE**

The static whole current meter shall offer current range of -5-30A, 10-60A (first digit indicates the Basic Current & second digit indicates the Maximum Current of the respective meters) for tariff purposes, as per requirement given in this specification.

**5.2 Running at no load**

When voltage at 115% of  $V_{ref}$  is applied and no current flows in the current circuit, the test output of the meter shall not produce more than one pulse.

**GENERAL & CONSTRUCTIONAL REQUIREMENTS**

**5.2.1** Meter Shall bear BIS mark

**5.2.2** Meters shall be designed and constructed in such a way so as to avoid causing any danger during use and under normal conditions. However, the following should be ensured:-

- a) Personal safety against electric shock
- b) Personal safety against effects of excessive temperature
- c) Protection against spread of fire
- d) Protection against penetration of solid objects, dust & water
- e) Protection against fraudulence
- f) Protection against pilferage
- g) Meter base and meter cover break open type

The accuracy of the meter shall not be affected with the application of abnormal voltage / frequency generating device such as spark discharge of minimum 35 kV. The meter shall be tested by feeding the output of the device to meter in any of the following manner for 10 minutes.

1. On any of the phase or neutral terminals.
2. On any connecting wires of the meter (Voltage discharge with 0-10 mm spark gap).
3. At any place in load circuit.

The accuracy of the meter shall be checked before and after the application of above device.

**5.2.3** The meter shall be designed with latest technology and shall be manufactured using SMT (Surface Mount Technology) components. Power supply and voltage divider circuits may be of PTH Technology. The meter shall be housed in a safe, high grade engineering plastic/polycarbonate meter block casing and which is of projection mounting type and is dust/moisture proof, conforming to IP-51.

**5.2.4** All insulating material used in the construction of meters shall be on-hygroscopic, non-ageing and of tested quality. All parts that are likely to develop corrosion shall be effectively protected against corrosion throughout during operating life by providing suitable protective coating.

**5.2.5** The meter shall have an operation indication device such as a blinking LED. The operation indicator shall be visible from the front window and capable of being monitored conveniently with suitable testing equipment.

**5.2.6** The meter shall conform to the degree of protection IP 51 as per IS:12063 for protection against ingress of dust, moisture and vermins.

- 5.2.7** The meter shall be supplied with a terminal block cover. The meter terminal block and terminal cover shall be made of high grade, fire resistant, reinforced, non-flammable, polycarbonate or equivalent high grade and good quality engineering plastic.
- 5.2.8** The meter terminal block and terminal block cover shall ensure safety against the spread of fire. They should not be ignited by thermic overload of live parts in contact with them.
- 5.2.9** The meter block shall be of transparent, high grade engineering plastic for easy reading of all the displayed values/parameters, name plate details and observation of operation indicator. The transparency of the box shall remain un-influenced with the environmental conditions.
- 5.2.10** The terminal block shall be made of high grade non-hygroscopic, fire retardant, low tracking, fire resistant, reinforced poly-carbonate (not bakelite) or equivalent high grade engineering plastic which should form an extension of the meter case and have terminal holes and shall be of sufficient size to accommodate the insulation of the conductors, meeting the requirement of IS 13779: 1999.
- 5.2.11** The terminals shall have suitable construction with barriers to provide firm and safe connection of current and voltage leads of stranded copper conductors or copper reducer type terminal ends (thimbles).
- 5.2.12** The manner of fixing the conductors to the terminal block shall ensure adequate and durable contact such that there is no risk of loosening or undue heating. Screw connections transmitting contact force and screw fixing which may be loosened and tightened several times during the life of the meter shall be such that the risk of corrosion resulting from contact with any other metal part is minimized. Electrical connections shall be so designed that contact pressure is not transmitted through insulating material. The internal diameter of the terminal holes shall be 5.5 mm for 5-30A and 8.5mm for 10-60A meter. The clearance and creepage distance shall conform to relevant clause of IS 13779:1999.
- 5.2.13** The meter shall be compact in design. The meter block unit shall be capable of withstanding stresses likely to occur in actual service and rough handling during transportation. The meter shall be convenient to transport and immune to shock and vibration during transportation and handling.
- 5.2.14** The meter shall have minimum two fixing holes. The top hole shall be provided at the back of the meter so that holding screw is not accessible to the consumer after fixing the meters. The lower fixing screws shall be provided under the sealed terminal cover. The requisite fixing screws shall be supplied with each meter.
- 5.2.15** The meter shall be provided with adequate protection against damage by high current/short circuit current.
- 5.2.16** The meter shall work satisfactory as per IS 13779 under presence of various influencing conditions like external Magnetic Field, Electromagnetic Field, Radio Frequency Interference, Vibrations, harmonic Distortion, Voltage/Frequency Fluctuations, electromagnetic High Frequency Fields etc. The meter shall be capable of recording even in case of application by fraudulent means any of the tempering methods. The Meter shall have following anti-tamper features :
- i.** The meter shall be capable of recording energy correctly even if input and output terminals are interchanged. Also the meter shall record correctly even if phase and neutral are interchanged.
  - ii.** The meter shall register energy correctly even when the load is not terminated back to the meter and instead current is drawn through a local earth under the conditions:-
    - a)** When phase and neutral are connected correctly.
    - b)** When phase and neutral wires are interchanged at the input terminals.



- iii. The registration must occur whether input phase/neutral wires are connected properly or they are interchanged at the input terminals.
- iv. Performance of the meter should not be affected under influence of external DC/AC magnetic field of high intensity as mentioned in IS 13779/CBIP report 325.
- v. The meter shall be factory calibrated and shall be sealed suitably before dispatch.
- vi. The meter shall withstand phase-to-phase voltage between phase and neutral terminals for at least 30 minutes.
- vii. The Meter shall record even when the Neutral is removed or opened from both ends (source & load) and when phase and Neutral are interchanged. When neutral is removed meter should start recording energy for current of 1 amp and above.
- viii. The meter shall be able to log in the memory in case the meter cover is opened.

The meter shall be capable of recording the following tamper events in memory (minimum 5 each) with date and time stamp along with snapshots of V, I, PF and Kwh as per IS 15959.

- Neutral Missing
- Magnet Tamper (if applicable)
- Cover open tamper (occurrence only)

### **5.3 SEALING OF METER**

All meter shall be sealed by the manufacturer at its works. In addition to the seal provided by the manufacturer at its works, reliable sealing arrangement should be provided to make the meter tamper evidence and avoid fiddling or tampering by unauthorized persons by way of providing adequate no. of seals on meter, meter terminal cover, wherever necessary. The meter cover shall be sealable to the meter base with at least 2 nos. seals. Also terminal cover shall have provision for sealing with at least one seal. All the seals shall be provided in front side only. Rear side sealing arrangement will not be acceptable. Please refer Annexure- for specification for sealing system.

### **5.4 DISPLAY**

- 5.4.1** The measured value(s) shall be displayed on a Liquid Crystal display (LCD) register. The height of the digit shall be minimum 7 mm. The KWh energy registration shall take place with 6 complete digits. The display shall have backlit capability for easy reading.
- 5.4.2** The data should be stored in non-volatile memory (NVM). The non-volatile memory should retain data for a period of not less than 10 years under un-powered condition. Battery back-up memory will not be considered as NVM.
- 5.4.3** The register shall be able to record and display starting from zero, for a minimum of 1500 hours, the energy corresponding to rated maximum current at reference voltage and unity power factor. The register should not roll over in between this duration.
- 5.4.4** In addition to providing serial number of the meter on the display plate, the meter serial number shall also be programmed into meter memory for identification through communication port for CMRI/meter reading print out.

## 5.5 DISPLAY SEQUENCE

The meter shall display the required parameters in two different modes as follows:

Apart from this in case of cover open the same shall be displayed on the meter.

### A) Auto Display Mode:

The following parameters hereinafter referred to as "Billing Parameters" (B.P) shall be displayed in an auto-cycle mode, in the following sequence:-

1. LCD Test
2. Real Time
3. Date
4. Cumulative Active energy (forwarded) reading (kWh)
5. Last Bill Active Forwarded energy
6. Instantaneous Load (KW)
7. Last Bill Maximum demand (kW)

Each parameter shall be on meter display for 10 seconds.

### B) Push Button Mode:-

In addition to the auto display mode parameters, the following parameters shall be displayed on pressing the push button

1. LCD Test
2. Real Time
3. Date
4. Instantaneous voltage, current
5. Maximum demand kW for Current month
6. Supply Frequency
7. Instantaneous PF

The meter shall also be capable of offering a high resolution display which shall enable conducting of dial testing by the user in the shortest possible time and as a minimum, the meter shall be capable of offering a resolution of 4 digits after decimal (and 2 digits before decimal) for the high resolution KWh display.

## 5.6 MAXIMUM DEMAND REGISTRATION & RESET

Meter shall continuously monitor & calculate the average maximum demand for each demand interval time of 30 minutes and maximum of these in a calendar month shall be stored along with date and time when it occurred. The maximum demand shall automatically reset at 24:00 hrs. of the last date of each calendar month for which minimum 30 years calendar shall be programmed by the manufacturer.

The integration period by default shall be set as 30 minutes and programmable as per IS 15959.

The billing purpose parameters (active forwarded energy, maximum demand in kW) shall be registered and shall be available for a minimum period of atleast 6 month.

#### **5.7 LOAD PROFILE RECORDING**

The meter shall be capable of monitoring and recording load profile information for KW demand for every 30 minutes interval for at least 35 days duration. The load profile shall be configurable as per IS 15959.

#### **5.8 SELF DIAGNOSTIC FEATURE**

The meter shall be capable of performing complete self-diagnostic check to monitor integrity of data memory location at all time. The meter shall have indication for unsatisfactory /nonfunctioning /malfunctioning of the following:

- a) Time and date on meter display
- b) All display segments on meter display
- c) Real Time Clock (RTC) status in meter reading prints out at BCS end

#### **5.9 CMRI/BCS REQUIREMENTS**

The communication protocol of the meter shall be as per IS 15959 with latest amendment. The Common Meter Reading Instrument (CMRI) should be capable of being loaded with user friendly software (MS-DOS 5.0 or higher version compatible) for reading/downloading meter data. Windows based Base Computer Software (BCS) shall be provided for receiving data from CMRI and downloading instructions from base computer software to CMRI.

This BCS should have, amongst other requirements, features and facilities described later in this specification, the facility to convert meter reading data into user definable xml file format so that it may be possible for the user to integrate the same with the user's billing data and process the selected data in desired manner. All the data available in the meter including energy, MD, and history data should be convertible to user defined xml file format for integration with third party software. The vendor shall supply necessary base computer software for reading / viewing of meter data and converting to user defined xml files formats. The user shall have the flexibility to select the parameters to be converted into xml file. The vendor shall also supply the necessary CMRI software.

#### **5.10 DISPLAY POWER UP IN ABSENCE OF MAINS SUPPLY**

The meter shall have the provision of providing the display of billing parameters in absence of main supply through internal battery..

#### **5.11 CONNECTION DIAGRAM & TERMINAL MARKINGS**

The connection diagram of the meter shall be clearly shown on the meter. The meter terminals shall also be marked and this marking should appear in the above diagram.

#### **5.12 ELECTRO-MAGNETIC COMPATIBILITY AND INTERFERENCE**

The meter shall remain un-influenced with EMI/EMC interference. The meter shall withstand impulse voltage test of 6 kV as per IS 13779-1999.

### **5.13 TESTS**

Unless specifically waived off all acceptance tests shall be witnessed by the Employer.

#### **5.13.1 Type Tests**

Energy Meters offered shall be fully type tested as per IS 13779& IS 15959 with latest amendments at any of the NABL accredited test laboratories.

Type test certificate shall not be older than 3 years from the date of bid submission. Bid shall not be accepted without valid type test certificate.

#### **5.13.2 Acceptance Test**

Acceptance test shall be carried out as per IS 13779.

#### **5.13.3 Routine Tests**

All routine tests as per IS 13779 shall be carried out.

**Annexure-A**

**SPECIFICATION OF POLY CARBONATE SEALS REQUIRED FOR SEALING OF SINGLE / POLY PHASE METERS**

- 1.01** Seal should be made of polycarbonate & should not be affected by boiling water & acid.
- 1.02** The seal should withstand temperature up to 147 ° C.
- 1.03** Seal should be available in Clear / Red / Blue / Yellow / Amber / Green / Grey colour and should be transparent.
- 1.04** Every seal should have 6" long, 20 gauge, twisted strand stainless steel wire.
- 1.05** Seal should have facility to print mono gram / name of company
- 1.06** Every Seals should have a unique seven-digit number. Numbers shall be printed on seal including the anchor cap-using laser marking which shall not be erased using any tool or by any chemical reaction. Both the seven digit seal numbers should be visible separately after closing the seal.
- 1.07** Seals should have tamper proof, internal " anchor " locking mechanism that permanently secures the wire upon closing. The mechanism should be designed in such a way that its original position can't be restored after any effort of tamper or breaking of seals
- 1.08** Sealing mechanism shall be designed in such a way that it can be sealed without using any pliers or tools.
- 1.09** Seal should be constructed of two parts, first the main body (female type) & second the anchor (male type) having locking mechanism. Both the part should be designed in such a way that once the seal is closed the two parts can't be separated.
- 1.010** Seal should be patented. Copy of patent shall be submitted along with offer.
- 1.011** Packaging: Seals shall be supplied in packet of 100 seals. Each packet shall be labelled for following information
- Client Name
  - Purchase order number & date
  - Serial number range in the form of bar coding.
- 1.012** Seals shall be provided with tracking & recording software. The software shall have following features
- Software should have facility of defining the system controller
  - Facility to enter serial number of seals with the help of bar code scanner.
  - Receiving of seal in the system and with authentication like signature.
  - Facility to identify the concern who is responsible for receiving of seals and nominated by system supervisor.
  - Provision to define different type of seals for various uses.
  - Software should have facility of report generation for inventory & issue records.
  - Facility to track for relevant data for individual seal entered in the system.

**Annexure-B****TECHNICAL SPECIFICATION FOR COMMON METER READING INSTRUMENT (CMRI)**

This specification covers supply and delivery of Common Meter Reading Instrument (CMRI) for reading (uploading) the data of different make of meters and to have a capability to dump (download) the same to the base computer system. The CMRI shall have memory / space to reside software of reading at least 3 different makes of electronic meters as specified by Employer.

**A. Portable Common Meter Reading Instrument (CMRI)**

These shall be tailor-made for tapping all data stored in the memory of electronic meters of type, three phase 3 wire, three phase 3 wire HT/LT Tri-vector meters, whole current meters, single phase meter, and faithfully transferring it to the local PC in the BCS. Each device shall be supplied complete with

- i) a lead with optical head for coupling it to the meter,
- ii) a lead for plugging it to a personal computer;
- iii) an internal battery for powering the devices;
- iv) a case for safely carrying it about
- v) a battery charger

The total arrangement shall be such that one (1) operator can carry out the whole operation himself, in about five (5) minutes per meter.

- B.** The CMRI shall have a key for starting the data tapping from the coupled meter's memory, a key to start data transfer to the PC, and a lamp, which would light up on completion of data collection, remain 'on' while the data is held in the device and would go 'off' when all data has been transferred to the PC. Data tapping operation shall not erase the data from the meter's memory, or effect the meter operation in any way. The memory of the CMRI shall get automatically cleared when the data has been transferred to the PC only then the CMRI shall accept data from another meter. CMRIs shall also have the necessary provision for meter clock correction. CMRIs should have adequate memory, to host application software, for enabling downloading of meter data of 3 makes of meters.
- C.** The Contractor shall provide the necessary software which would enable a local IBM-Compatible PC to (i) accept the data from the CMRI and store it in its memory, (ii) display the collected data on PC's screen, with forward/backward rolling, (iii) print out the data collected from one or more meters, starting from a certain date and time, as per operator's instructions, (iv) transmit the collected data through an appropriate communication link to the central computer, starting from a certain date and time, as per operator's instructions, and (v) store the collected data on a floppy disc.
- D.** The above software shall further ensure that absolutely no tampering (except total erasures) of the collected metering data is possible during its handling by the PC. The software shall be suitable for the commonly available PCs, and shall be supplied to SEB in a compatible form to enable its easy loading into the PCs available (or to be installed by the SEB) at the various substations/ locations in the circle.
- E.** CMRI should be compatible with Low Power Radio module to be provided by the bidder for receiving the data from the meter to the CMRI/Hand Held UNIT and ultimately transferring to BCS & vice versa for loading required instructions to the meters.

- F.** CMRI should conform to CBIP Technical Report No. 111 with latest amendments with Level (2) IP 67 protection and following climatic condition & standards

**1.0 Standards**

The CMRI shall conform in all respects to the following standards.

- i)** CBIP Technical Report no. 111 – Specification for common Meter reading Instrument.
- ii)** IEC – 529 – Degree of Protection provided by enclosures
- iii)** IS : 12063 : 1987 – Classification of Degree of Protection provided by enclosures of electrical items
- iv)** IS 9000: 1979 – Basic environmental testing procedure for electronic & electronic items.
- v)** IEC – 1000 – Electromagnetic compatibility
- vi)** IEC – 1000-4-2 : 1995 – Electrostatic discharge immunity test
- vii)** IEC – 1000-4-3 : 195 – Radiated, radio – frequency electromagnetic field immunity test, Magnetic immunity test
- viii)** CISPAR 22 – Limits and method of measurement of radio disturbance characteristics of information technology equipment.

**2.0 Climatic Conditions:**

The detail climatic condition is specified in Section-I.

**3.0 Principal Parameter**

For downloading data from electronic meters of type, single phase, 230 V, whole current, three phase 415 V Whole current, three phase 415 V, CT operated, 33kV, 11kV, HT Trivector CT, PT operated meters. The offered meter reading device should be portable, compact and battery powered. Its memory shall be adequate to enabling transfer of data from three makes of meters equipped with suitable communication port and transferring them on to a base computer system such as an IBM compatible PC or an external peripheral & vice-versa.

The offered CMRI should have capacity compatible to read minimum 20 meters for billing & tamper data but without load survey and minimum 10 meters for billing and tamper data with load survey.

CMRI shall be able to display phase / vector diagram of phase current, phase voltage with respective phase angles and phase sequence of voltage at SITE when these data are read from the meter.

**4.0 GENERAL TECHNICAL REQUIREMENT:**

Physical Characteristics:

- i.** Size:

CMRI should be handy, lightweight and small in size for ease of portability.

- ii.** Enclosure:

CMRI casing shall be of electrical insulating material of high thermal stability and mechanical strength. Its degree of protection conforms to IP 67 LEVEL (2) as per IS 12063 / IEC-529. The enclosure should be solvent resistant and shall be provided with a suitable holding Strap for proper gripping.

- iii. Ruggedness: CMRI is able to withstand harsh field environment without physical damage or loss of data.
- iv. Display: The display of CMRI is having the following characteristics.
  - a) Easy readability in varying ambient light conditions.
  - b) 4 lines and 20 characters per line on the screen
  - c) The size of the character shall be 4 mm
  - d) The contrast and intensity control to get a clear display in varying ambient light.
- v. Key Board: The keyboard of the CMRI is having the following attributes.
  - a) Long operation life i.e. minimum 100000 operations (typical).
  - b) Feedback for key press acknowledgement to user.
  - c) Legible and non-fading keypad imprints for all alphanumeric characters/symbols.
  - d) Each English alphabet shall have a separate key.
- vi. Input / Output ports (I/O Ports) :

The CMRI shall be having two serial input/output Ports, one port shall be serial port RS 232C compatible. Another optional port can be used for convenience of connecting peripherals such as bar-code reader, printer, battery charger, loader charger etc.

The offered CMRI shall be able to provide power supply for optical sensor used for meter reading applications.

## **5.0 Physical interface:**

zInterface between meter and CMRI:

The interface between a meter and CMRI shall consist of 2 parts.

- a) Meter optical sensor terminating in to a 9 pin D type male connector with a cable of 500 mm +/- 10 mm. Length.
- b) The interface between a meter and the offered CMRI shall be with a flexible shielded cable of length 1500mm +/-10mm having 9 pin D-type female connector with electrical circuit. This cable shall be supplied along with CMRI. The two ends of the cable is stress relieved.

Interface between CMRI and Base computer station:

Suitable flexible shielded cable of sufficient length for communication between CMRI and base computer station shall be provided. This communication shall be serial RS232C. On the base computer station end of the cable a 9 pin D-type female connector shall be provided. The two ends of the cable are stress relieved.

This cable shall also be supplied along with the CMRI.

## **6.0 Hardware and Software requirement:**

- i. Operating system :



To facilitate use of various meters, specific MRI programs in one CMRI, MS DOS version 5.0 or higher system shall be used. The facility to upgrade the BIOS/OS by a CMRI manufacturer shall be available without exposing the hardware of the CMRI.

The additional program necessary to transfer application programs with serial port shall be provided.

ii. Memory:

- a) The CMRI shall be having a minimum memory capacity of 3 MB Static RAM (SRAM) with battery backup and upgradeable.
- b) BIOS/OS on FLASH memory / EEPROM MEMORY

iii. Communication:

The CMRI shall be able to communicate for-

- a) Down loading / up loading data from / to the meter
- b) Uploading / downloading data to / from the Base computer station
- c) CMRI shall be capable to read bar code information using a bar code scanner from barcodes of ac static \ electromechanical electricity meters by using appropriate scanner and bar code software.
- d) CMRI shall support flexible baud rate ranging from 300 Baud to 19200 (or higher) Baud rates to cater communication needs stated above.

iv. Real time clock :

A real time clock is provided in the CMRI, which have the following features:

Power requirement: The clock shall have a minimum of 15 days battery backup.

Calendar: The clock shall have 20 years calendar.

Time drift: The time drift shall be negligible and shall not exceed 20 seconds per day.

v. Time Setting Facility:

The CMRI shall have the facility to get its time set from Base computer station. Proper security for this is ensured using password

vi. Power supply (Battery) for CMRI:

**The CMRI shall have the following features for its power requirements:**

- a) The CMRI shall be powered by rechargeable battery housed within its enclosure.
- b) The average capacity of charged battery shall be sufficient to communicate with meters and base computer station for at least :
  - i) 6 hours while communicating through optical interface of meters and
  - ii) 8 hours without powering Input / Output ports for optical interface.

- c) To reduce the equipment down time and inventories, there shall be provision to charge the CMRI battery without being removed from the equipment. A suitable battery charger for charging of CMRI battery shall be provided.
- d) There would be a provision for AUTO POWER SAVE, which force the instrument in the power saving mode in case of no activity within 5 minutes.
- e) The battery used for data retention in SRAM would have a minimum of 3 years backup capacity.
- f) The CMRI would have battery low indication and automatic cutoff to avoid further drain of the battery.

## **7.0 Communication Protocol and Software**

Software:

- a) The following software shall be provided in the offered CMRI.
  - i) Operating system compatible to MS DOS 5.0 or (latest versionver 7.0).
  - ii) Necessary software for loading application programs via a serial port for uploading and down loading between CMRI and Base computer Station (BCS)
- b)
  - i. Provision for loading the software into the CMRI of the specific makes of the meters, for the purpose of reading and programming of the specific make(s) of static meters, such Software shall be provided by respective meter manufacturers.
  - ii. BCS software accepting data from CMRI, processing generating reports and downloading instruction from BCS to CMRI.
- c) Special Requirement:

The offered CMRI shall have provision for storing the third party software and can also be loaded for special applications such as manual meter reading, data entry through keyboard of CMRI, printing, display of balance memory etc.
- d) The CMRI shall have facility to draw/display vector diagram of the electrical conditions existing at site to check the healthiness of the connections.
- e) The CMRI shall have provision to read the energy registers so that accuracy testing can be done at site with standards calibrating equipments.
- f) The CMRI shall have the provision to read the various instantaneous electrical parameters at site like voltages, current, PF, phase angles, power (kW, KVA, and KVA) frequency etc.
- g) The CMRI shall have facility to estimate the memory space available before reading the meter.

## **8.0 DATA SECURITY**

The meter manufacturers are responsible for maintaining the security of the data extracted from the meters using manufacturer specific algorithm in the software up to down loading to BCS.

- 9.0** CMRI shall be type tested as per clause 5 of CBIP Technical Report No. 111.

**10.0 Acceptance Tests for CMRI and PC Software**

All CMRI after final assembly and before dispatch from Bidder's/Manufacturer's works shall be duly tested to verify that they are suitable for supply to the Employer. In particular, each and every CMRI shall be subjected to the following acceptance test:

- (i) Functional Checks
- (ii) Downloading Meter Data from the Meter(s)
- (iii) Compatibility with PC software
- (iv) Downloading the meter data on PC
- (v) Functioning of advance and retard time commands
- (vi) Per meter downloading time verification
- (vii) Capacity of CMRI for data storage

**35 Earthing Coil**

Earthing Coils shall be fabricated from soft GI Wire Hot Dip Galvanized. The Hot Dip galvanized wire shall have clean surface and shall be free from paint enamel or any other poor conducting material. The coil shall be made as per REC constructions standard (Refer tender drawing No. REC-XI Plan-Gen-005). The Hot Dip galvanizing shall conform to IS:2629/1966, 2633/1972 and 4826/1969 with latest amendments. Galvanizing should be heavily coated and should stand for the following tests.

**Galvanizing Tests**

- i) Minimum Mass of Zinc
  - a) ON GI Wire used 280 gm/m<sup>2</sup>
  - b) After Coiling – 266 gm/m<sup>2</sup>. The certificate from recognized laboratory shall be submitted towards mass of zinc.
- ii) Dip Test Shall stand 3 dips of 1 minute and one dip of ½ minute before coiling and 43 dips of 1 minute after coiling as per IS : 4826/1979.

**THE DIMENSIONAL REQUIREMENT SHALL BE AS FOLLOWS**

- a) Nominal dia of GI Wire 4 mm (Tolerance  $\pm$  2.5%)
- b) Minimum no. of turns – 115 Nos.
- c) External dia of Coil (Min) – 50 mm
- d) Length of Coil (Min) – 460 mm
- e) Free length of GI Wire at one end coil (Min.) – 2500 mm

The turns should be closely bound. Weight of one finished Earthing Coils (min.) – 1.850 Kg.

Adhesion test – As per ISS 4826 – 1979.

**36 Earthing Conductors**

All conductors buried in earth and concrete and above ground level shall be galvanised steel. Galvanised steel shall be subject to four one minute dips in copper sulphate solution as per IS:2633.

**37 Deep Drawn Metal Meter Box (MMB) for Single Phase Energy Meter.****1. SCOPE**

This specification covers the design, manufacture, testing at manufacturer's place, pre-dispatch inspection and supply of MS sheet, Deep Drawn Metal Meter Box (MMBs). MMBs shall be used for housing Single phase energy meter for electric connections.

**2. CONSTRUCTIONAL AND TECHNICAL PARTICULARS**

- 2.1 The Deep Drawn Metal Meter Box (MMBs) shall conform to drawings attached. It shall be for housing Single Phase energy meter of any make. The internal dimensions of MMB shall be 285mmx200mmx150mm (i.e. height x width x depth).
- 2.2 The MMB shall be made from 20 SWG MS sheet by Deep Drawn Method. The base and cover of the MMB shall be individually in one piece without any welding except for fixing of the accessories like hinges, clamps, handle etc. which shall be spot-welded. The cover of MMB shall be fixed on two-tamper proof inside hinges not visible from outside. The hinge pin diameter should be 3mm. Hinges shall be made from 1.6mm MS sheet. The pin of hinges shall have head on top so that it does not fall down after wear & tear. The door of MMB shall open from right to left by minimum 90°. The collar of the door (cover) in closed position shall rest on the collar of body (Base) of MMB. The collar of the door shall overlap the collar of the body of MMB by minimum 8mm. The collar of the body shall be provided with good quality rubber gasket lining of min. 3mm thickness. Thickness of rubber lining shall be such that it provides proper sealing between the cover & base of MMB to avoid penetration of dust & ingress of water. Rubber lining should be fixed with the best quality adhesive so that the same does not get removed by itself on opening of the door. Two numbers 'U' shaped latch arrangement shall be provided to seal the cover with base as shown in the drawing. 2.5mm & 8mm diameter hole shall be provided in U-shaped latch for sealing wires & padlock. U-latch shall be joined with stainless steel rivet. Holes provided for sealing & padlock should be aligned when latch is in closed position. 'U' shaped latch arrangement shall be made from 1.6 mm thick MS sheet and shall be welded from inner side of the box.
- 2.3 A viewing window opening of the size 90mmx100mm as indicated in the drawing shall be provided about 40mm below top edge of MMB to facilitate taking of meter readings. Viewing window shall be provided with toughened glass of 5mm thickness. This glass shall be fixed from inside of the cover of MMB, with powder coated single piece drawn metal frame (Glass Holder) made of 20 SWG MS sheet fixed with min. four welded studs & nuts. Glass holder studs & nuts shall be inside the cover so that it can not be opened from outside. Glass holder shall have rectangular cuttings as per details shown in drawing. The size of toughened glass shall be 110mmx120mm. This glass has to be filled with a wrap around single piece rubber ring without joint having minimum depth of 8mm made from good quality rubber so that it can withstand weather effect.
- 2.4 A handle of minimum 70mm length and 10mm width and 20 SWG sheet thicknesses should be provided for opening and closing of the cover at the place as shown in the drawing.
- 2.5 The mounting arrangement of the meter shall be as shown in the drawing. It should be raised from the base of MMB body by 15mm (minimum). Zinc Plated adjustable strip shall be provided on meter mounting arrangement for fixing of the meter. The supplier shall supply three mounting MS screws, one for upper (M4 threads x length 12mm) & two (M4 threads x 25mm length) in moving slotted strip.
- 2.6 Two Nos. fixing holes of 6.5mm diameter at the back of surface of MMB shall be provided to fix the MMB at flat wall. For fixing of MMB on wall, 2 Nos. Plastic fixing plugs of 50mm length and 2 Nos. 5mm diameter 40mm long pan head self tapping screws and washers shall be provided with every MMB.

- 2.7 2 Nos. holes with superior quality rubber cable glands shall be provided at the bottom of MMB. Glands shall be properly fixed such that the same does not get removed from the box. Internal diameter for incoming/outgoing gland shall be suitable for 2Cx10mm<sup>2</sup> Aluminum conductor PVC cable. Glands shall be made such that internal diameter of glands provided for cables should be closed with the film of minimum 1mm thickness. Cable will go through the glands by piercing the film of the glands. Overlapping of glands from outer side should be approximately 5mm, such that the gland is not removed when cable is inserted inside the box.
- 2.8 Louvers for ventilation shall be provided on the sidewalls of the box as shown in drawing. 20SWG perforated sheet shall be welded from inside of the louvers.
- 2.9 MMB shall be adequately protected against rust, dust, water and corrosion both from inside and outside. The MMB shall have Light Admiralty Grey shade (IS-5:1993 Colour No. 697) on outside & inside. The MMB shall be powder coated. The surface of the MMB shall be properly pre-treated and cleaned in 7 tank process and shall be applied with a powder coating of about 40 micron thickness on outer side and inside. The facility for 7-Tank Phosphating & powder coating shall be in house of the tenderer / MMB manufacturer to ensure proper quality.
- 2.10 Earthing screw of diameter M6 threads with washer shall be provided in the threads of L-shape clamp welded to main body on left side. There should be no powder coating on earthing screws. Earth marking shall be duly embossed near the earth clamp.
- 2.11 All the screws, studs and washers shall be properly Zinc Plated. The tolerance permissible on the overall dimensions shall be (±) 3%. Danger marking shall be provided on the box in red color. Utility and Manufacturer name shall be provided on the door of meter box. Each box shall be supplied with proper packing in 3ply- corrugated box.
3. The box shall comply with the requirement of IP-33. The box shall be fully type tested along with dimensional drawing as per requirement of IS 13947 (Part-1):1993 and latest amendment, from the govt.-approved laboratories. Government approved laboratories should be accredited by the National Board of Testing & Calibration Laboratories (NABL) of Govt. of India. Test certificate (not older than 5 years) shall be submitted.

#### **4. ACCEPTANCE TESTS:**

Following acceptance tests shall be carried out at manufacturer's premises during the inspection of material before dispatch:

**a) Visual Examination:**

The MMB will be inspected visually, externally and internally for proper Powder Coating layer, fitting of all the components in accordance with technical Specification.

**b) Verification of dimensions:**

Verification of dimensions, external / internal clearances will be carried out as per technical specifications.

**c) Verification of fittings:**

Components like Glass, 'U' shaped latch arrangement, glands, clamps, hinges etc will be verified as per technical specification and usage requirement.

**d) Painting:**

Deep Drawn, 7-Tank Phosphating & Powder coating facilities shall be verified at the place of inspection.

**38 Three Phase 4 Wire L.T. Distribution Box for Aerial Bunched Conductor****1 SCOPE:**

- 1.1 The L.T. Distribution Box shall be used for connection through overhead conductors or ABC line and for giving connections to the consumers. This specification covers the design, manufacture, inspection, testing and supply of L.T. Distribution Box. The L.T. Distribution Box will be installed at the Poles and it shall withstand solar radiations, rain, wind pressure and pollution.

**2 CONSTRUCTIONAL AND TECHNICAL PARTICULARS:**

- 2.1 The Distribution Box shall be made from 20 SWG CRCA MS sheet by **Deep Drawn Method with Powder Coating**. Size of the box shall be 418mm x 300mm x 120mm as shown in drawing. There shall not be any welding joint to make base and cover of the Distribution box. Roof of the box shall be tapered on both sides to drain the rain water.
- 2.2 Distribution box shall have Insulated Multiple Outgoing Connectors for R, Y, B Phases and Neutral. Distribution box shall have arrangement for one incoming cable of three phase of size up to 4core 35mm<sup>2</sup>. Arrangement for four outgoing cables of size up to 4core 16mm<sup>2</sup> for three phase connection shall be provided in the distribution box. Each Incoming & outgoing cable shall be fixed inside the connection terminals by two screws of size not less than M8. The connection terminals shall be such that the outgoing cables can be fixed or removed easily without disconnecting the power supply. No current carrying part shall be approachable by hand or finger. Any current carrying part should be at a minimum distance of 5mm from the outer edge of the insulation. Insulation shall be Fire retardant.
- 2.3 Connection terminals for R, Y, and B Phases shall be mounted horizontally in a single line and Neutral shall be mounted parallel to R, Y, and B Phases in stepped pattern. Mounting arrangement shall be such that minimum clearance of 40mm is maintained between each phase and neutral. Fixing of connection terminals with the distribution box shall be preferably non-removable type to avoid theft of connection terminals.
- 2.4 Box shall be provided with U-latch sealing arrangement. A hole of 8mm & 2.5mm shall be provided in the U-latch to provide a padlock & sealing of the box respectively. U-latch shall be joined with stainless steel rivet. Box should be duly powder coated after 7-tank Phosphating process. Box should be of Light Admiralty Grey color (IS-5:1993, COLOUR NO-697). The L.T. Distribution box shall be powder coated only. The facility for 7-Tank Phosphating and powder coating shall be in-house of the tenderer to ensure proper quality, since these boxes are for outdoor applications.
- 2.5 4 Holes for incoming cables and 4 Nos. holes for outgoing cables shall be provided on the lower wall of the box. Cable holes shall be provided with rubber / plastic glands duly pasted with the box. Incoming and outgoing cable gland shall have internal diameter of 20mm. Cable Glands shall be made such that internal diameter of glands provided for cables should be closed with the film of minimum 1mm thickness. Cable will go through the cable glands by piercing the film of the glands. Gap of minimum 100mm shall be maintained between the lower wall and neutral mounted inside the distribution box for easy handling of incoming and outgoing cables.
- 2.6 **MARKING:** Following shall be provided on the cover of box.
- Manufacturers name duly embossed
  - Utility name duly embossed
  - Name of scheme duly embossed
  - Danger marking in red color.
- 2.7 M.S. Earthing Screw of diameter 6mm with washer shall be provided in the threads of the earth clamp welded to the main body of the box.

- 2.8 The box shall comply with the requirement of IP54. The box shall be fully type tested along with dimensional details as per the requirement of relevant Indian Standard (latest edition) IS13947: Part-I and latest amendments. Tests shall be carried out from laboratories which are accredited by the National Board of Testing & Calibration Laboratories (NABL) of Govt. of India to prove that the complete box meet the requirement of IP54. The tests report shall be submitted along with the tender failing which the tender of the firm shall not be opened. Government approved laboratories should be accredited by the National Board of Testing & Calibration Laboratories (NABL) of Govt. of India. The type test reports shall not be older than 5 years.
- 2.9 Distribution Box shall be duly packed in 3Ply corrugated box. The tolerance permissible on the overall dimensions of the MMB shall be ( $\pm$ ) 3%.

### 3.0 TESTS:

Following tests shall be performed on the box during inspection:

- 3.1 **Visual Examination:**  
The L.T. Distribution box will be inspected visually, externally and internally for proper Powder Coating layer, fitting of all the components in accordance with technical Specification.
- 3.2 **Verification of dimensions:**  
Verification of dimensions, external / internal clearances will be carried out as per technical specifications.
- 3.3 **Verification of fittings:** Components like insulated connection terminals, screws etc will be verified as per technical specification.
- 3.4 **High voltage withstand test at 2.5KV:**  
The A.C. voltage of 2.5KV, 50HZ shall be applied for one minute as follows:  
a) Between each Phase  
b) Between each Phase and earth screw  
c) On the insulation of connection terminals  
There shall not be any puncture or flash over during this test.
- 3.5 **Current Carrying Capacity:** The Current of 200 AMP shall be applied for 30 minutes through high current source on the each Phase. There shall not be overheating of the terminals during this test.



**39 Deep Drawn Metal Meter Box (MMB) for Three Phase Energy Meter****1. SCOPE**

This specification covers the design, manufacture, testing at manufacturer's place, pre-dispatch inspection by Employer and supply of MS sheet, Deep Drawn Metal Meter Box (MMBs). MMBs shall be used for housing Three phase energy meter for electric connections of General category i.e. Domestic & Commercial connections.

**2. CONSTRUCTIONAL AND TECHNICAL PARTICULARS**

- 2.12 The Deep Drawn Metal Meter Box (MMBs) shall conform to drawings attached. It shall be for housing Three Phase energy meter of any make. The internal dimensions of MMB shall be 400mmx300mmx160mm (i.e. height x width x depth).
- 2.13 The MMB shall be made from 20 SWG MS sheet by Deep Drawn Method. The base and cover of the MMB shall be individually in one piece without any welding except for fixing of the accessories like hinges, clamps, handle etc. which shall be spot-welded. The cover of MMB shall be fixed on two-tamper proof inside hinges not visible from outside. The hinge pin diameter should be 3mm. Hinges shall be made from 1.6mm MS sheet. The pin of hinges shall have head on top so that it does not fall down after wear & tear. The door of MMB shall open from right to left by minimum 90°. The collar of the door (cover) in closed position shall rest on the collar of body (Base) of MMB. The collar of the door shall overlap the collar of the body of MMB by minimum 8mm. The collar of the body shall be provided with good quality rubber gasket lining of min. 3mm thickness. Thickness of rubber lining shall be such that it provides proper sealing between the cover & base of MMB to avoid penetration of dust & ingress of water. Rubber lining should be fixed with the best quality adhesive so that the same does not get removed by itself on opening of the door. Two numbers 'U' shaped latch arrangement shall be provided to Seal the cover with base as shown in the drawing. 2.5mm & 8mm diameter hole shall be provided in U-shaped latch for sealing wires & padlock. U-latch shall be joined with stainless steel rivet. Holes provided for sealing & padlock should be aligned when latch is in closed position. 'U' shaped latch arrangement shall be made from 1.6 mm thick MS sheet and shall be welded from inner side of the box.
- 2.14 A viewing window opening of the size 90mmx100mm as indicated in the drawing shall be provided about 50mm below top edge of MMB to facilitate taking of meter readings. Viewing window shall be provided with toughened glass of 5mm thickness. This glass shall be fixed from inside of the cover of MMB, with powder coated single piece drawn metal frame (Glass Holder) made of 20 SWG MS sheet fixed with min. four welded studs & nuts. Glass holder studs & nuts shall be inside the cover so that it cannot be opened from outside. Glass holder shall have rectangular cuttings as per details shown in drawing. The size of toughened glass shall be 110mmx120mm. This glass has to be filled with a wraparound single piece rubber ring without joint having minimum depth of 8mm made from good quality rubber so that it can withstand weather effect.
- 2.15 A handle of minimum 70mm length and 10mm width and 20 SWG sheet thicknesses should be provided for opening and closing of the cover at the place as shown in the drawing.
- 2.16 The mounting arrangement of the meter shall be as shown in the drawing. It should be raised from the base of MMB body by 15mm (minimum). Zinc Plated adjustable strip shall be provided on meter mounting arrangement for fixing of the meter. The supplier shall supply three mounting MS screws, one for upper (M4 threads x length 12mm) & two (M4 threads x 35mm length) in moving slotted strip.
- 2.17 Four Nos. fixing holes of 6.5mm diameter at the back of surface of MMB shall be provided to fix the MMB at flat wall. For fixing of MMB on wall, 4 Nos. Plastic fixing plugs of 50mm length and 4 Nos. 5mm diameter 40mm long pan head self-taping screws and washers shall be provided with every MMB.
- 2.18 2 Nos. holes with superior quality rubber cable glands shall be provided at the bottom of MMB. Glands shall be properly fixed such that the same does not get removed from the box. Internal diameter for incoming/outgoing gland shall be suitable for 4Cx25mm<sup>2</sup> Aluminum conductor PVC cable. Glands shall

be made such that internal diameter of glands provided for cables should be closed with the film of minimum 1mm thickness. Cable will go through the glands by piercing the film of the glands. Overlapping of glands from outer side should be approximately 5mm, such that the gland is not removed when cable is inserted inside the box.

- 2.19 Louvers for ventilation shall be provided on the sidewalls of the box as shown in drawing. 20SWG perforated sheet shall be welded from inside of the louvers.
- 2.20 MMB shall be adequately protected against rust, dust, water and corrosion both from inside and outside. The MMB shall have Light Admiralty Grey shade (IS-5:1993 Colour No. 697) on outside & inside. The MMB shall be powder coated. The surface of the MMB shall be properly pre-treated and cleaned in 7-tank process and shall be applied with a powder coating of about 40 micron thickness on outer side and inside. The facility for 7-Tank Phosphating & powder coating shall be in house of the tenderer / MMB manufacturer to ensure proper quality.
- 2.21 Earthing screw of diameter M6 threads with washer shall be provided in the threads of L-shape clamp welded to main body on left side. There should be no powder coating on earthing screws. Earth marking shall be duly embossed near the earth clamp.
- 2.22 All the screws, studs and washers shall be properly Zinc Plated. The tolerance permissible on the overall dimensions shall be ( $\pm$ ) 3%. Danger marking shall be provided on the box in red color. Utility name shall be provided on the door of meter box.
- 2.23 Each box shall be supplied with proper packing in 3ply- corrugated box.
- 3.** The box shall comply with the requirement of IP-33. The box shall be fully type tested along with dimensional drawing as per requirement of IS 13947 (Part-1):1993 with latest amendment, from the govt.-approved laboratories. Government approved laboratories should be accredited by the National Board of Testing & Calibration Laboratories (NABL) of Govt. of India.
- 4. ACCEPTANCE TESTS:**  
Following acceptance tests shall be carried out at manufacturer's premises during the inspection of material before dispatch:
- a) Visual Examination:**  
The MMB will be inspected visually, externally and internally for proper Powder Coating layer, fitting of all the components in accordance with technical Specification.
- b) Verification of dimensions:**  
Verification of dimensions, external / internal clearances will be carried out as per technical specifications.
- c) Verification of fittings:**  
Components like Glass, 'U' shaped latch arrangement, glands, clamps, hinges etc will be verified as per technical specification and usage requirement.
- d) Verification of Deep Drawn Facility, 7-Tank Phosphating, Powder Coating Process:**  
Deep Drawn, 7-Tank Phosphating & Powder coating facilities shall be verified at the place of inspection.

**40 Single Phase L.T. Distribution Box for Aerial Bunched Conductor****1 SCOPE:**

The LT Distribution box for ABC single phase is used for Connection through overhead conductors or ABC line and for giving connections to the consumers. This specification covers the design, manufacture, inspection, testing and supply of the LT Distribution box. The LT Distribution box suited for ABC single phase cable will be installed at the Poles and it shall withstand solar radiations, rain, wind pressure and pollution.

**2 CONSTRUCTIONAL AND TECHNICAL PARTICULARS:**

2.1 The Distribution Box shall be made from 20 SWG CRCA MS sheet by **Deep Drawn Method with Powder Coating**. Internal size of the box shall be 225mm x 285mm x 120mm as shown in drawing. There shall not be any welding joint to make base and cover of the Distribution Box. Roof of the box shall be tapered on both sides to drain the rain water.

2.2 Distribution Box shall have insulated Multiple Outgoing Connector for Phase and Neutral. Each Multiple Outgoing Connector shall have arrangement for one incoming cable of Single phase of size up to 25mm<sup>2</sup> and 8 outgoing cables of single phase of size up to 2core 10mm<sup>2</sup>. Each Incoming & outgoing cable shall be fixed inside the Multiple Outgoing Connector by two screws of size not less than M6. The Multiple Outgoing connector shall be such that the outgoing cables can be fixed or removed easily without disconnecting the power supply. No current carrying part shall be approachable by hand or finger. Any current carrying part should be at a minimum distance of 5mm from the outer edge of the insulation. Insulation shall be Fire retardant.

2.3 Multiple Outgoing Connectors shall be mounted horizontally. Mounting arrangement shall be such that minimum clearance of 40mm is maintained between phase and neutral. Fixing of Multiple Outgoing Connectors preferably shall be non-removable type to avoid theft of connectors.

2.4 Box shall be provided with U-latch sealing arrangement. A hole of 8mm & 2.5mm shall be provided in the U-latch to provide a padlock & sealing of the box respectively. U-latch shall be joined with stainless steel rivet. Box should be duly powder coated after 7-tank Phosphating process. Box should be of Light Admiralty Grey color (IS-5:1993, COLOUR NO-697). The LT Distribution box for ABC single phase shall be powder coated only. The facility for 7-Tank Phosphating and powder coating shall be in-house of the tenderer / manufacturer to ensure proper quality, since these boxes are for outdoor applications.

2.5 One Hole for incoming cable and 8 Nos. holes for outgoing cables shall be provided on the lower wall of the box. Cable holes shall be provided with rubber / plastic glands duly pasted with the box. Incoming and outgoing cable gland shall have internal diameter of 30mm & 15mm respectively. Cable Glands shall be made such that internal diameter of glands provided for cables should be closed with the film of minimum 1mm thickness. Cable will go through the cable glands by piercing the film of the glands. Gap of minimum 100mm shall be maintained between the lower wall and neutral mounted inside the Distribution Box for easy handling of incoming and outgoing cables.

2.6 **MARKING:** Following shall be provided on the cover of box.

- a) Manufacturers name duly embossed
- b) Utility name duly embossed
- c) Name of the scheme
- d) Danger marking in red color.

2.7 M.S. Earthing screw of diameter 6mm with washer shall be provided in the threads of the earth clamp welded to the main body of the box.

- 2.8 The box shall comply with the requirement of IP54. The box shall be fully type tested along with dimensional drawings as per the requirement of relevant Indian Standard (latest edition) IS13947: Part-I and latest amendments. Tests shall be carried out from laboratories which are accredited by the National Board of Testing & Calibration Laboratories (NABL) of Govt. of India to prove that the complete box meet the requirement of IP54. The tests report shall be submitted along with the tender failing which the tender of the firm shall not be opened. Government approved laboratories should be accredited by the National Board of Testing & Calibration Laboratories (NABL) of Govt. of India. The type test reports shall not be older than 5 years. In case order is placed on a firm, no change in design / manufacturer of LT Distribution box shall be allowed in supplies.
- 2.9 Box shall be duly packed in 3Ply corrugated box. The tolerance permissible on the overall dimensions shall be ( $\pm$ ) 3%.

### 3 **TESTS:**

Following tests shall be performed on the box during inspection:

#### 3.1 **Visual Examination:** -

The LT Distribution box for ABC single phase will be inspected visually, externally and internally for proper Powder Coating layer, fitting of all the components in accordance with technical Specification.

#### 3.2 **Verification of dimensions:** -

Verification of dimensions, external / internal clearances will be carried out as per technical specifications.

#### 3.3 **Verification of fittings:** -

Components like insulated Multiple Outgoing Connectors, screws etc will be verified as per technical specification.

#### 3.4 **High voltage withstand test at 2.5KV:** -

The A.C. voltage of 2.5KV, 50HZ shall be applied for one minute as follows:

- a) Between Phase & Neutral
- b) Between Phase and earth screw
- c) On the insulation of Multiple Outgoing Connectors.

There shall not be any puncture or flash over during this test.

#### 3.5 **Current Carrying Capacity:** -

The Current of 200 AMP shall be applied for 30 minutes through high current source on each Multiple Outgoing Connector. There shall not be overheating of the terminals during this test.

**41 Cubicle (Metal Box) for Housing LT AC Three Phase Four Wire, CT Operated Static Energy Meter, Modem and 4 No. Epoxy Resin Cast CTs.****1. SCOPE**

This specification covers the design, manufacture, testing, pre-dispatch inspection, supply and delivery of Cubicles (Metal Meter Boxes) with one no. LT AC Three Phase Four Wire, CT Operated Static Energy Meter, Modem and four no. Epoxy Resin Cast CTs, control cables, clamps, terminal block, etc. as required.

**2. CONSTRUCTIONAL AND TECHNICAL PARTICULARS:**

- 2.1 The Cubicles shall conform to approved drawings. It shall include LT AC, Three Phase, Four Wire, CT Operated Static Energy Meter, Modem and 4 no. Epoxy Resin Cast Ring Type CTs. The overall dimensions of the Cubicle shall be 960mmx460mmx215mm (i.e. height x width x depth). Tentative drawing is enclosed herewith Project Manager shall approve the drawings.
- 2.2 The Cubicle shall be made from 18 SWG CRCA sheet by Deep Drawn Method. The box shall consist of two separate compartments. Lower compartment shall be for housing 4 no. CTs and lower for housing of meter. A separate and independent door shall be provided for each of the upper and lower compartments with provision of locking and sealing arrangement. Each Door shall be fixed on two tamper proof inside hinges of suitable size not visible from outside. The hinge pin diameter should be minimum 3mm. Hinges shall be made from 1.6 mm MS sheet. The pin of hinges shall have head on top so that it does not fall down after wear & tear. The door of Cubicle shall open from right to left by minimum 90°. The collar of the door (cover) in closed position shall rest on the collar of body (Base) of Cubicle. The collar of the door shall overlap the collar of the body of Cubicle by minimum 8mm. The collar of the base shall be provided with good quality rubber gasket lining of min. 4mm thickness. Rubber lining shall be such that it provides proper sealing between the cover & base of Cubicle to avoid penetration of dust & ingress of water. Rubber lining should be fixed with suitable adhesive so that the same does not get removed by itself on opening of the door. Two numbers 'U' shaped latch arrangement shall be provided to Seal each cover with base as shown in the drawing. 2.5mm & 8mm diameter hole shall be provided in U-shaped latch for sealing wires & padlock. Holes provided for sealing & padlock should be aligned when latch is in closed position. 'U' shaped latch arrangement shall be made from 1.6 mm thick MS sheet and shall be welded from inner side of the box. U-Latch shall be duly riveted with stainless steel rivet.
- 2.3 A viewing window opening of the size 90mmx100mm as indicated in the drawing shall be provided about 50mm below top edge in the door of meter compartment to facilitate taking of meter readings. Viewing window shall be provided with toughened glass of 5mm thickness. This glass shall be fixed from inside of the cover of cubicle, with single piece drawn metal frame (Glass Holder) made of 20 SWG MS sheet fixed with min. fourwelded studs & nuts. Glass holder nuts shall be inside the cover so that it cannot be opened from outside. Glass holder should be powder coated and shall have rectangular cuttings as per details shown in drawing. The size of toughened glass shall be 110mmx120mm. This glass has to be fitted with a wraparound single piece rubber ring without joint having minimum depth of 8mm and made from good quality rubber so that it can withstand weather effect. Same arrangement shall be provided for the window provided for modem as shown in drawing.
- 2.4 The mounting arrangement of the CTs shall be as shown in the drawing. It should be raised from the base of Box body by 20mm. CT mounting plates fixed with 2 screws shall be provided as shown in the drawing.
- 2.5 Meter mounting arrangement shall be provided by supplier in the meter chamber for mounting of meter as shown in the drawing. It should be raised from the base of MMB body by 35mm (minimum). Galvanized/Zinc plated adjustable strip shall be provided on meter mounting arrangement for fixing of

the meter. The supplier shall supply three mounting MS screws, one for upper (M4 threads x length 12mm) & two (M4 threads x 35mm length) in moving slotted strip.

- 2.6 4 Nos. holes with superior quality rubber cable glands shall be provided on both sides of the lower compartment of the box for cable entry as per drawing. Internal diameter for incoming / outgoing gland shall be suitable for following power cable as below.

Sizes of cable with transformer capacity:

Type of DTR	approximate full load current	Sizes of cable
63	84	70
100	133	150
200	270	300
315	440	300

Similarly, 4 Nos. holes with superior quality rubber cable glands shall be provided in the Partition sheet of upper & lower compartments of the cubicle for entry of secondary wires of CTs. Internal diameter for gland used in partition sheet shall be 15mm. Glands shall be made such that internal diameter of glands provided for cables should be closed with the film of minimum 1mm thickness. Cable will go through the cable glands by piercing the film of the glands. Cable glands shall be fixed with suitable adhesive so that the same does not get removed.

- 2.7 For mounting of box on pole, four holes shall be provided the back side of the box as shown in drawing.
- 2.8 Louvers for ventilation shall be provided on both the sidewalls of the box as shown in drawing. 20SWG perforated sheet shall be welded from inside of the louvers suitable for IP-33 protection class with perforations as shown in drawing.
- 2.9 Cubicle shall be adequately protected against rust, water and corrosion both from inside and outside. The cubicle shall have Light Admiralty Grey shade. (IS-5:1993 Colour No. 697) on outside and inside. Glass holder shall also have Light Admiralty Grey shade. The surface of the MMB shall be properly pre-treated and cleaned in 7 tank process and shall be applied with a powder coating of about 40 micron thickness on outer side and inside. The facility for 7-Tank Phosphating & powder coating shall be in house of the tenderer to ensure proper quality since these boxes are for outdoor applications.
- 2.10 Two Earthing bolt of M8 and 25mm long shall be welded from inside of the box and shall be provided on the side wall with 2 nuts & washer. Earth marking shall be duly embossed near the earth bolts. There shall be no powder coating on the Earthing bolts.
- 2.11 All the screws, studs and washers shall be properly zinc plated.
- 2.12 The tolerance permissible on the overall dimensions shall be (±) 3%.
- 2.13 Danger marking shall be provided on the box in red color.
- 2.14 Name of Utility and name of the scheme name shall be embossed on the door of the box.
- 2.15 Each box shall be supplied with proper packing in 3ply- corrugated box.

- 3.** Genral technical detail of L.T. current transformer for use in connection with L.T. C.T. operated energy metering are as follows:

- i. C.T. shall conform to IS:2705/1992 or its latest version thereof.
- ii. Current transformer should be resin cast, ring type construction. Construction shall be single phase single core type. The internal diameters of the C.T. shall be approved by employer.
- iii. CT current ration shall be approved by Project Manager.
- iv. Suitable mounting robust clamp as per manufacturer design shall be provided.
- v. Secondary terminal shall be of brass stud type. The size shall be minimum 6.0 mm dia 20 mm outside length with spring washer and double nuts.

- vi. Rated voltage shall be Single Phase 240 V line to neutral (+15% to – 30%)
- vii. Accuracy class of 0.5 as per IS.
- viii. Rated burden shall be of 5 VA.
- ix. The instrument security factor shall be less than or equal to 5.
- x. Rated short time current of 5 KA for 1 sec. Corresponding to rated dynamic peak current of 2.5 x 5 KA (peak)
- xi. The ratio, name of manufacture / monogram and year of manufacturing shall be engraved on the body of C.T. In addition name plate of anodized aluminium indicating the necessary details, year of manufacture etc. engraved on it shall be provided in such a manner that the information is clearly visible after mounting.
- xii. The secondary and primary terminals shall be clearly marked as S1 & S2.
- xiii. The bidders should submit the drawings of offered CTs.

**4. FINISHING OF DISTRIBUTION BOX:**

The surface of the box shall be properly pretreated / phosphated in 7-tank process and shall be applied with powder coating. The process facility shall be in house of the manufacturer to ensure proper quality for outdoor application.

**5. ACCEPTANCE TESTS :**

Following acceptance tests shall be carried out while inspecting lot of material offered.

**a. Visual Examination:**

The Metal Meter Box (Cubicle) shall be inspected visually, externally and internally for proper powder coating layer, fitting of all the components in accordance with the technical specifications.

**b. Verification of Dimensions:**

Verification of dimensions, external / internal clearances shall be checked as per the technical specifications.

**c. Verification of fittings:**

Components like toughened Glass, "U" shaped latch arrangement, glands, hinges, CT fixing arrangement etc shall be verified as per the technical specifications and usage requirements.

**6. TYPE TEST:**

The Metal Meter Box shall comply with the requirement of IP33. The box shall be fully type tested as per the requirement of IS 13947 (Part-1):1993 and latest amendments. The type test shall be carried out from the Govt. approved laboratories duly accredited by National Board of Testing & Calibration Laboratories (NABL) of Govt. of India. Test certificate (not older than 5 years) shall be submitted along with the tender.

**7. Prototype & Drawings:-**

The manufacturer has to manufacturer the prototype Unit for each rating as per this specification before bulk manufacturing. The manufacturer should intimate the readiness of prototype to employer. The Project Manager will inspect the prototype for approval. The manufacturer should submit the final drawings in line with this specification and prototype to employer for approval before bulk manufacturing. The approval of prototype & drawings shall be a responsibility of manufacturer/Contractor. Tentative drawing of LTCT box is enclosed herewith.

**42 Earthing**

(AS PER IS 3043-1987)

Earthing shall generally be carried out in accordance with the requirements of Indian Electricity Rules 2003 amended from time to time and relevant regulations under Electricity Supply Authority concerned.

In case of high and extra high voltages, the neutral points shall be earthed by not less than two separate distinct connections with earth, each having its own electrodes sub-station and will be earthed at any other point provided no interference is caused by such earthing. If necessary, the neutral may be earthed through suitable impedance.

As far as possible, all earth connections should be visible for inspection. Each earthing system shall be so designed, that, the testing of individual earth electrodes is possible. It is recommended that the value of any earth system resistance shall be such as to conform to the degree of shock protection desired.

It is recommended, that a drawing showing the main earth connections and earth electrodes be prepared for each installation and submitted to Employer.

No addition to the current carrying system, either temporary or permanent, shall be made which will increase the maximum available fault current on its duration until it has been ascertained that the existing arrangement of earth electrodes, earth bus-bar etc., are capable of carrying the new value of earth fault current which may be obtained by this addition.

All materials, fittings etc., used in earthing shall conform to Indian Standard Specifications, wherever they exist.

**GENERAL REQUIREMENTS AND PROCEDURES FOR EARTHING AT SUB-STATIONS.**

The ground resistance for sub-stations should not exceed a value 2(two) ohms. The joints/connections in the earthing, system shall be welded only, except the connections, which require opening for testing/maintenance. Such connections should be bolted tightly, using spring and ring washers for proper contact pressure. The G.S. flats to be provided for the horizontally laid earth grid should have overlap welded joints, with length of welding at least twice the width of the flat, e.g., 100 MM for 50x6 MM G.S. flats. There should not be any dirt, grease, oil, enamel, paint or any such non-conductive coatings on the surfaces being joined/ connected. Only the finished joints/connections above ground may be provided with red-oxide or any other protective coating. Underground earth electrodes and earth grid elements, when laid, should have a clean metallic surface, free from paint, enamel, grease or any such non-conductive coatings.

As far as possible, all earth connections should be accessible for visual inspection. No cut-outs, links or switches, other than linked switches arranged to operate simultaneously on the earthed or earthed neutral conductor and the live wire shall be inserted in the supply system. Earth electrodes or mate should not be installed in close proximity to metal fence to avoid possibility of fence becoming live. Separate earth electrodes, isolated from the earth grid, are to be provided for grounding the fence wires.

Pipes or rods used as electrodes should be in one piece, as far as possible, with a minimum allowable length of 3 mtrs. Except where rock or hard stratum is encountered, the pipe/rod electrodes should be driven into the ground to a minimum depth of 3 mtrs. The strip electrodes, forming the horizontal grid, should be buried underground to a minimum depth of 0.5 mtrs. The path of earth wire should be out of normal reach of any person, as far as possible.

For high resistivity soils, above 100 Ohm-mtrs., attempts should be made to bring the soil resistivity in the range of 50 to 60 Ohm-mtrs. By digging and treating the soil mass around the earth grid/electrodes with a mixture of salt and charcoal.



In case of rocky top soil and sub-stratum, having very high resistivity, with no scope of improvement by other means, the procedure given below should be followed:

1. At least two bores of diameter little less than 40 mm, with a minimum distance of 10 mtrs. between them, should be made in the ground at suitable locations inside the S/S yard. The boring should be done until soil sub-stratum rich in moisture and low in resistivity is encountered. G.I. pipes of 40 MM dia. should be descended in each bore, such that, the soil mass around the pipes grips them tightly, Back – filling of bores, if required, with wet soil/clay may be done to ensure this condition. The G.I. pipes in these deep bores should be interconnected with the main earthing grid of the S/S through 50x6 mm G.S. flat, with all the joints/connections and terminations being either fully welded, or clamped/bolted and welded simultaneously. The G.I. pipes in the bores should also be interconnected with each other. In extreme cases, the bores may have to be made at remote locations i.e. outside the S/S yard, with inter-connections, through 50x6 MM flats, as explained before.
2. The procedures to be observed stringently for making connections and joints between various elements of the earthing system are as follows:
  - a. G.S. flat to Structure/flat - The G.S. flat should be welded to the metallic portion (leg) of the structure after thoroughly cleaning the surfaces to be welded. The length of the welding should be at least twice the width of the G.S. flat, e.g.-minimum 100 mm for 50x6 mm G.S. flat. Exactly similar procedure is to be adopted for joints between two G.S. flats.
  - b. G.I. wire to structure. The G.I. wire should be bolted to the structure after making an eye formation and kept tight with the help of spring and ring washer. Then, the entire arrangement should be welded.
  - c. G.I. wire to G.S. flat- The G.I. wire should be bolted and then welded to G.S. flat, as explained above.
  - d. G.I. rod to G.S. flat- The G.I. rod should be securely clamped to the G.S. flat with the help of bolts and washers and the entire arrangement should then be welded.
  - e. G.I. wire to G.I. pipe – GI wire should be bolted to the G.I. pipe and then welded, keeping in view the relevant precautions, mentioned before.
  - f. G.I. flat to G.I pipe – The GI flat should be bolted tightly to the G.I. pipe and then the connection should be welded.

Before making connections and joints, it should be ensured that, the elements to be joined have a clean metallic contact surface without any non-conductive coating.

### **EARTH GRID SYSTEM**

Grid system of interconnected conductors forming a closed loop mesh is to be installed using 75x8 mm MS flat for peripheral and branch conductors. Interconnections are made by welding them. This earth grid will be laid at a depth of about 0.5 mtr. bonded to general mass of the earth by 3 mtrs. long earth electrode of solid MS rod (or pipe) of dia 25mm. The G.I. pipe 40 mm. dia 3 mtrs. long in the earthing pits, driven vertically.

It is to this earth grid that the transformer neutral, apparatus, frame work and other non-current carrying metal work associated like transformer tank, switchgear frame etc. are to be connected. All these connections should be made in such a way that reliable and good electrical connection is ensured.

Aluminum/ other paint, enamel, grease and scale should be removed from the point of contact before connections are made. No part of the ground connection leads should be embedded in concrete.

Arrangement of connection of earth connection shall be as follow:

**1. STRUCTURES:**

Structures including frames, metal supports within the substation grid at least two legs, preferably diagonally opposite (where more than two legs are provided) on each metal structure shall be connected to earth grid with GI wire of 4mm dia or 6 mm dia.

**2. ISOLATORS/ SWITCHES:**

The operating handle shall be connected to earth grid independent of the structure earthing or through the steel mounting structure, through 4 mm dia G.I. wire.

**3. LIGHTNING ARRESTOR:**

The bases of lightning arrestors shall be directly connected to the earth electrodes by 4 or 6 SWG G.I. wires as short and as straight as practicable, to ensure minimum impedance. Separate earth leads should be used for L.A. in each phase. In addition there shall be as direct connections as practicable from the earthed side of the lightning arrestors to the frame of the apparatus being protected. Surge counters, could also be inserted in the circuit where lightning incidences are high, but in such cases, the lightning arrestor should be mounted on insulated base. Invariably, earth connections for lightning arrestors should be separate, and in no case should they be joined looped or meshed with other conductors. For lightning arrestors mounted near transformers, earthing connections shall be done with the earthing pits and earthing leads shall be laid clear of the tank and collars in order to avoid possible oil leakage caused by arcing. The earth connection should not pass through iron pipes, as it would increase the reactive impedance of the connection.

**4. POWER TRANSFORMER:**

- The tank of the transformer shall be directly connected to the main earth grid. In addition there shall be a separate and as direct a connection as practicable from the tank to the earth side of protecting LA using 4 or 6 SWG GI wire.
- The earthing of the neutral shall be by two separate, distinct and direct connections of 50x6 mm GS flat to earth pits, which form a part of the earth grid, and shall be run clear of the tank and collars.
- The transformer track rails shall be connected to earth

**5. OUT DOOR VCB:**

At least two legs, preferably diagonally opposite of the supporting structure frame work of each circuit breaker unit shall be connected to the earth grid, through 50x6 mm G.S. flats.

**6. FENCING:**

Fencing and gate should be earthed separately.

**7. CURRENT TRANSFORMERS / POTENTIAL TRANSFORMERS:**

The bases of the current transformers should be directly connected to the earth grid through 4 or 6 SWG G.I. wires. The base (neural side) of the P.Ts. should be directly connected to the earth grid through 4 or 6 SWG G.I. wires. Separate earth leads should be used for P.Ts. in each phase. The termination of leads on the P.T. neutral should be bolted/clamped and not welded, to facilitate opening of the earth connection for testing purposes. In addition, all bolted cover plates to which bushings are attached, should be connected to the earth grid, both in case of C.Ts. and P.Ts.

- 8.** Armoring of armored metal-sheathed cables within the station grid area shall be connected to the earth grid.
- 9.** Substation L.T. Supply Transformer: Same as above except that the neutral earthing conductor used shall be 4 or 6 SWG G.I. wire.

**43 Gi Earthing Pipe**

Earthing pipe should be made of 40 mm diameter ISI marked B class GI Pipe. 12 mm dia suitable holes on its circumference shall be made as per approved drawing. The pipe should be in one piece. No joints or welding would be allowed on its length. Clamps made of 50x6mm GI flat duly drilled with 12 mm size holes should be welded at the top end for connection of earth conductor.

Pipe used shall be 40mm NB diameter, ISI marked Galvanized Mild Steel Tubes continuously welded Electric Resistance Welded ERW/High Frequency Induction welded (HFIW)/Hot finished welded (HFW) type, conforming to IS-554-1985 with latest amendment of MEDIUM quality (Class B).

**1. MANUFACTURE:**

GI earth pipe (40 mm diameter & 3 metre long) shall be made of tubes which shall be made from tested quality steel manufactured by any approved process as follows:

- a) Electric Resistance Welded (ERW).
- b) High Frequency Induction Welded (HFIW) and
- c) Hot finished Welded (HFW).

Tubes made by manual welding are not acceptable.

**2. DIMENSIONS:**

The dimensions and weights of tubes shall be in accordance with Table-I and Table-II of IS: 1239 (Part-I)/1990 with latest amendments, subject to tolerance permitted therein. Necessary 12 mm diameter holes across the circumference shall be provided as per approved drawing. Drawings shall be approved by the owner before start of the manufacturing work. The tube, earthing pipe shall be provided with 50x6mm GS clamps on one end, one clamp is to be welded with the pipe and another is removable to enable measurement of earth resistance of the pit. Other end of the earth pipe should be cut half in slop to make it a sharp.

**3. GALVANIZING:**

Tubes shall be galvanized in accordance with IS-4736-1986 with latest amendment for not dip zinc coating of Mild Steel Tubes. The minimum mass of zinc coating on the tubes shall be in accordance with clause 5.1 of IS-4736-1986 (specification for hot dip zinc) and when determined on a 100mm long test piece in accordance with IS: 6745:1972 shall be 400 g/m<sup>2</sup>. The zinc coating shall be uniform adherent reasonably smooth and free from such imperfections as flux, ash and dross inclusions, bare patches, black spots, pimples, lumpiness, rust, stains, bulky white deposits and blisters.

**4. HYDRAULIC TEST:**

(Before applying holes) Each tube shall withstand a test pressure of 5 M Pa maintained for at least 3 seconds without showing defects of any kind. The pressure shall be applied by approved means and maintained sufficiently long for proof and inspection. The testing apparatus shall be fitted with an accurate pressure indicator

**5. TEST ON FINISHED TUBES AND SOCKETS:**

The following tests shall be conducted by the manufacturer of finished tubes and sockets.

- a) The tensile strength of length of strip cut from selected tubes when tested in accordance with IS-1894-1972, (Method for tensile testing of steel tubes), shall be at least 320N/mm<sup>2</sup>.

- b) The elongation percentage on a gauge length of 5.65/so (where so is the original cross-sectional area of test specimen) shall not be less than 20%.
- c) When tested in accordance with IS-2329-1985 (Method for Bend test on Metallic tubes) the finished tube shall be capable of with standing the bend test without showing any sign of fracture or failure. Welded tubes shall be bent with the weld at 90 degree to the plane of bending. The tubes shall not be filled for this test.
- d) Galvanized tubes shall be capable of being bent cold without cracking of the steel, through 90 degree round a former having a radius at the bottom of the groove equal to 8 times the outside diameter of tube.
- e) Flattening Test on Tubes above 50 mm Nominal Bore: Rings not less than 40 mm in length cut from the ends of selected tubes shall be flattered between parallel plates with the weld, if any, at 90 degree (point of maximum bending) in accordance with IS-2328-1983. No opening should occur by fracture in the weld unless the distance between the plate is less than 75 percent of the original outside diameter of the pipe and no cracks or breaks in the metal elsewhere than in the weld shall occur, unless the distance between the plates is less than 60% of the original outside diameter. The test rings may have the inner and outer edges rounded.
- f) GALVANISHING TEST:
- Weight of zinc Coating: For tubes thickness upto 6 mm the minimum weight of zinc coating, when determined on a 100 mm long test piece in accordance with IS-4736-1986 shall be 400 gm/m<sup>2</sup>.
  - The weight of the coating expressed in gram/m<sup>2</sup> shall be calculated by dividing the total weight of the zinc (inside plus outside) by the total area (inside plus outside) of the coated surface.
  - Test specimen for this test shall be cut approximately 100 mm in length from opposite ends of the length of tubes selected for testing. Before cutting the test specimen, 50 mm from both ends of the samples shall be discarded.
- g) Free Bore Test: A rod 230mm long and of appropriate diameter shall be passed through relevant nominal bore of the sample tubes to ensure a free bore.
- h) Uniformity of Galvanized Coating: The galvanized coating when determined on a 100 mm long test piece [see V (a) (iii)] in accordance with IS-2633-1986 (Method for testing uniformity of coating on zinc coated articles) shall with stand 4 one minute dips.

## 6. WORKMANSHIP:

The tubes shall be cleanly finished and reasonably free from injurious defects. They shall be reasonably straight, free from cracks, surface flaws, laminations, and other defects, both internally and externally. The screw tubes and sockets shall be clean and well-cut. The ends shall be cut cleanly and square with the axis of tube.

## 7. MARKING:

The medium class of tubes shall be distinguished by Blue colour bands which shall be applied before the tubes leaves the manufacturers' works. Tubes shall be marked with the standard mark.

**44 GS Stay Sets (16 mm AND 20 mm)****1. 16MM DIA STAY SETS (GALVANIZED)**

The stay sets (Line Guy set) will consist of the following components:-

- a) **ANCHOR ROD WITH ONE WASHER AND NUT:** Overall length of rod should be 1800 mm to be made out of 16 mm dia GS Rod, one end threaded upto 40mm length with a pitch of 5 threads per cm and provided with one square GS washer of size 40x40x1.6mm and one GS hexagonal nut conforming to IS:1367:1967 & IS:1363:1967. Both washer and nut to suit threaded rod of 16mm dia. The other end of the rod to be made into a round eye having an inner dia of 40mm with best quality welding.
- b) **ANCHOR PLATE SIZE 200x200x6MM:** To be made out of GS plate of 6mm thickness. The anchor plate should have at its centre 18mm dia hole.
- c) **TURN BUCKLE & EYE BOLT WITH 2 NUTS:** To be made of 16mm dia GS Rod having an overall length of 450 mm, one end of the rod to be threaded upto 300 mm length with a pitch of 5 threads per cm and provided with two GS Hexagonal nuts of suitable size conforming to IS:1363:1967 & IS:1367:1967. The other end of rod shall be rounded into a circular eye of 40mm inner dia with proper and good quality welding.
- d) **BOW WITH WELDED ANGLE:** To be made out of 16mm dia GS rod. The finished bow shall have an overall length of 995mm and height of 450 mm, the apex or top of the bow shall be bent at an angle of 10 R. The other end shall be welded with proper and good quality welding to a GS angle 180mm long having a dimension of 50x50x6mm. The angle shall have 3 holes of 18mm dia each.
- e) **THIMBLE:** To be made on 1.5 mm thick GS sheet into a size of 75x22x40mm and shape as per standard shall be supplied.
- f) **Galvanizing:** The complete assembly shall be hot dip galvanized.
- g) **WELDING:** The minimum strength of welding provided on various components of 16mm dia stay sets shall be 3100 kg. Minimum 6 mm fillet weld or its equivalent weld area should be deposited in all positions of the job i.e. at any point of the weld length. The welding shall be conforming to relevant IS: 823/1964 or its latest amendment. Minimum length of weld to be provided at various places in the stay sets shall be indicated by the bidder. Welding if, found short in lengths as per final approved drawings shall be rejected.
- h) **THREADING:** The threads on the Anchor Rod, Eye Bolt & Nuts shall be as per specification IS: 4218:1967 (ISO Metric Screw Threads). The nuts shall be conforming to the requirement of IS: 1367:1967 & have dimensions as per IS; 163:1967. The mechanical property requirement of fasteners shall conform to property clause 4.6 each for anchor rod & Eye bolt and property clause 4 for nuts as per IS: 1367:1967.

AVERAGE WEIGHT OF FINISHED 16MM STAY SETS 7.702 KG. (MINIMUM) (EXCLUDING NUTS THIMBLES AND WASHERS) 8.445 KG. (MAXIMUM)

**2. 20 MM DIA STAYS SETS FOR 33KV LINES (GALVANIZED)**

THE STAY SET (LINE GUY SET) WILL CONSIST OF THE FOLLOWING COMPONENTS:

- a) **ANCHOR ROD WITH ONE WASHER AND NUT:** Overall length of Rod should be 1800mm to be made out of 20mm dia GS Rod, one end threaded upto 40mm length with a pitch of a threads per cm. And provided with one square G.S. Washer of Size 50x50x1.6mm and one GS Hexagonal nut conforming to IS:1367:1967 & IS:1363:1967. Both washer & nut to suit the threaded rod of 20mm. The other end of the rod to be made into a round eye having an inner dia of 40mm with best quality welding. Dimensional and other details are indicated and submitted by bidders for owner's approval before start of manufacturing.
- b) **ANCHOR PLATE:** Size 300x300x8mm: To be made out of G.S. Plate of 8mm thickness. The anchor plate to have at its centre 22mm dia hole.
- c) **TURN BUCKLE, EYE BOLT WITH 2 NUTS:** To be made of 20mm dia G.S. Rod having an overall length of 450 mm. One end of the rod to be threaded upto 300mm length with a pitch of 4 threads per cm. The 20mm dia bolt so made shall be provided with two G.S. Hexagonal nuts of suitable size conforming to IS:1637/1967 & IS:1363/1967.  
  
The other end of the rod shall be rounded into a circular eye of 40mm inner dia with proper and good quality of welding. Welding details are to be indicated by the bidder separately for approval.
- d) **BOW WITH WELDED CHANNEL:** To be made out of 16mm dia G.S. Rod. The finished bow shall have an overall length of 995 mm and height of 450 mm. The apex or top of the bow shall be bent at an angle of 10R. The other end shall be welded with proper and good quality welding to a G.S. Channel 200mm long having a dimension of 100x50x4.7 mm. The Channel shall have 2 holes of 18 mm dia and 22 dia hole at its centre.
- e) **THIMBLE 2 Nos.:** To be made of 1.5mm thick G.S. sheet into a size of 75x22x40mm and shape as per standard.
- f) **GALVANISING:** The complete assembly shall be hot dip galvanised.
- g) **WELDING:** The minimum strength of welding provided on various components of 20mm dia stay sets shall be 4900 kg. Minimum 6mm fillet weld or its equivalent weld area should be deposited in all positions of the job i.e. at any point of the weld length. The welding shall be conforming to relevant IS: 823/1964 or its latest amendment.
- h) **THREADING:** The threads on the Anchor Rods, Eye Bolts and Nuts shall be as per specification IS: 4218:1967 (ISO Metric Screw Threads). The Nuts shall be conforming to the requirements of IS: 1367:1967 and have dimension as per IS 1363:1967. The mechanical property requirement of fasteners shall conform to the properly clause 4.6 each for anchor rods and Eye bolt and property clause 4 for nuts as per IS: 1367:1967.

AVERAGE WEIGHT OF FINISHED 20MM STAYS SET: 14.523 KG. (MIN.) (EXCLUDING NUTS THIMBLE & WASHER): 15.569 KG. (MAX.)

3. **TEST CERTIFICATE:** The contractor shall be required to conduct testing of materials at Govt./Recognized testing laboratory during pre – dispatch inspection for Tensile Load of 3100 Kg/4900 Kg. applied for one minute on the welding & maintained for one minute for 16 mm and 20 mm dia stay sets respectively.
4. **IDENTIFICATION MARK:** All stay sets should carry the identification mark of word DDUGJY and size of the stay set. This should be engraved on the stay plate and on stay rods to ensure proper identification of the materials.

The nuts should be of a size compatible with threaded portion of rods and there should be no play or slippage of nuts.

Welding wherever required should be perfect and should not give way after erection.

5. **TOLERANCES:** The tolerances for various components of the stay sets are indicated below subject to the condition that the average weight of finished stay sets of 16mm dia excluding nuts, thimbles and washers shall not be less than the weight specified above :-

No. Item	Section Tolerances	Fabrication Tolerances	Material
1 Anchor Plate	6mm thick + 12.5% - 5%	200x200mm + 1%	GS plate 6mm thick
	8mm thick + 12.5% - 5%	300x300mm + 1%	GS plate 8mm thick
2 Anchor Rod	16mm dia + 5%- 3%	Length 1800mm + 0.5%	GS Round 16mm dia
		Rounded Eye 40 mm inside dia + 3%. Threading 40mm+11% - 5	GS Round 16mm dia
	20mm dia + 3%- 2%	Length 1800mm + 0.5%	GS Round 20mm dia
		Round Eye 40mm inside dia + 3%. Threading 40mm +11% -5%	GS Found 20mm dia
3 Turn Buckle Bow	16 mm dia + 5%- 3%	Length 995mm + 1% 16mm dia	GS Round 16mm dia
		Length 180mm + 1% 50x50x6mm	GS Angle
		Channel length 200mm + 1%	GS Channel 100x50x4.7mm
4 Eye Bolt Rod	16mm dia +	Length 450mm + 1%	GS Round



	5%- 3%	Threading 300mm + 1% Round Eye 40mm inside dia + 3%	16mm dia
	20mm dia + 3%- 2%	Length 450mm + 1% Threading 300mm + 1% Round Eye 40mm inside dia + 3%	GS Round 20mm dia

**45 GI Stay Wires**

**1. SCOPE**

This Specification covers details of G.I. stranded stay wires for use in rural distribution system.

**2. APPLICABLE STANDARDS**

Except when they conflict with the specific requirements of this specification, the G.I. Stranded Wires shall comply with the specific requirements of IS:2141-1979, IS:4826-1979 & IS:6594-1974 or the latest versions thereof.

**3. APPLICATION AND SIZES**

**3.1** The G.I. stranded wires covered in this Specification are intended for use on the overhead power line poles, distribution transformer structures etc.

**3.2** The G.I. stranded wires shall be of 7/2.5mm, 7/3.15mm and 7/4.0mm standard sizes.

**4. MATERIAL**

The wires shall be drawn from steel made by the open hearth basic oxygen or electric furnace process and of such quality that when drawn to the size of wire specified and coated with zinc, the finished strand and the individual wires shall be of uniform quality and have the properties and characteristics as specified in this specification. The wires shall not contain sulphur and phosphorus exceeding 0.060% each.

**5. TENSILE GRADE**

The wires shall be of tensile grade 4, having minimum tensile strength of 700 N/mm<sup>2</sup> conforming to IS:2141.

**6. GENERAL REQUIREMENTS**

**6.1** The outer wire of strands shall have a right-hand lay.

**6.2** The lay length of wire strands shall be 12 to 18 times the strand diameter.

**7. MINIMUM BREAKING LOAD**

The minimum breaking load of the wires before and after stranding shall be as follows :

No. of wires & const.	Wire dia (mm)	Min. breaking load of Single wire before stranding (KN)	Min. breaking load of the standard wire (KN)
7(6/1)	2.5	3.44	22.86
7(6/1)	3.15	5.45	36.26
7(6/1)	4.0	8.79	58.45

## **8. CONSTRUCTION**

- 8.1** The galvanised stay wire shall be of 7-wire construction. The wires shall be so stranded together that when an evenly distributed pull is applied at the ends of completed strand, each wire shall take an equal share of the pull.
- 8.2** Joints are permitted in the individual wires during stranding but such joints shall not be less than 15 metres apart in the finished strands.
- 8.3** The wire shall be circular and free from scale, irregularities, imperfection, flaws, splits and other defects.

## **9. TOLERANCES**

A tolerance of  $(\pm)2.5\%$  on the diameter of wires before stranding shall be permitted.

## **10. SAMPLING CRITERIA**

The sampling criteria shall be in accordance with IS:2141.

## **11. TESTS ON WIRES BEFORE MANUFACTURE**

The wires shall be subjected to the following tests in accordance with IS:2141.

- i) Ductility Test
- ii) Tolerance on Wire Diameter

## **12. TESTS ON COMPLETED STRAND**

The completed strand shall be tested for the following tests in accordance with IS:2141.

- a) Tensile and Elongation Test :  
 The percentage elongation of the stranded wire shall not be less than 6%.
- b) Chemical analysis
- c) Galvanising Test :  
 The Zinc Coating shall conform to "Heavy Coating" as laid down in IS:4826

## **13. MARKING**

Each coil shall carry a metallic tag, securely attached to the inner part of the coil, bearing the following information:

- a) Manufacturers' name or trade mark
- b) Lot number and coil number
- c) Size
- d) Construction
- e) Tensile Designation
- f) Lay
- g) Coating
- h) Length

- i) Mass
- j) ISI certification mark, if any

**14. PACKING**

The wires shall be supplied in 75-100 Kg. coils. The packing should be done in accordance with the provisions of IS:6594.

**46 MCCB**

The MCCBs provided in these boxes shall conform in all respects to the relevant IS: 2516 (Pt-I&II)/1977 or its latest revision as applicable.

**REQUIREMENT OF MCCBs:**

The moulded case circuit breakers should comprise of a switching mechanism, an effective extinguishing device and a tripping unit contained in a compact moulded case cover made of high strength, heat resistance and flame retardant thermo-insulating materials. They should comprise of a spring assisted quick make/quick break type independent manual trip free mechanism rendering it easy to manually operate the MCCBs and capable of clearly indicating "TRIPPED", "ON" AND "OFF" positions from the position of the operating handle. The contact tips should be made of a suitable alloy having high arc resistance and a long electrical and mechanical life needing no replacement. The breakers should be designed with a common trip bar to break and make all the three phase together even when fault occurs on any of the phases. The breakers should provide protection against sustained overloads and short circuits through thermal-magnetic/fully magnetic releases. These MCCBs along with terminal blocks are intended to be housed in the distribution boxes made out of sheet steel of 2mm gauge. The assembly of the MCCBs and the terminal blocks should be compact, reliable from operation point of view and safe to the operating personnel. As already mentioned earlier, the MCCBs should be fully maintenance free.

**TECHNICAL PARTICULARS OF MCCBs:**

The LT MCCBs should have inverse current/time characteristics suitable for protection of 63KVA, 100KVA, 200KVA & 315KVA 11.0.4KV Distribution Transformers against sustained over-loads and short circuits for following operating conditions:-

i	Rated Operating Voltage	3 Phase 415 Volts AC 50 cycles with neutral solidly grounded system
ii	Standard rated current ratings for MCCBs to be used with different sizes of transformers will be as follows:-	
a)	For 63KVA 11/0.4KV Dist. Transformer	90 Amps
b)	For 100KVA 11/0.4KV Dist. Transformer	140 Amps
c)	For 200KVA 11/0.4KV Dist. Transformer	300 Amps
d)	For 315KVA 11/0.4KV Dist. Transformer	450 Amps
iii	No. of Poles	3
iv	Duty	Un-interrupted
v	Maximum ambient temperature	47°C in shade
vi	Minimum ambient temperature	4°C in shade
vii	Average altitude	A maximum of 1000 meter
viii	Maximum humidity	Frequently approaches saturation point

**TIME/CURRENT CHARACTERISTICS:**

The circuit breakers shall have time/current characteristics suitable for following operating conditions :-

Multiple of normal current rating	Tripping time
1.1 times	After 4 hours
1.2 times	Less than 50 minutes
1.3 times	Less than 30 minutes
1.4 times	Less than 10 minutes
2.5 times	Less than 1 minute

6 times	Less than 40 mili-seconds
12 times	Less than 40 mili-seconds

Time/Current characteristic of the Circuit Breaker (MCCB) shall be tested in accordance with Clause-7.7.2.3 (b) (2) of IS:2516-(Pt-I&II) Sec.I/1977 and the test shall be made with all the three phases loaded.

For time/current characteristic, the reference calibration temperature of the MCCBs shall be 40°C and durance, if any, upto 50°C operating temperature in the enclosure shall not exceed 10% of the value indicated above in Clause (I) above.

The MCCBs shall be calibrated and adjusted in the factory itself for the desired time/current characteristic.

The MCCB should have the following maximum resetting time under overload & short circuit conditions :-

- Overload conditions - 3 minutes
- Short Circuit conditions - Instantaneous

**RATED SHORT CIRCUIT BREAKING CAPACITY:**

The rated short circuit breaking capacity of the MCCBs shall be as follows: -

Transformer rating(KVA)	Rated short circuit breaking capacity of the breaker in Kilo-Amps
63 KVA	A minimum of 3 Kilo-Amps
100 KVA	A minimum of 5 Kilo-Amps
200KVA	A minimum of 10 Kilo-Amps
315KVA	A minimum of 15 Kilo-Amps

The short circuit breaking capacity test as specified above shall be based on short circuit tests carried out at 0.4 Power Factor (lagging). For the purpose of these tests, the following operating sequence shall be followed: -

Break-3 minutes interval-Make-Break-3 minutes interval-Make-Break.

**47 H.R.C. Fuse**

The H.R.C. fuse links of 100 Amp, 200 Amp, 300 Amp ratings, should be ISI marked & conforming to ISS: 9224-1979 with latest amendment and to be supplied with suitable base of bakelite on DMC. The knife contact should be made of tinned/silver plated copper complete with extension strips. The extension strips should be made of copper. The thickness of the copper strips should be 2mm for 100 Amp and 200 Amp, 3.0mm for 300 Amp. The strips should be in one piece. The HRC Fuse units should also be supplied with suitable lugs for 3 core 95 sq.mm, 120 sqmm and 300 sq.mm. cables for 100, 200 and 300 Amps ratings respectively. The dimension of the lugs should be as under

S.No.	Ratings of HRC Fuse unit	Cable sizes	Minimum thickness of lugs Flat (mm) / Rounded (mm)	Minimum total length of lugs (mm)
1	100 Amp	95 sq.mm	4.2 / 2.1	64
2	200 Amp	120 sq.mm	4.6 / 2.3	73
3	300 Amp	300 sq.mm	7.0 / 3.5	15

The knife contact should have pressure springs to hold the fuse links. The extension strips shall be provided with GI nut & bolts and plain and spring washer to both the end. The DMC or bakelite base should be provided with suitable fixing alignment.

The following test certificates should invariably to be performed on the HRC Fuse Units.

1. Test for temperature rise at rated current
2. Current time characteristics
3. Determination of minimum fusing current and minimum non-fusing current
4. Test for duty

The breaking capacity of HRC Fuse Units should not be less than 80 KA.

The following tests shall be performed during pre-despatch inspection at manufacturer's works: -

1. Insulation resistance test
2. Temperature rise test
3. High Voltage test

Marking on the fuse base and on the fuse links :

1. Name of the manufacturer
2. Rated current
3. Rated voltage
4. ISI marking and reference of 185 No. (only on fuse links)
5. Rated Power loss
6. Name of the Employer

**48 Triple Pole Switch Fuse Units with Neutral Links  
(200A, 320A & 400A/415 VOLTS RATINGS)**

This specification covers manufacture, testing before dispatch and delivery of Triple Pole Switch Fuse Units with neutral Link and HRC cartridge type fuses suitable for AC 3 Phase 4 wire 415 V with neutral solidly grounded system. The working conditions and technical requirements are as under:-

**TECHNICAL REQUIREMENTS**

- a) Rated Current : 200 Amps, 320 Amps & 400 Amps
- b) I) Rated Operational Voltage : 3 Phase 4 Wire, 415 Volts AC 50 Hz with solidly earthed neutral
- II) Highest System Voltage : 415V + 10%
- c) Type of Fuse to be used : Non-deteriorating quick arcing type ISI marked HRC Cartridge fuse Links suitable for Class-1 category of duty of IS:13703(Part-I). The temperature rise shall be in accordance with IS:13703 (Part-I) (with latest amendments) over and above the ambient temperature of 45°C. It shall be used for protecting the distribution circuits and distribution transformers and shall be capable of carrying continuously the above stated rated current safely.
- d) Number of Poles : Three
- e) Neutral Link : One
- f) Duty : Un-interrupted duty
- g) Rated fused short circuit withstands current capacity at 415V : 40KA for 1 second.
- h) Utilization category as : AC-23 (B) as defined in IS: 13947 (Pt-III)/ 1993

**GENERAL**

**1. CONTACTS AND BLADES & OPERATING MECHANISM**

The switch shall be a combination of double break per pole AB switch with HRC fuses in all the three phases. The switch shall be spring assisted, quick make and quick break type having operating mechanism independent of the speed of the operator to minimize the arcing. If required, additional contact springs shall be provided to maintain correct contact pressures throughout operating life of the switches. The switch shall be so constructed that the alignment of its contacts & blades, which will be made of silver plated electrolytic copper/tinned copper, is maintained under asymmetrical fault conditions also. The tenders should furnish in their offers about the details of switching mechanism and the contacts. The switch shall have positive break feature such that it is possible to make it OFF even if the quick action spring fails due to ageing or other causes. The switch fuse unit shall be provided with double break per pole to ensure complete isolation of HRC Fuses from both incoming and outgoing circuits when the switch is in OFF position, in order to minimize the damage to the maintenance



personnel. Ample flash over distances shall be provided so as to make the unit suitable for controlling highly inductive loads.

**2. ENCLOSURES**

The Triple Pole Switch fuse units shall be totally enclosed in robust enclosures made out of 16 guage/1.5 mm pressed steel sheet (conforming to relevant ISS for M.S. sheet) designed to withstand humid and hot weather conditions. The enclosures should have adequate strength and rigidity to withstand rough usage without fracture or permanent distortion. Suitable mounting arrangement shall be provided on the enclosures for mounting the units on a supporting structure.

**3. INTER LOCK**

It should not be possible to open the switch cover when the switch is in 'ON' position and also it should not be possible to operate the switch 'ON' when the switch cover is open.

**4. PAINTING**

The inside and outside of the enclosure should be painted with a grey paint. Before painting the surface, the same should be chemically cleaned for removing rust, grease etc. Then it should be given phosphate coating, followed by two coats of anti-rust primer (i.e. Red zinc Chrome Primer), after which two coats of synthetic paint of light grey colour shall be applied on internal and external surfaces of the enclosures with a spray gun. The enclosures shall then be baked in oven so as to give an elegant and durable finish.

**5. EARTHING**

The enclosure shall be provided with earthing arrangements at two places.

**6. TERMINAL CONNECTIONS**

The switch shall be provided with aluminium lugs for termination of PVC coated aluminium cables of following sizes: -

S.No.	Capacity of TPN Switches	Size of Cable	No. of cable sockets required
1	200 Amps	150 sq.mm. 3.5 Core stranded aluminium cable	8 Nos. (3 Nos. phase leads and 1 natural lead for incoming and also 3 Nos. phase leads and 1 neutral for outgoing connections)
2	320 Amps	300 sq.mm. 3.5 Core stranded aluminium cable	-do-
3	400 Amps	300 sq.mm. 3.5 Core stranded aluminium cable	-do-

**7.** All the surface contacts (e.g. lugs, connectors, fixed contacts, moving contacts etc.) should be fitted with GI nuts & bolts having yellowish OR whitish passivation with good finish.

**8. TESTING & TEST CERTIFICATES FOR SWITCHES**

The performance of the switch should conform to IS:10027/1981 with latest amendments. Accordingly, certificates from reputed laboratories such as CPRI, ERDA, IITs, for the type tests in accordance with IS:10027/1981 with latest amendment would necessarily be furnished by the tenderers along with offer.

**9. USE OF ISI MARK HRC FUSES**

The HRC Fuses with ISI mark only should be used. These HRC fuses should conform to IS:13703 (Part-I)/1993 or as per its latest revision. The rated current of HRC fuses must be 200 Amps for 200 Amps Switches, 315 Amps for 320 Amps Switches and 400 Amps for 400 Amps Switches.

**10. IMPORTANT NOTE**

The firms must consider supply of 'ISI' certificate (valid on date) products on their offer in the tender, Other certification such as ISO:9001 & 9002 shall be given due weightage while considering their offer, however, the attested photo copies of such certification must be enclosed with the offer.

**11. INSULATION FOR LIVE PARTS**

All live parts shall be fully shielded with bakelite shrouds.

**49 Clamps & Connectors**

CLAMPS & CONNECTORS: Clamps & connectors shall conform to IS: 5561. The clamps and connectors shall be made of materials listed below:

For connecting ACSR conductors	Aluminium alloy casting, conforming to designation A6 of IS: 617 and shall be tested for all test as per IS: 617
For connecting equipment terminals made of copper with ACSR conductor	Bimetallic connectors made from aluminium alloy casting conforming to designation A6 of IS:617 with 2mm thick Bimetallic liner and shall be tested as per IS:617
For connecting GS shield wire	Galvanised mild steel
Bolts, Nuts & plain washers	Hot dip galvanised mild steel for sizes M12 and above, and electro-galvanised for sizes below M12
Spring washers for items 'a' to 'c'	Electro-galvanised mild steel suitable for at least service condition 4 as per IS:1573

All castings shall be free from blow holes, surface blisters, cracks and cavities. All sharp edges and corners shall be blurred and rounded off.

No current carrying part of a clamp or connector shall be less than 10 mm thick. They shall be designed and manufactured to have minimum contact resistance.

For Bimetallic clamps or connectors, copper alloy liner of minimum 2 mm thickness shall be provided.

Flexible connectors, braids or laminated strips made up of copper/ aluminium for the terminal clamps for equipment shall be suitable for both expansion or through (fixed/ sliding) type connection of IPS Aluminium tube as required. In both the cases the clamp height (top of the mounting pad to center line of the tube) should be same.

Size of the terminal/conductor for which the clamp/connector is suitable shall be embossed/punched (i.e. indelibly marked) on each components of the clamp/ connector, except on the hardware.

Clamp shall be designed to carry the same current as the conductor and the temperature rise shall be equal or less than that of the conductor at the specified ambient temperature. The rated current for which the clamp/ connector is designed with respect to the specified reference ambient temperature, shall also be indelibly marked on each component of the clamp/connector, except on the hardware.

Clamps and connector shall be designed corona controlled.

Clamps & connectors shall conform to type tests and shall be subjected to routine and acceptance tests on minimum 3 samples per lot as per IS: 5561. Type tests report for all clamps and connectors for temperature rise test, tensile test, shall be furnished by the Contractor.

**50 Epoxy Based Protective Paint**

**1. SCOPE**

This specification covers the requirement of self-priming epoxy-based protective paint both for new and old steel structures such as poles, sub-station structures etc.

**2. COMPOSITION**

The paint shall be epoxy-based with metallic zinc as an essential component. The paint shall be supplied in two components and shall be suitable for a single coat application. It shall have such composition as to satisfy the requirements of this standard. The mixing ratio (base-to-accelerator) shall be specified by the manufacturer.

**3. REQUIREMENTS**

3.1	Volume Solids	85% (±)3%
3.2	Theoretical covering Capacity	6.5 sq. mtrs. per litre at 125 microns dry film thickness
3.3	Weight per 10 litres of mixed paint	14 to 15 Kg. (±) 0.3 kg
3.4	Drying time (at 30 OC) dry	Surface : Not more than 4 hours Hard Dry : 16-18 hours Recoating Time: 16-18 hours Curing time : 7 days
3.5	Scratch hardness (with 1.5 kg.load)	No such scratch as to show the base metal
3.6	Finish	Smooth and semi-glossy
3.7	Colour	Ash Grey or Aluminium (as required)
3.8	Dry Film Thickness	The paint shall develop a dry film of minimum 100-125 microns in a single coat(measured by Elcometer)
3.9	Flash point	Not below 40 OC
3.10	Flexibility and adhesion	The paint shall not show damage, detachment or cracking.
3.11	Resistance to humidity	Shall pass 1000 hours (minimum) at 125 microns D.F.T
3.12	Resistance to lubricating oil petroleum, hydrocarbon solvent,petrol and heat	Shall show no sign of permanent injury

**4. STORAGE LIFE & POT LIFE**

4.1	Storage life	Minimum 6 months from the date of manufacture in original sealed container under normal covered storage conditions
-----	--------------	--

4.2	Pot life (at 300C)	Not less than 4 hours
-----	--------------------	-----------------------

**5. DURABILITY**

Under severe surface conditions, paint shall protect the substrate at least for 5 years, if it is wire-brushed/power tool cleaned and 7 years for commercially grit-blasted steel sub-strate.

**6. SURFACE PREPARATION**

If possible, the surface on which the paint has to be applied shall be cleaned by grit blasting, otherwise manual wire brushing or power tool cleaning process may be used as convenient.

**7. METHOD OF APPLICATION**

Brushing, rollers or spraying.

**8. TESTS**

The following tests shall be carried out in accordance with the procedure given in the Indian Standard quoted against each, except requirements stipulated in clauses 3.1 and 3.2 which shall be tested in accordance with the procedure indicated in Annexure-II; preparation of painted panels for conducting different tests shall be done as given in Annexure-I.

**8.1** Requirement stipulated in clauses 3.3 to 3.12 - **IS:101**

**8.2** **Resistance to Salt Spray**  
 Shall pass 1000 hours (minimum with 200 microns D.F.T.) - **IS:2074**

**8.3** **Chemical Resistance**  
 Shall be resistant to acid/alkaline chemicals or solvents - **IS:8662**

**9. PACKAGE**

Unless otherwise specified by the purchaser, the paint shall be normally supplied in 2 litre packs.

**Annexure – I**

**DETAILS OF PREPARATION OF PAINTED PANELS FOR TESTING EPOXY BASED  
 PROTECTIVE PAINT ( TWO PACKS)**

<b>S. N.</b>	<b>Test</b>	<b>Type of Metal</b>	<b>Size in mm</b>	<b>Painting Details</b>	<b>Dry Film Thickness</b>	<b>Method of Application</b>	<b>Duration of air drying before commencement of test</b>	<b>Special Instructions</b>
<b>1</b>	<b>2</b>	<b>3</b>	<b>4</b>	<b>5</b>	<b>6</b>	<b>7</b>	<b>8</b>	<b>9</b>
1	Drying Time	Mild Steel	150x100x1.25	One coat of Epoxy based protective paint	100	Brush /Spray	-	-
2	Finish	-do -	-do-	-do -	-do -	-do -	48 hours	
3	Colour	-do -	-do -	-do -	-do-	-do -	24 hours	
4	Dry Film Thickness	-do -	-do -	-do-	-do -	-do -	24 hours	-
5	Flexibility and adhesion	Tinned	150x150x0.315	-do -	-do-	-do-	7 days	-
6	Scratch Hardness	-do -	-do -	-do-	-do -	-do -	-do -	-
7	Resistance to Salt Spray	-do -	-do -	-do-	-do -	-do -	-do -	-
7	Protection against corrosion under conditions of condensation	Mild Steel	150x150x1.25	-do -	200	-do -	7 days	Apply a load of 1.5 Kgs. Instead of 1 kg. As specified in Col.15.1 of
8		- do -	- do -	-do-	125	- do -	- do -	IS: 101 – 64 -

**ANNEXURE-II****Procedure for determining volume solids****1. Scope :**

This method is applicable to the determination of the volume non-volatile matter of paint coatings.

**2. Significance :**

This method is intended to provide a measure of the volume of dry coating obtainable from a given volume of liquid coating. This volume is considered to be the most equitable means of comparing the coverage (square metre of surface covered at a specific film thickness per unit volume) and also for calculating the wet film thickness of the given paint.

**3. Apparatus**

- i) Analytical Balance
- ii) Steel disc : Preferably stainless steel, 60mm dia, and 0.70mm thickness with a small hole 2 to 3mm from the edge. A fine wire such as chromel is attached through the hole and made of the appropriate length for suspending the disc in a liquid.
- iii) Weight Box
- iv) Beaker : 1 litre for weighing the disc in liquid.
- v) Weight per litre cup for determining the specific gravity of the paint material and of the suspending liquid if not known.
- vi) Oven

**4. Procedure**

- i) Dry the disk in an oven at 105<sup>0</sup>C for 10 minutes and cool.
- ii) Weigh the disk in air, let it be W1 grams.
- iii) Suspend the disk in water and weigh again. Let it be W2 grams.
- iv) Calculate the volume of disk 'V' as follows:  
$$V = \frac{W1 - W2}{d}$$
where 'd' is the density of the water at room temperature
- v) Determine the weight of non-volatile content per gram of the liquid coating material by drying a known amount of paint at 105<sup>0</sup>C for 3 hours. Let it be 'W' grams.
- vi) Determine the specific gravity of the paint to the nearest 0.001 g/ml. by using weight per liter cup. Let it be 'p'.
- vii) Dip the disk in the paint sample for 10 minutes, and take out the disc and allow the excess coating material to drain off. Blot the coating material off the bottom edge of the disc so that beads or drops do not dry on the bottom edge of the disc.
- viii) Dry the disc in oven for 3 hours at 105<sup>0</sup> C and cool.
- ix) Weigh the coated disc in air. Let it be W3 grams.
- x) Suspend the coated disc in water and weigh it. Let it be W4 grams.
- xi) Calculate the volume of the coated disc as follows:

$V_1 = W_3 - W_4/d$ , where 'd' is the density of the water at room temperature.

xii) Calculate the volume of the dried coating as follows:

Volume of dried coating ( $V_d$ ) =  $V_1 - V$

xiii) Calculate the volume of the wet coating as follows:

$V_w = W_3 - W_1/W \times P$ , where W = grams of non volatile matter in one gram of wet coating

P= Specific gravity of the paint.

xiv) Calculate the percentage volume solids of the paints as follows:

$$= \frac{V_1 - V \times 100}{V_w} \quad \text{or} \quad \frac{V_d \times 100}{V_w}$$

The volume of non volatile matter or the percentage volume solids of a paint is related to the covering capacity and film thickness in the following manner:

a) Theoretical Coverage ( $m^2/l$ ) =  $\frac{\% \text{ volume solids} \times 10}{\text{Dry film thickness (in microns)}}$

b) Wet film thickness (in microns) =  $\frac{\text{Dry Film thickness} \times 100}{\text{(in microns)}}$

% volume solids.



**51 Mid Span Compression Joint and Repair Sleeve****1.0 Mid Span Compression Joint**

**1.1** Mid Span Compression Joint shall be used for joining two lengths of conductor. The joint shall have a resistivity less than 75% of the resistivity of equivalent length of conductor. The joint shall not permit slipping off, damage to or failure of the complete conductor or any part thereof at a load less than 95% of the ultimate tensile strength of the conductor.

**1.2** In ACSR conductors, the joint shall be made of steel and Aluminium for jointing the steel core and Aluminium respectively. The steel sleeve should not crack or fail during compression. The Brinell Hardness of steel sleeve shall not exceed 200. The steel sleeve shall be hot dip galvanised. The Aluminium shall have Aluminium/alloy. Aluminium plugs shall also be provided on the line of demarcation between compression and non compression zone.

**2.0 Repair Sleeve**

Repair Sleeve of compression type shall be used to repair conductor with not more than two strands broken in the outer layer. The sleeve shall be manufactured from Aluminium and shall have a smooth surface. The repair sleeve shall comprise of two pieces with a provision of seat for sliding of the keeper piece. The edges of the seat as well as the keeper piece shall be so rounded that the conductor strands are not damaged during **installation**.

**3.0 Material and Workmanship**

**3.1** All the equipment shall be of the latest proven design and conform to the best modern practices adopted in the power line field. The Supplier shall offer only such equipment as guaranteed by him to be satisfactory and suitable for 11/33 kV transmission line application and will give continued good performance.

**3.2** The design, manufacturing process and quality control of all the materials shall be such as to achieve requisite factor of safety for maximum working load, highest mobility, elimination of sharp edges and corners, best resistance to corrosion and a good finish.

**3.3** All ferrous parts shall be hot dip galvanised, after all machining has been completed. Nuts may, however, be tapped (threaded) after galvanising and the threads oiled. Spring washers shall be electro galvanised as per grade 4 of IS-1573-1970. The bolt threads shall be undercut to take care of increase in diameter due to galvanising. Galvanising shall be done in accordance with IS:2629-1985 / IS-1367 (Part-13) and satisfy the tests mentioned in IS-2633-1986. Fasteners shall withstand four dips while spring washers shall withstand three dips. Other galvanised materials shall have a minimum over range coating of Zinc equivalent to 600 gm/sq.m and shall be guaranteed to withstand at least six dips each lasting one minute under the standard Peerce test for galvanising unless otherwise specified.

**3.4** The zinc coating shall be perfectly adherent, of uniform thickness, smooth, reasonably bright, continuous and free from imperfections such as flux, ash, rust stains, bulky white deposits and blisters. The zinc used for galvanising shall be of grade Zn.99.95 as per IS:209.

**3.5** In case of castings, the same shall be free from all internal defects like shrinkage, inclusion, blow holes, cracks etc.

- 3.6** All current carrying parts shall be so designed and manufactured that contact resistance is reduced to minimum and localised heating phenomenon is averted.
- 3.7** No equipment shall have sharp ends or edges, abrasions or projections and shall not cause any damage to the conductor in any way during erection or during continuous operation which would produce high electrical and mechanical stresses in normal working. The design of adjacent metal parts and mating surfaces shall be such as to prevent corrosion of the contact surface and to maintain good electrical contact under all service conditions.
- 3.8** Particular care shall be taken during manufacture and subsequent handling to ensure smooth surface free from abrasion or cuts.
- 3.9** The fasteners shall conform to the requirements of IS:6639-1972. All fasteners and clamps shall have corona free locking arrangement to guard against vibration loosening.

#### **4.0 Compression Markings**

Die compression areas shall be clearly marked on each equipment designed for continuous die compressions and shall bear the words 'COMPRESS FIRST' suitably inscribed on each equipment where the compression begins. If the equipment is designed for intermittent die compressions, it shall bear the identification marks 'COMPRESSION ZONE' and 'NON-COMPRESSION ZONE' distinctly with arrow marks showing the direction of compression and knurling marks showing the end of the zones. The letters, number and other markings on finished equipment shall be distinct and legible.

#### **5.0 Drawings**

**5.1** The Supplier shall furnish detailed dimensioned drawings of the equipments and all component parts. Each drawing shall be identified by a drawing number and Contract number. All drawings shall be neatly arranged. All drafting and lettering shall be legible. The minimum size of lettering shall be 3 mm. All dimensions and dimensional tolerances shall be mentioned in mm.

**5.2** The drawings shall include

- (i) Dimensions and dimensional tolerances
- (ii) Material. Fabrication details including any weld details and any specified finishes and coatings. Regarding material, designations and reference of standards are to be indicated.
- (iii) Catalogue No.
- (iv) Marking
- (v) Weight of assembly
- (vi) Installation instructions
- (vii) Design installation torque for the bolt or cap screw
- (viii) Withstand torque that may be applied to the bolt or cap screw without failure of component parts
- (ix) The compression die number with recommended compression pressure.

(x) All other relevant technical details

**5.3** The above drawings shall be submitted in 3 copies with all the details as stated above along with the bid document. After the placement of award. The Contractor shall again submit the drawings in four copies to the Owner for approval. After Owner's approval and successful completion of all type tests, 10 more sets of drawings shall be submitted to Owner for further distribution and field use at Owner's end.

## **6.0 Tests**

### **6.1 Type Tests**

#### **6.1.1 Mid Span Compression Joint for Conductor**

- (a) Chemical analysis of materials ( as per Annexure – A)
- (b) Electrical resistance test
- (c) Heating cycle test
- (d) Slip strength test

#### **6.1.2 Repair Sleeve for Conductor**

- (a) Chemical analysis of materials

#### **6.1.3 Flexible Copper Bond**

- (a) Slip Strength Test ( as per Annexure – A)

### **6.2 Acceptance Tests**

#### **6.2.1 Mid Span Compression Joint for Conductor and Earthwire**

- (a) Visual examination and dimensional verification
- (b) Galvanising test
- (c) Hardness test

#### **6.2.2 Repair Sleeve for Conductor**

- (a) Visual examination and dimensional verification

#### **6.2.3 Flexible Copper Bond**

- (a) Visual examination and dimensional verification
- (b) Slip strength test

### **6.3 Routine Tests**

- (a) Visual examination and dimensional verification

### **6.4 Tests During Manufacture**

On all components as applicable

- |     |  |   |    |     |            |
|-----|--|---|----|-----|------------|
| (a) | Chemical analysis of Zinc used for galvanising   | ) |    |     |            |
|     |  | ) |    |     |            |
| (b) | Chemical analysis mechanical metallographic test and magnetic particle inspection for malleable castings | ) | As | per | Annexure-A |
|     |  | ) |    |     |            |
| (c) | Chemical analysis, hardness tests and magnetic particle inspection for forgings                          | ) |    |     |            |
|     |  | ) |    |     |            |

## **7.0 Tests and Standards**

### **7.1 Testing Expenses**

**7.1.1** Supplier shall indicate the laboratories in which they proposes to conduct the type tests. They shall ensure that adequate facilities for conducting the tests are available in the laboratory and the tests can be completed in these laboratories within the time schedule guaranteed by them in the appropriate schedule.

**7.1.2** The Contractor shall intimate the Owner about carrying out of the type tests alongwith detailed testing programme at least 3 weeks in advance of the scheduled date of testing during which the Owner will arrange to depute his representative to be present at the time of carrying out the tests.

### **8.0 Sample Batch For Type Testing**

**8.1** The Contractor shall offer material for sample selection for type testing only after getting Quality Assurance Programme approved by the Owner. The Contractor shall offer at least three times the quantity of materials required for conducting all the type tests for sample selection. The sample for type testing will be manufactured strictly in accordance with the Quality Assurance Programme approved by the Owner.

**8.2** Before sample selection for type testing the Contractor shall be required to conduct all the acceptance tests successfully in presence of Owner's representative.

### **9.0 Schedule of Testing and Additional Tests**

**9.1** The Supplier has to indicate the schedule of following activities

- (a) Submission of drawing for approval.
- (b) Submission of Quality Assurance programme for approval.
- (c) Offering of material for sample selection for type tests.
- (d) Type testing.

**9.2** The Owner reserves the right of having at his own expense any other test(s) of reasonable nature carried out at Contractor's premises, at site, or in any other place in addition to the aforesaid type, acceptance and routine tests to satisfy himself that the material comply with the specifications.

**9.3** The Owner also reserves the right to conduct all the tests mentioned in this specification at his own expense on the samples drawn from the site at Contractor's premises or at any other test centre. In case of evidence of non compliance, it shall be binding on the part of Contractor to prove the compliance of the items to the technical specifications by repeat tests, or correction of deficiencies, or replacement of defective items, all without any extra cost to the Owner.

## **10 Test Reports**

**10.1** Copies of type test reports shall be furnished in atleast six copies alongwith one original. One copy shall be returned duly certified by the Owner, only after which the commercial production of the concerned material shall start.

**10.2** Copies of acceptance test report shall be furnished in atleast six copies. One copy shall be returned, duly certified by the Owner, only after which the materials will be despatched.

**10.3** Record of routine test report shall be maintained by the Contractor at his works for periodic inspection by the Owner's representative.

**10.4** Test certificates of tests during manufacture shall be maintained by the Contractor. These shall be produced for verification as and when desired by the Owner.

## **11.0 Inspection**

**11.1** The Owner's representative shall at all times be entitled to have access to the works and all places of manufacture, where the material and/or its component parts shall be manufactured and the representatives shall have full facilities for unrestricted inspection of the Contractor's, sub-Contractor's works raw materials. manufacturer's of all the material and for conducting necessary tests as detailed herein.

**11.2** The material for final inspection shall be offered by the Contractor only under packed condition. The engineer shall select samples at random from the packed lot for carrying out acceptance tests.

**11.3** The Contractor shall keep the Owner informed in advance of the time of starting and of the progress of manufacture of material in its various stages so that arrangements could be made for inspection.

**11.4** Material shall not be despatched from its point of manufacture before it has been satisfactorily inspected and tested unless the inspection is waived off by the Owner in writing. In the latter case also the material shall be despatched only after all tests specified herein have been satisfactorily completed.

**11.5** The acceptance of any quantity of material shall in no way relieve the Contractor of his responsibility for meeting all the requirements of the Specification, and shall not prevent subsequent rejection, if such material are later found to be defective.

## **12.0 Packing and Marking**

**12.1** All material shall be packed in strong and weather resistant wooden cases/crates. The gross weight of the packing shall not normally exceed 50 Kg to avoid handling problems.

**12.2** The packing shall be of sufficient strength to withstand rough handling during transit, storage at site and subsequent handling in the field.

- 12.3** Suitable cushioning, protective padding, dunnage or spacers shall be provided to prevent damage or deformation during transit and handling.
- 12.4** Bolts, nuts, washers, cotter pins, security clips and split pins etc. shall be packed duly installed and assembled with the respective parts and suitable measures shall be used to prevent their loss.
- 12.5** Each component part shall be legibly and indelibly marked with trade mark of the manufacturer and year of manufacture.
- 12.6** All the packing cases shall be marked legibly and correctly so as to ensure safe arrival at their destination and to avoid the possibility of goods being lost or wrongly despatched on account of faulty packing and faulty or illegible markings. Each wooden case/crate shall have all the markings stencilled on it in indelible ink.
- 13.0 Standards**
- 13.1** The Hardware fittings, conductor and earthwire accessories shall conform Indian/International Standards which shall mean latest revisions, with amendments/changes adopted and published, unless specifically stated otherwise in the Specification.

## **ANNEXURE – A**

### **1.0 TESTS ON HARDWARE FITTINGS**

#### **1.1 Galvanising/Electroplating Test**

The test shall be carried out as per Clause no. 5.9 of IS:2486-(Part-1) - 1972 except that both uniformity of zinc coating and standard preece test shall be carried out and the results obtained shall satisfy the requirements of this specification.

#### **1.2 Mechanical Strength Test of Each Component**

Each component shall be subjected to a load equal to the specified minimum ultimate tensile strength (UTS) which shall be increased at a steady rate to 67% of the minimum UTS specified. The load shall be held for five minutes and then removed. The component shall then again be loaded to 50% of UTS and the load shall be further increased at a steady rate till the specified UTS and held for one minute. No fracture should occur. The applied load shall then be increased until the failing load is reached and the value recorded.

#### **1.3 Mechanical Strength Test of Welded Joint**

The welded portion of the component shall be subjected to a Load of 2000 kgs for one minute. Thereafter, it shall be subjected to die-penetration/ ultrasonic test. There shall not be any crack at the welded portion.

#### **1.4 Clamp Slip Strength Vs Torque Test for Suspension Clamp**

The suspension assembly shall be vertically suspended by means of a flexible attachment. A suitable length of Conductor shall be fixed in the clamp. The clamp slip strength at various tightening torques shall be obtained by gradually applying the load at one end of the conductor. The Clamp slip strength vs torque curve shall be drawn. The clamp slip strength at the recommended tightening torque shall be more than 12.5% but less than 20% of conductor rated strength.

## **2.0 TESTS ON CONDUCTOR AND EARTHWIRE ACCESSORIES**

### **2.1 Mid Span Compression Joint for Conductor and Earthwire**

#### **(a) Slip Strength Test**

The fitting compressed on conductor/earthwire shall not be less than one metre in length. The test shall be carried out as per IS:2121 (Part-II)- clause 6.4 except that the load shall be steadily increased to 95% of minimum ultimate tensile strength of conductor/earthwire and retained for one minute at this load. There shall be no movement of the conductor/ earthwire relative to the fittings and no failure of the fittings during this one minute period.

#### **(b) Hardness Test**

The Brinell hardness at various points on the steel sleeve of conductor core and of the earthwire compression joint and tension clamp shall be measured.

### **2.2 Flexible Copper Bond**

#### **a) Slip Strength Test**

On applying a load of 3 kN between the two ends, stranded flexible copper cable shall not come out of the connecting lugs and none of its strands shall be damaged. After the test, the lugs shall be cut open to ascertain that the gripping of cable has not been affected.

### **2.3 Chemical Analysis Test**

Chemical analysis of the material used for manufacture of items shall be conducted to check the conformity of the same with Technical Specification and approved drawing.

## **3.0 TESTS ON ALL COMPONENTS (AS APPLICABLE)**

### **3.1 Chemical Analysis of Zinc used for Galvanizing**

Samples taken from the zinc ingot shall be chemically analysed as per IS-209. The purity of zinc shall not be less than 99.95%.

### **3.2 Tests for Forgings**

The chemical analysis hardness tests and magnetic particle inspection for forgings, will be as per the internationally recognised procedures for these tests. The, sampling will be based on heat number and heat treatment batch. The details regarding test will be as discussed and mutually agreed to by the Contractor and Owner in Quality Assurance Programme.

### **3.3 Tests on Castings**

The chemical analysis, mechanical and metallographic tests and magnetic particle inspection for castings will be as per the internationally recognised procedures for these tests. The samplings will be based on heat number and heat treatment batch. The details regarding test will be as discussed and mutually agreed to by the Contractor and Owner in Quality Assurance Pro





**52 Terminal Block**

All internal wiring to be connected to the external equipment shall terminate on terminal blocks, preferably vertically mounted on the side of cabinet, junction box, terminal box and marshalling box.

The terminal blocks shall be made of moulded, non-inflammable thermosetting plastic. The material of terminal block moulding shall not deteriorate because of varied conditions of heat, cold humidity, dryness etc. that would be anticipated at the location where the equipment is proposed to be installed.

The terminal shall be such that maximum contact area is achieved when a cable is terminated. The terminal shall have a locking characteristic to prevent cable from escaping from the terminal clamp unless it is done intentionally. The terminal blocks shall be non-disconnecting stud type equivalent to Elmex type CAT-M4.

The conducting part in contact with cable shall be tinned or silver plated. The terminal blocks shall be of extensible design. The terminal blocks shall be of 1100 V grade and shall be rated to carry continuously the maximum current that is expected to be carried by the terminals.

The terminal blocks shall be fully enclosed with removable covers of transparent, non-deterioration type plastic material. Insulating barriers shall be provided between the terminal blocks. These barriers shall not hinder the operator from carrying out the wiring without removing the barriers.

The terminals shall be provided with the marking tags for wiring identification.

The blocks shall be provided with 20% spare terminals unless otherwise specified. Unless otherwise specified, terminal blocks shall be suitable for connecting the following conductors on each side.

All circuits except CT/VT    Minimum of two 2.5 sq.mm copper flexible

All CT/VT circuits            Minimum of 4 nos. of 2.5 sq.mm copper flexible

AC/DC Power supply circuit    One of 16 sq. mm. Aluminium.

There shall be a minimum clearance of 250 mm between the first row of terminal block and the cable gland plate or side of the box. Also the clearance between two rows of terminal blocks shall be a minimum of 150 mm.

The arrangements shall be in such a manner so that it is possible to safely connect or disconnect terminals on live circuits and replace fuse links when the cabinet is live. Cabinet wiring should be suitable for 60°C as the space heaters will keep the temperature 10°C higher than the ambient.

For the Control and Relay Panels the terminal blocks for current transformer and voltage transformer secondary lead shall be provided with test links and isolating facilities. Also current transformer secondary leads shall be provided with short circuiting and earthing facilities.

**53 Wiring**

All wiring shall be carried out with 1100 V grade stranded copper wires. The minimum size of the stranded conductor used for internal wiring shall be as follows:

1. All circuits except CT circuits 2.5 sq.mm
2. CT circuits 2.5 sq. mm (minimum number of strands shall be 3 per conductor).

All internal wiring shall be securely supported, neatly arranged readily accessible and connected to equipment terminals and terminal blocks.

Wire terminations shall be made with solderless crimping type of tinned copper lugs which firmly grip the conductor and insulation. Insulated sleeves shall be provided at all the wire terminations. Engraved core identification plastic ferrules marked to correspond with the wiring diagram shall be fitted at both ends of each wire. Ferrules shall fit tightly on the wires shall not fall off when the wires and shall not fall off when the wire is disconnected from terminal blocks.

All wires directly connected to trip circuit breaker shall be distinguished by the addition of a red coloured unlettered ferrule. Number 6 & 9 shall not be included for ferrules purposes.

All terminals including spare terminals of auxiliary equipment shall be wired upto terminal blocks. Each equipment shall have its own central control cabinet in which all contacts including spare contacts from all poles shall be wired out. Inter-pole cabling for all equipment's shall be carried out by the Contractor.

#### **54 Equipment Erection Notes**

All support insulators, circuit breaker and other fragile equipment shall preferably be handled with cranes with suitable booms and handling capacity.

The slings shall be of sufficient length to avoid any damage to insulator due to excessive swing, scratching by sling ropes etc.

For cleaning the inside and outside of Hollow insulators only muslin or leather cloth shall be used.

Handling equipment, sling ropes etc. should be tested before erection and periodically for strength.

Bending of compressed air piping should be done by a bending machine and through cold bending only. Bending shall be such that inner diameter of pipe is not reduced.

Cutting of the pipes wherever required shall be such as to avoid flaring of the ends, and only a proper pipe cutting tool shall be used. Hack-saw shall not be used.

The Contractor shall arrange at site all the equipments, instruments and auxiliaries required for testing and commissioning of equipment.

#### **STORAGE OF EQUIPMENTS**

The Contractor shall provide and construct adequate storage shed for proper storage of equipments. Weather sensitive equipment shall be stored indoor. All equipments during storage shall be protected against damage due to acts of nature or accidents. The storage instruction of the equipment manufacturer/Owner shall be strictly adhered to.

**55 Danger Notice Plates****1. SCOPE**

This Specification covers Danger Notice Plates to be displayed in accordance with rule No. 35 of Indian Electricity Rules, 2003.

**2. APPLICABLE STANDARDS**

Unless otherwise modified in this specification, the Danger Notice Plates shall comply with IS:2551-1982 or the latest version thereof.

**3. DIMENSIONS****3.1** Two sizes of Danger Notice Plates as follows are recommended:

- a) For display at 415 V installations - 200x150mm
- b) For display at 11 KV (or higher voltages) installations - 250x200mm

**3.2** The corners of the plate shall be rounded off.**3.3** The location of fixing holes as shown in Figs. 1 to 4 is provisional and can be modified to suit the requirements of the purchaser.**4. LETTERINGS**

All letterings shall be centrally spaced. The dimensions of the letters, figures and their respective position shall be as shown in figs. 1 to 4. The size of letters in the words in each language and spacing between them shall be so chosen that these are uniformly written in the space earmarked for them.

**5. LANGUAGES****5.1** Under Rule No. 35 of Indian Electricity Rules, 2003, the owner of every medium, high and extra high voltage installation is required to affix permanently in a conspicuous position a danger notice in Hindi or English and, in addition, in the local language, with the sign of skull and bones.**5.2** The type and size of lettering to be done in Hindi is indicated in the specimen danger notice plates shown in Fig. 2 and 4 and those in English are shown in Figs. 1 and 3.**5.3** Adequate space has been provided in the specimen danger notice plates for having the letterings in local language for the equivalent of 'Danger', '415', '11000' and 'Volts'.**6. MATERIAL AND FINISH**

The plate shall be made from mild steel sheet of at least 1.6mm thick and vitreous enameled white, with letters, figures and the conventional skull and cross-bones in signal red colour (refer IS:5-1978) on the front side. The rear side of the plate shall also be enamelled.

**7. TESTS**

The following tests shall be carried out :

- i) Visual examination as per IS:2551-1982
- ii) Dimensional check as per IS:2551-1982
- iii) Test for weather proofness as per IS:8709-1977 (or its latest version)

**8. MARKING**

Maker's name and trade mark and the purchaser's name shall be marked in such a manner and position on the plates that it does not interfere with the other information.

**9. PACKING**

The plates shall be packed in wooden crates suitable for rough handling and acceptable for rail/road transport.

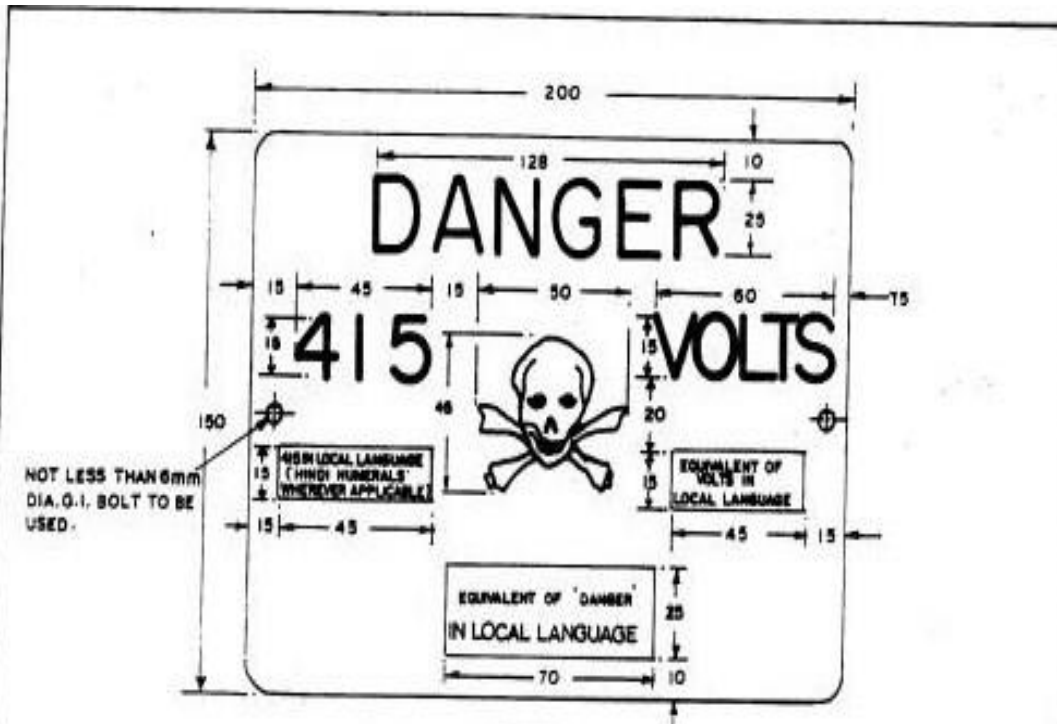

FIG:- 1

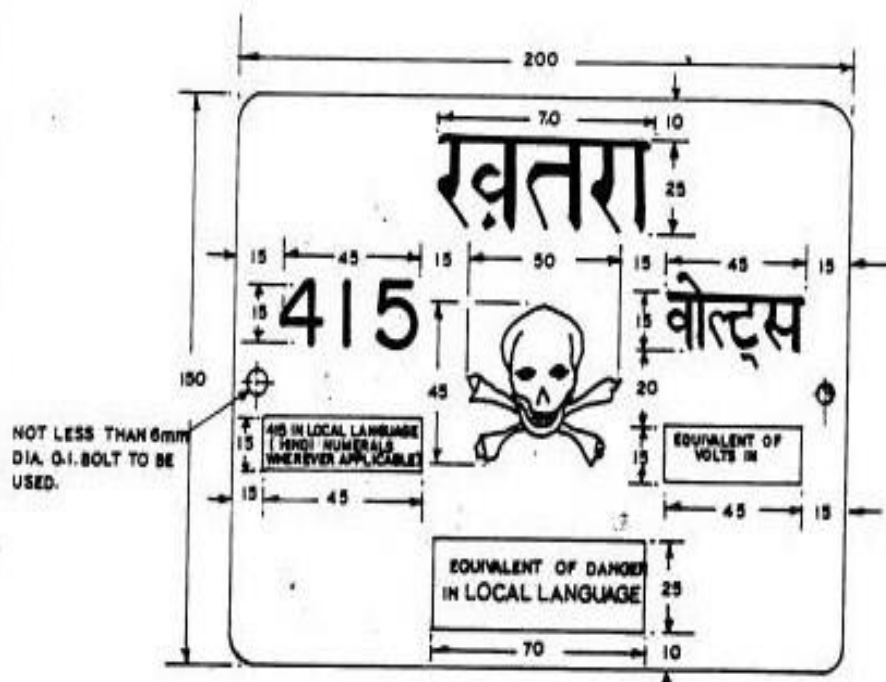

FIG. - 2

ALL DIMENSIONS ARE IN MM.

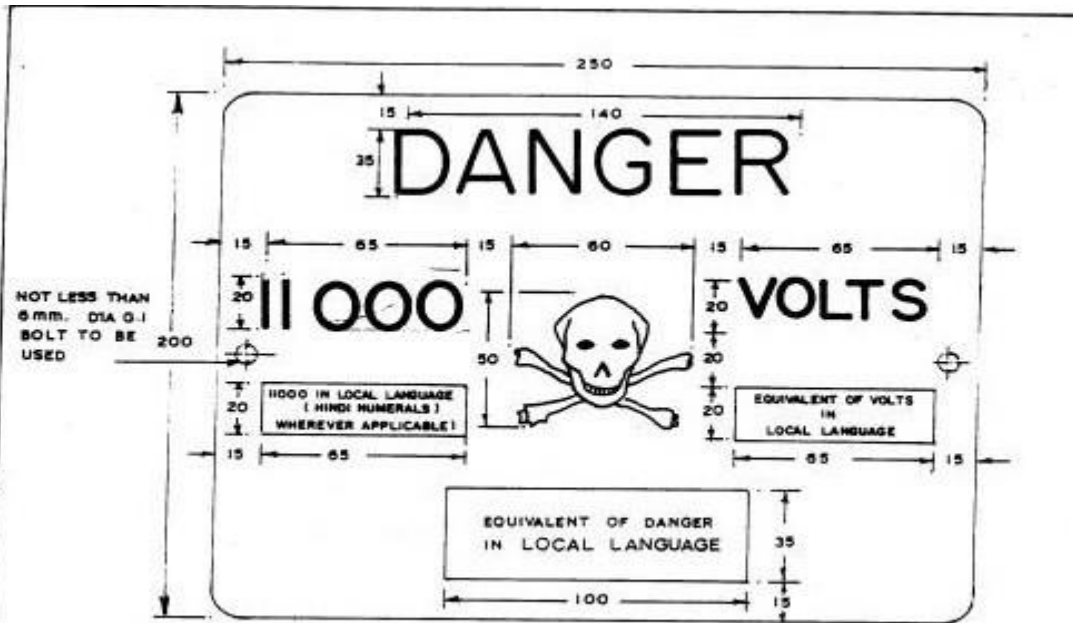

FIG. - 3

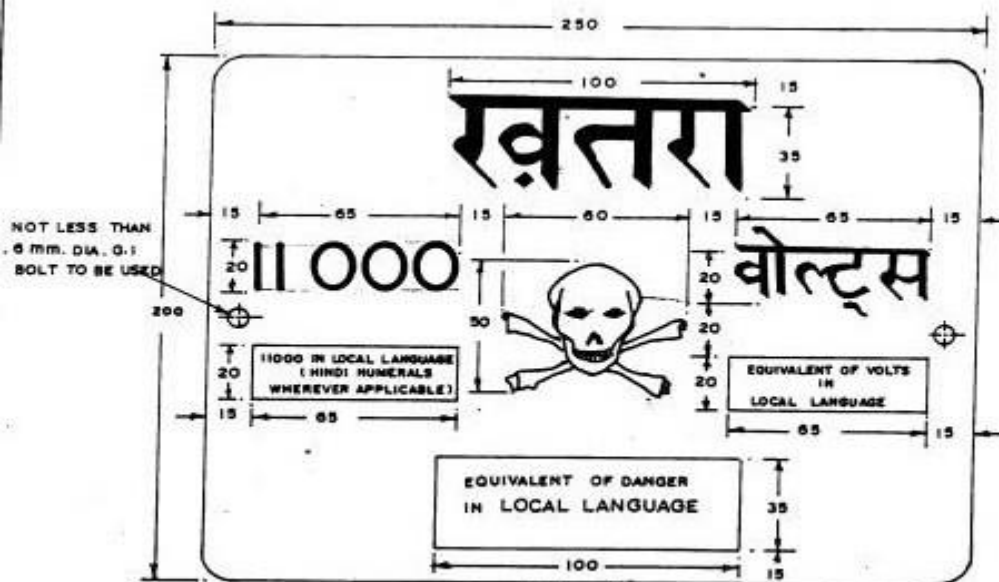

FIG. - 4

NOTE: 11000 SHALL BE REPLACED BY 33000, 66000 ETC. AS REQUIRED.

ALL DIMENSIONS ARE IN MM.

**56 Number Plate (Support)**

Weather proof number plate shall have unique name are to be installed on the pole support. The plate shall be made from mild steel sheet of at least 1.6mm thick and vitreous enameled white, with letters in signal red color (refer IS: 5-1978) on the front side. The rear side of the plate shall also be enameled. The digits shall be as under:

**110121**

**000001**

**226**

Digits shall be displayed as detailed above having at-least 25mm height. The over all size of the plate shall be 200x250mmx1.6mm. The corners of the plate shall be rounded off. All lettering shall be centrally spaced. The dimensions of the letters, figures and their respective position shall be as shown above. The size of digits and spacing between them shall be so chosen that these are uniformly written in the space earmarked for them. The type and size of digits to be written in English as indicated above. The plate should be provided with 6mm dia holes in horizontal alignment for fixing to the pole by means of Galvanized MS flat clamp of 25x3 mm size. The nut & bolts used for fixing of plate should be of galvanized and washers of electro-plated. The bolt should be used of at-least 6mm diameter.

TESTS: The following tests shall be carried out:

- i) Visual examination as per IS:2551-1982
- ii) Dimensional check as per IS:2551-1982
- iii) Test for weather proof-ness as per IS 8709-1977 (or its latest version).

**Numbering Transformer/ Feeders/ Equipments ( in Grid Sub-Station ):**

All augmented/ new power transformer, Breakers, Outgoing feeders, respective control panels, Kiosks are to be named. Base should be painted with yellow paint and black digits should be displayed of at-least 25mm height. Experienced painter should be used to provide this work. LT and HT bushing should be colour coded, CT and PT panels are to be named. The Yellow base plate should be encircled by a black strip. Naming shall be in the local as well as English language.

**Numbering of control panel:**

Name of Feeder should be displayed on front end and at rear end along with serial number of the panel. Yellow base paint and 25mm high black digits are to be used for this purpose. The base paint should be encircled by a black strip. Naming shall be in the local as well as English language.



Strip  
25mm Height



15

**57 Cable Glands and Lugs**

Cable glands shall be Double compression type, tinned/Nickel plated (coating thickness not less than 20 microns in case of tin and 10 to 15 microns in case of nickel) brass cable glands for all power and control cables. They shall provide dust and weather proof terminations. They shall comprise of heavy duty brass casting, machine finished and tinned to avoid corrosion and oxidation. Rubber components used in cable glands shall be neoprene and of tested quality. Required number of packing glands to close unused openings in gland plates shall also be provided.

The cable glands shall be tested as per BS: 6121. The cable glands shall also be duly tested for dust proof and weather proof termination.

Cables lugs shall be tinned copper solder less crimping type conforming to IS: 8309 and 8394 suitable for aluminum or copper conductor (as applicable). The cable lugs shall suit the type of terminals provided. The cable lugs shall be of Dowell make or equivalent.

**58 Cables Tags and Markers**

Each cable and conduit run shall be tagged with numbers that appear in the cables and conduit schedule.

The tag shall be of aluminum with the number punched on it and securely attached to the cable conduit by not less than two turns of 20 SWG GI wire conforming to IS: 280. Cable tags shall be of rectangular shape for power cables and of circular shape for control cables.

Location of cables laid directly underground shall be clearly indicated with cable marker made of galvanized iron plate.

Location of underground cable joints shall be indicated with cable marker with an additional inscription "Cable Joint".

The marker shall project 150 mm above ground and shall be spaced at analysis interval 30 meters and at every change in direction. They shall also be located on both sides of road and drain crossings.

Cable tags shall be provided on all cables at each end (just before entering the equipment enclosure), on both sides of a wall or floor crossing and on each duct/ conduit entry. Cable tags shall be provided inside the switchgear, motor control centers, control and relay panels, etc., wherever required for cable identification, such as where a number of cables enter together through a gland plate.

The price of cable tags and markers shall be included in the installation rates for cables/ conduits quoted by the contractor.

Specific requirements for cabling for cabling, wiring, ferrules as covered in respective equipment section shall also be complied with.

**CABLE GLANDS**

Double compression type cable glands shall be provided by the Contractor for all power and control cables to provide dust and weather proof termination. Required number of packing glands to close unused openings in gland plates shall also be provided.

**CABLE LUGS**

Solderless crimping of terminals shall be done by using corrosion inhibitory compound. The cable lugs shall suit the type of terminals provided. Crimping tool used shall be of approved design and make.

Storage and handling of cable drums

Cable drums shall be unloaded, handled and stored in an approved manner. Rolling of drums shall be avoided as far as practicable. For short distances, the drums may be rolled provided they are rolled slowly and in proper direction as marked on the drum. In absence of any indication the drums may be rolled in the same direction it was rolled during taking up the cables.

**CABLE SUPPORTS AND CABLE TRAY MOUNTING ARRANGEMENTS**

Cable trenches in the control room are normally provided with embedded steel inserts on concrete floors/ walls. The Contractor shall secure supports by welding to these inserts or available building steel structures.

Insert plates will be provided at an interval of 600 mm wherever cables are to be supported without the use of cable trays, while at all other places these will be at an interval of 2000 mm.

## **CABLE TERMINATIONS AND CONNECTIONS**

The termination and connection of cables shall be done strictly in accordance with cable and termination kit manufacturer's instructions, drawing and/ or as directed by the Owner.

The work shall include all clamping, fittings, fixing, plumbing, soldering, drilling, cutting, taping, heat shrinking (where applicable), connecting to cable terminal, shorting and grounding as required to complete the job.

The equipment will be generally provided with un-drilled gland plates for cables/ conduit entry. The Contractor shall be responsible for drilling of gland plates, painting, and touching up. Holes shall not be made by gas cutting.

The Contractor shall tag/ferrule the control cable cores at all terminations, as instructed by the Owner. In panels where a large number of cables are to be terminated and cable identification may be difficult, each core ferrule may include the complete cable number as well. Spare cores shall be similarly tagged with cable numbers and coiled up.

Control cables shall have stranded copper conductor. Bare portion of the solid conductors shall be tinned after removing the insulation and shall be terminated directly without using cable lugs.

All cable entry points shall be sealed and made vermin and dust proof. Unused openings shall be effectively closed.

If the cable-end box or terminal enclosure provided on the equipment is found unsuitable and requires modification, the same shall be carried out by the Contractor with the approval of the Owner.

## **DIRECTLY BURIED CABLES**

The Contractor shall construct the cable trenches required for directly buried cables. The scope of work and unit rates for construction of cable trenches for cables shall include excavation, preparation of sand bedding, soil cover, supply and installation of brick or concrete protective cover, back filling and reaming, supply and installation of route markers and joint markers. The Contractor/Supplier shall ascertain the soil conditions prevailing at site, before quoting the unit rates. Laying the cable and providing protective covering shall be as per approved drawing.

### **Installation of cables**

Power and control cables shall be laid in separate tiers. The order of laying of various cables shall be as follows:

- Power cables on top tiers.
- Control, instrumentation and other service cables in bottom tiers.

Single core cable in trefoil formation shall be laid with a distance of three times the diameter of cables between trefoil center lines. All power cables shall be laid with a minimum center to center distance equal to twice the diameter of the cable.

Power and control cables shall be securely fixed to the trays/ supports. Trefoil clamps for single core cables shall be pressure die-cast aluminum (LM-6). Nylon-6 or fiber glass and shall include necessary fixing nuts, bolts, washer, etc. These are required at every 2 meter of cable run. Vertical and inclined cable runs shall be secured with 25 mm wide and 2 mm thick aluminum strip clamps at every 2 m. Horizontal runs in cable trays and trenches shall be secured using 4 mm nylon cord at every 2 m.

Cables shall not be bent below the minimum permissible limit. The minimum bending radius of power cables shall be 12D and that of control cables shall be 10D, where D is overall diameter of cable.

Where cables cross roads, drains and rail tracks, the cables shall be laid in reinforced spun concrete or steel pipes, buried at not less than one meter depth.

In each cable run some extra length shall be kept at a suitable point to enable one (for LT Cables) or two (for H.T. cables) straight through joints to be made, should the cable develop fault at a later date.

Selection of cable drums for each run shall be so planned as to avoid using straight through joints. Cable splices will not be permitted except where called for by the drawings, unavoidable or where permitted by the Owner.

Control cable terminations inside equipment enclosures shall have sufficient lengths so that switching of termination in terminal blocks can be done without requiring any splicing.

Metal screen and armour of the cable shall be bonded to the earthing system of the station, wherever required.

Rollers shall be used at intervals of about 2.0 meters, while pulling cables.

All due care shall be taken during unreeling, laying and termination of cable to avoid damage due to twist, kink, sharp bends, etc.

Cable ends shall be kept sealed to prevent damage.

Inspection on receipt, unloading and handling of cables shall generally be in accordance with IS:1255 and other Indian Standard codes or practices.

Wherever cables pass through floor or through wall openings or other partitions, wall sleeves with bushes having a smooth curved internal surface so as not to damage the cables shall be supplied, installed and properly sealed at no extra charges.

The erection work shall be carried out in a neat workmanlike manner and the areas of work shall be cleaned of all scrap materials after the completion of work in each area every day. Contractor shall remove the RCC/steel trench covers before taking up the work and shall replace all the trench covers after the erection work in that particular area is completed or when further work is not likely to be taken up for some time.

Contractor shall furnish three copies of the report on work carried out in a particular week, such as cable numbers and a date on which laid, actual length and route, testing carried out, terminations carried out, along with the marked up copy of the cable schedule and interconnection drawing wherever the modifications are made.

In case the outer sheath of a cable is damaged during handling/ installation, the Contractor shall repair it at his own cost, and to the satisfaction of the Engineer-in- Charge. In case any other part of a cable is damaged, the same shall be replaced by a healthy cable, at no extra cost i.e. the Contractor shall not be paid for supply, installation and removal of the damaged cable.

All cable terminations shall be appropriately tightened to ensure secure and reliable connections. The Contractor shall cover the exposed part of all cable lugs whether supplied by him or not with insulating type, sleeve or paint.

**59 Earth Knobs for LT Lines****1. SCOPE**

This standard covers the requirements of knobs for supporting the neutral-cum-earth wire used for earthing of metal parts of supporting structures of overhead power lines with a nominal voltage upto 1000V (refer Construction Standard B-3 & B-4).

**2. APPLICABLE STANDARDS**

Except when they conflict with the specific requirements of this specification, the earth knobs shall conform to the latest version of IS:9511-1980.

**3. MATERIALS**

Earth knobs shall be made of cast iron.

**4. GENERAL REQUIREMENTS**

Earth knobs shall not have blow holes, shrinkage and other casting defects. The top and bottom flat portion of earth knob shall be smooth and plain.

**5. SHAPE AND DIMENSIONS**

The shape and dimensions of earth knob shall conform to Fig. 1.

**6. ACCEPTANCE TESTS**

The following acceptance tests shall be carried out atleast on one knob for every 1000 nos.

**6.1 Electrical Resistance**

**6.1.1** The electrical resistance of the earth knob shall be measured using a Kelvin bridge. Adequate electrical contact shall be ensured against the two surfaces of the knob preferably by using brass washers, soldered to the leads going to the bridge circuit. The washers shall be of adequate size to ensure sufficient area of contact.

**6.1.2** The electrical resistance of the earth knob, measured as given in 6.1.1 between the two flat portions, shall not exceed 200 m ohms.

**6.2 Mechanical Strength**

The breaking strength at the neck of the earth knob shall not be less than 11,500 kg. when force is applied in the direction shown in Fig. 2.

**7. MARKING**

Each earth knob shall be marked with the name of the manufacturer or his trade mark.

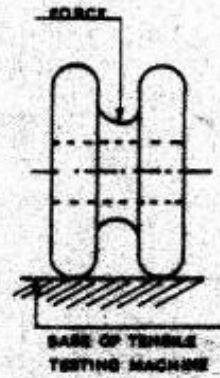
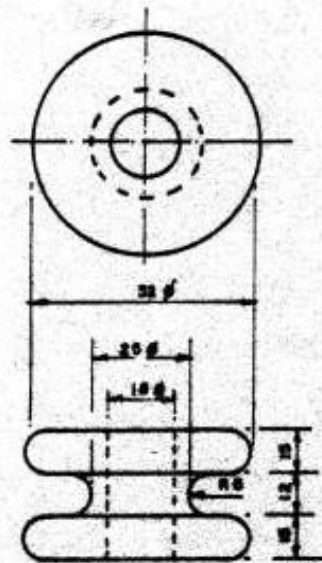

एल. टी. लाइनों के लिए अर्थनब  
EARTH KNOB FOR LT. LINES

**60 GI Wires**

**1. SCOPE**

This specification covers details of solid G.I. Wires for use in rural distribution system.

**2. APPLICABLE STANDARDS**

Except when they conflict with the specific requirements of this specification, the G.I. wires shall comply with the provisions of IS:280-1978 and IS:7887-1975 or the latest version thereof.

**3. APPLICATION & SIZES**

G.I. wires covered in this Specification are intended for the following applications :

<b>Application</b>	<b>Sizes (nominal dia)</b>
Bearer wire for service	3.15mm (for single phase cables services ) 4 mm ( for three phase services)
Earthing of Transformers, poles & Fittings.	4 mm
Continuous Earthwire for. 11 KV lines	4 mm
Protective guarding at the crossing of over-head power lines with roads, railway tracts and telecommunication lines	3.15, 4 and 5 mm

**4. MATERIAL**

**4.1** The wires shall be drawn from the wire rods conforming to IS:7887-1975 or the latest version thereof.

**4.2** The requirements for chemical composition for the wires shall conform to IS:7887.

**4.3** The wires shall be sound, free from split surface flaws, rough jagged and imperfect edges and other detrimental defects on the surface of the wires.

**5. GALVANISING**

The wires shall be galvanised with 'Heavy Coating' as per IS:4826-1979 or the latest version thereof.

**6. GRADES**

GI wires shall be classified into two grades based on their tensile strength :

<b>Grade</b>	<b>Tensile Strength (MPa)</b>
Annealed	300-550
Hard	550-900



**7. TOLERANCE IN DIAMETER**

The tolerance on nominal diameter at any section of wire shall not exceed ( $\pm$ )2.5%. Further, the maximum difference between the diameters at any two cross-sections of wires shall not exceed 2.5%.

**8. TESTS**

The following tests shall be carried out in accordance with IS:280-1978 or the latest version thereof as per sampling criteria stipulated therein :

- i) Dimensional check (dia) - refer clause 7 above.
- ii) Visual inspection regarding freedom from defects refer clause 4.3 above.
- iii) Tensile test
- iv) Wrapping test (for wire diameters smaller than 5mm)
- v) Bend test (for wire diameters 5mm only)
- vi) Coating test - refer clause 5 above
- vii) Chemical composition

**9. PACKING**

The wires shall be supplied in 50-70 kg. coils, each coil having single continuous length. Each coil of wire shall be suitably bound and fastened compactly and shall be protected by suitable wrapping.

**10. MARKING**

Each coil shall be provided with a label fixed firmly on the inner part of the coil bearing the following information :

- a) Manufacturer's name or trade mark
- b) Lot number and coil number
- c) Size
- d) Grade (Annealed or Hard)
- e) Mass
- f) Length
- g) ISI Certification mark, if any

**61 Hot Dip Galvanised GS Solid Wire**

The hot dip galvanized MS Solid wire of sizes 5 mm, 4 mm and 3.15 mm diameters shall conform to the relevant ISS specification, briefed here below: -

**1) MATERIAL**

The Mild Steel wire shall have the chemical composition maximum sulfur - .055%, Phosphorus – 0.055%, Carbon 0.25%. Zinc shall conform to grade Zen 98 specified in IS 209-1966 & IS: 4826-1979 with up to date amendments.

**2) ZINC COATING**

Zinc coating shall be in accordance with IS: 4826-1979 (Col.4.2.1) for heavily coated hard quality.

**3) GALVANISING**

Galvanizing shall be as per IS 2629-1966, IS: 4826-1979 with up to date amendments.

**4) UNIFORMITY OF ZINC COATING**

Uniformity of Zinc coating shall be as per IS 2633-1972 (Col.4.2.1 to 4.2.3) with up to date amendments.

**5) TENSILE PROPERTIES**

The tensile strength of the wire after, galvanizing shall be between 55-95 Kg/Sq.mm (heavily coated Hard as per IS: 4826-1979 Tables-1) ensuring MS wire Mechanical properties as per IS-28-1972 8.1 to 8.3.

**6) FREEDOM FROM DEFECTS**

As per IS 2629-1966 (Cl.6.1) & 4826-1979 (Col.4.3) & with up to date amendments, be ensured.

**7) TESTS**

During the process of manufacture/ fabrication and finish all tests for chemical, mechanical, galvanizing as per IS-280-1979, IS: 1521-1972, IS1755-1961, IS: 6745-1972 & 4826-1979 be carried out. Test certificate towards, chemical composition (as per above) shall be submitted for each lot offered for inspection.

The following tests shall be conducted in presence of owner's representative.

1. Visual Physical inspection and measurement of specified dimensions.
2. Coating test as per IS-1755-1961, IS: 2629-1966, IS: 2633-1972, IS: 4826-1969 & 1979 – IS: 6745-1972.
3. Adhesion test as per IS: 1755-1961, IS: 2629-1966, IS: 2633-1972, IS: 4826-1969 & 1979 – IS: 6745-1972.
4. Tensile strength and breaking load and elongation determined as per IS 1521-1972 with up to date amendments.

**8) PACKING**

Packing shall be as per IS 280-1979 (Col.3.1) and each coil shall be between 50-100 Kg.

**9) MARKING**

As per IS: 280-1972 (Col.14.1 & 14.1.1) is required.

**62 Material Properties and Other Technical Requirements for Heat Shrinkable Cable Terminations and Joints Suitable for XLPE Cables.**

- 1) **GENERAL:** The term heat shrink refers to extruded or moulded polymeric materials which are cross linked to develop elastic memory and supplied in expanded or deformed size or shape.
- 2) **QUALIFYING EXPERIENCE:** The kits should have satisfactory performance record in India in excess of 5 years supported with proof of customers having had satisfactory use of these kits in excess of 5 years.
- 3) **TYPE TEST REPORTS:** The Joints and terminations should have been type tested and type test reports made available.
- 4) **KITS CONTENTS :** The Kits should generally consist of:
  - (a) Heat shrinkable clear insulating tubes
  - (b) stress control tubing where necessary,
  - (c) Ferrule insulating tubing for joints,
  - (d) Conductive cable break outs for terminations, non tracking, erosion and weather resistant tubing both outer / inner
  - (e) non tracking erosions and weather resistant outdoor sheds in case of terminations
  - (f) high permittivity mastic wedge
  - (g) Insulating mastic.
  - (h) Aluminium crimping lugs of ISI specification.
  - (i) Tinned copper braids
  - (j) Wrap around mechanical protection for joints.
  - (k) Cleaning solvents, abrasive strips.
  - (l) Plumbing metal.
  - (m) Binding wire etc. adequate in quantity and dimensions to meet the service and test conditions.

The kit shall have installation instructions and shall be properly packed with shelf life of over 3 years.

**63 4-in-1 & 6-in-1 DEEP DRAWN METAL METER BOX WITH MULTIPLE OUTGOING CONNECTOR (MOC) FOR SINGLE PHASE ENERGY METERS****1. SCOPE**

This specification covers the design, manufacture, testing, pre-dispatch inspection by purchaser and supply of outdoor type MS sheet, Deep Drawn Metal Meter Box from the manufacturers having satisfactory performance with Power Utilities in last 5 years. Metal Meter box shall be used for housing **4Nos. & 6Nos.** single phase energy meters respectively of any make for electric connections of General categories.

**2. CONSTRUCTIONAL AND TECHNICAL PARTICULARS:**

- 2.1 Metal Meter Box (MMB) shall be corrosion free. It should be suitable for housing four single phase energy meters of any make. The MMB shall conform to attached drawings. The overall dimensions of MMB shall be 560x425x140mm (i.e. height x width x depth) for 4-in-1 Meter Box and 920x425x140mm (i.e. height x width x depth) for 6-in-1 Meter Box.
- 2.2 The Metal Meter Box (MMB) shall be made from 18 SWG CRCA MS sheet by **Deepdrawn** method. The base and cover of the MMB shall be individually in one piece without any welding joint. The fixing of the accessories like hinges, clamps, handle etc. shall be spot-welded. The cover of MMB shall be fixed with three tamper proof hinges welded inside and not visible from outside. The hinge pin diameter shall be 3mm. Hinges shall be made from 1.6mm MS sheet. The pins of hinges shall have head on top so that it does not fall down after wear & tear. The door of MMB shall open from right to left by a minimum of 90°. The collar of the door (cover) in closed position shall rest on the collar of the body (base) of MMB. The collar of the door shall overlap the collar of the body of MMB by 8mm. The collar of the body shall be provided with good quality rubber gasket lining of minimum 4mm thickness. Thickness of rubber lining shall be such that it provides proper sealing between the cover & base of MMB to avoid penetration of dust & ingress of water. Rubber lining should be fixed with good quality adhesive so that the same does not get removed on opening of the door. Three numbers 'U' shaped latch arrangement shall be provided to Seal the cover with base as shown in drawing. 2mm & 8mm diameter hole shall be provided in U-shaped latch for sealing wires & padlock. Holes provided for sealing & padlock should be aligned when latch is in closed position. Strips of U-latch shall be welded from inner side of the box. Complete U-latch arrangement shall be made from sheet thickness of 1.6mm and stainless steel rivet.
- 2.3 Viewing window openings of the size 90x100mm as indicated in the drawing shall be provided to facilitate taking of meter readings. Each Viewing window shall be provided with toughened glass of 5mm thickness. Glass shall have scratchproof logo on the right side top corner of the glass. Each glass shall be fixed inside the cover of MMB, with powder coated single piece drawn metal frame (Glass Holder) made of 20 SWG MS sheet fixed with min. four welded screws & nuts. The glass holder screws & nuts shall be inside the cover so that it cannot be opened from outside. Glass holder shall have rectangular cuttings as per details shown in drawing. The size of toughened glass shall be 110mm x 120mm so as to provide overlap of 10mm. The glass has to be fitted with a wrap around good quality rubber ring without joint having minimum depth of 8mm, so that it can with stand weather effect.
- 2.4 A handle of minimum 75mm length, 10mm width and 20 SWG sheet thickness should be provided for opening and closing of the cover at the place as shown in the drawing.
- 2.5 There shall be independent mounting arrangement for each meter as shown in the drawing. The meter mounting arrangement shall consist of two slotted strips & hanger bracket welded on the base of box as shown in drawing. The meter mounting arrangement should be raised from the base of Metal Meter Box (MMB) body by 15mm. Zinc plated adjustable strip shall be provided on meter mounting arrangement for fixing of the meters. Hanger bracket shall be provided with a screw of M4 threads and adjustable strip shall be provided with two nuts of M4 threads and 25mm long screws for fixing of the meters.
- 2.6 Four Nos. pole-mounting holes of 10mm diameter at the back of Metal Meter Box (MMB) shall be provided to fix the MMB on Poles. For fixing of MMB on poles, suitable clamps complete with nut, bolts & washers shall be provided with each box. For mounting of MMB on poles, 2 Nos. zinc plated / powder

- coated clamping strips shall be provided to fix the MMB with pole. Nuts & bolts shall be properly zinc plated.
- 2.7 Louvers for ventilation shall be provided on the sidewalls of the box as shown in drawing. 20SWG perforated sheet shall be welded from inside of the louvers suitable for IP-33 protection class.
- 2.8 Two holes for incoming cable (For Loop in and Loop out) shall be provided as shown in drawing. For outgoing cables 4Nos. holes for 4-in-1 Meter Box and 6Nos. holes for 6-in-1 Meter Box shall be provided as shown in the drawing. Cable holes shall be provided with superior quality rubber / plastic cable glands. Internal diameter of incoming gland shall be 30mm (minimum), and for outgoing gland shall be 20mm. Glands shall be made such that internal diameter of glands provided for cables should be closed with the film of minimum 1mm thickness. Cable will go through the cable glands by cutting the film of the glands.
- 2.9 Multiple Outgoing Connectors (MOC) for Phase and Neutral shall be provided at the top of the MMB as indicated in drawing. The Multiple Outgoing Connectors (MOC) shall be rated for minimum 300 Amp and 1100 Volts. Current carrying parts of MOC shall be protected & enclosed in a fire resistant insulated casing. The insulation shall be made of suitable material capable of durably withstanding the mechanical, electrical and thermal stresses to which it may be subjected in service. MOC shall be provided with the holes for incoming & outgoing cables. MOC shall be such that the external conductors inserted in the holes of MOC shall be connected by means of 2 Nos. screws which ensure that the necessary contact pressure corresponding to the current rating of MOC is maintained. Current carrying parts of Multiple Outgoing Connector including screws shall be at a safe distance from the outer edge of the insulation and shall not be accessible by hand / finger. Multiple Outgoing Connectors (MOC) used for Phase and Neutral shall have provision for fixing of one Nos. main incoming & one Nos. main outgoing cable and 4 Nos. outgoing for 4-in-1 and 6Nos. outgoing for 6-in-1 Meter Box. MOC shall be suitable for size of outgoing cable up to 10mm<sup>2</sup> and main incoming & main outgoing cable up to 25mm<sup>2</sup>. Multiple Outgoing Connectors (MOC) shall be provided in Red color for Phase and black color for neutral. The Multiple Outgoing Connectors (MOC) shall be raised from the back side by minimum 25mm.
- 2.10 MMB shall be adequately protected against rust, water and corrosion both from inside and outside. The MMB shall be powder coated with Light Admiralty Grey colour (as per IS-5:1993 Colour No. 697).
- 2.11 Powder Coating: The surface of the MMB shall be properly pre-treated and cleaned in 7 tank process and shall be applied with a powder coating of 40 micron thickness on outer side and inside. The facility for 7-Tank Phosphating & powder coating shall be in house of the tenderer / manufacturer to ensure proper quality since these boxes are for outdoor applications.
- 2.12 Two earthing bolts of diameter 8mm and 25mm long shall be welded from inside of the box and shall be provided with 2 nuts & washer. Earth marking shall be duly embossed near the earth bolts. There shall be no powder coating on the earthing bolts.
- 2.13 All the screws, nuts and washers shall be properly zinc plated.
- 2.14 The tolerance permissible on the overall dimension of the Metal Meter Box (MMB) shall be ( $\pm$ ) 3.5% and permissible tolerance on weight shall be -2%. Any weight on positive side will be acceptable. However, the tolerance for the fittings shall be ( $\pm$ ) 3%. In case of an order, the actual weight of sample shall be mentioned for supplies.
- 2.15 Danger Marking shall be provided on the box in red colour.
- 2.16 Utility name and manufacturer name shall be provided on the door of meter box.
- 3.** The box shall comply with the requirement of IP33. The box shall be fully type tested along with dimensions, as per the requirement of IS 13947 (Part-1):1993. The type test shall be carried out from the govt.-approved laboratories & shall be submitted along with the tender failing which Part-III of tender (Price Bid) of the firm shall not be opened. Government approved laboratories should be accredited by the National Board of Testing & Calibration Laboratories (NABL) of Govt. of India. The type test report shall not be older than 3 years.

**4. INSPECTION:**

The manufacturer / supplier shall give minimum 14 days advance notice about the readiness of material at his works. Representative of the Power Utility will inspect the material for conformity with specification before the same is accepted.

**5. TESTS:**

Following tests shall be performed on the box during inspection:

**5.1 Visual Examination: -**

The MMB shall be inspected visually, externally and internally for proper Powder Coating layer, fitting of all the components in accordance with technical Specification.

**5.2 Verification of dimensions: -**

Verification of dimensions, external / internal clearances will be carried out as per technical specifications.

**5.3 Verification of fittings: -**

Components like insulated Multiple Outgoing Connectors, screws etc will be verified as per technical specification and usage requirement.

**5.4 High voltage withstand test at 2.5KV: -**

The A.C. voltage of 2.5KV, 50HZ shall be applied for one minute as follows:

- a) Between Phase & Neutral
- b) Between Phase and earth screw
- c) On the insulation of Multiple Outgoing Connector.

There shall not be any puncture or flash over during this test.

**5.5 Current Carrying Capacity: -**

The Current of 300 AMP shall be applied for 30 minutes through high current source on each Multiple Outgoing Connector. There shall not be overheating of the Connectors during this test.

**6. PACKING:**

The Metal Meter Box (MMB) shall be suitably packed in 3 ply corrugated boxes in order to avoid damage in transit.

**7. PAST EXPERIENCE:**

The firm must have supplied the NIT quantity or similar item to any Power utility in any one financial year in last 5 years. Past performance of the manufacturer firm with Power utilities should be satisfactory both in quality and adhering to delivery schedule in last 5 years. Supporting documents shall be submitted along with the tender.

**8. Prototype & Drawings:-**

The manufacturer has to manufacturer the prototype Unit for each rating as per this specification before bulk manufacturing. The manufacturer should intimate the readiness of prototype to employer. The Project Manager will inspect the prototype for approval. The manufacturer should submit the final drawings in line with this specification and prototype to employer for approval before bulk manufacturing. The approval of prototype & drawings shall be a responsibility of manufacturer/Contractor. Tentative drawing of box is enclosed herewith.

**20-in-1 Meter Pillar Box (MPB) for single phase meters****1. SCOPE:**

This specification covers the design, manufacture, inspection, testing and supply of outdoor type M.S. sheet, Meter Pillar Box from the manufacturers having satisfactory performance with power utilities in last 5 years. Meter Pillar Box shall be used for housing Single Phase meters for electric connections of general category.

**2. CONSTRUCTIONAL AND TECHNICAL PARTICULARS:**

- 2.1 The meter pillar box shall conform to tender drawings. It should be suitable for housing 20 Nos. single phase energy meters of any make. The overall dimensions of the Meter Pillar Box shall be 1280mmx1115mmx200mm (i.e. height x width x depth) with suitable canopy at the top. A sliding bolt of 20mm width, 6mm thickness & 245mm length to be provided for extra locking as well as sealing arrangement to be provided as shown in Annexure-1& 8. Hole of 8mm shall be provided in the sliding bolt to provide the padlock. Other parts of the latch shall be made from 2mm thick MS sheet. The sliding bolt shall be duly powder coated. Suitable openings to drain out rain water, of minimum size be provided at bottom so that no reptile is able to enter pillar box.
- 2.2 Pillar box shall be fabricated from 18 SWG (1.2mm), M.S sheet by die-press method and having bottom frame made out of MS angle 40mmx40mmx5mm. The MS Angle Iron used should be manufactured by any 'BIS' approved manufacturer. The name of the manufacturer shall be marked on the angle iron and the document showing BIS approval of the manufacturer shall be shown to the inspecting officers and attached with the inspection report. Single piece of MS sheet be used for three side of box i.e. back, left and right side be of one piece. Top side of the same sheet must be bent at 90° from all three sides by 15mm and shall be welded at corners for strengthening of the box. For fabricating the box, maximum 4 Nos. of pieces should be used i.e. one piece for three sides, second piece for bottom side third & fourth piece for top side with canopy. In addition to this, left & right doors (as shown in Annexure 2 & 3) have to be fixed with hinges. All the welding joints should have 15mm overlapping. The meter pillar box shall have door (with left & right side partition) for facilitating access to meter reading from outside. Two holes of about 6mm diameter shall be provided on each side of upper canopy (as shown in drawing ) for fixing cable spacers at site.
- 2.3 All the steel sections used in fabrication shall be carefully leveled and straightened before any work is done on them. No rough edges shall be permitted anywhere throughout the work. The material shall be capable to withstand mechanical, electrical and thermal stresses as well as the effects of humidity, which are likely to be encountered during its service. Welding shall be MIG welding or spot welding only. Welding work shall be done carefully so as to avoid over heated spots, cavities, porosity, burns and dents etc.
- 2.4 The hinge arrangement of the door shall consist of three-tamper proof inside hinges not visible from outside. Each door shall have minimum three hinges. One end of Hinges should be welded on inside of the door and other end should be fixed with Pillar Box by minimum three screws. Hinges arrangement shall be made from 16SWG (1.6 mm) M.S. Sheet. For extra strengthening of the doors, C-shaped channels shall be spot welded/ MIG welded from inside of the box (as shown in tender Drawing). Two no. such Channels shall be provided on the left door and one no. on the right door. The thickness of the sheet of channels shall be 1.2 mm. Viewing window opening of the size 90x100 mm as indicated in drawing (Drawing) shall be provided on the doors to view meter readings of Meters installed inside the Pillar Box. Viewing window shall be provided with toughened glass of 5mm thickness fixed from inside of the doors. Glass shall have scratchproof logo of utility of minimum 10mm height on the right side top corner of the glass. This glass shall be fixed from inside of the doors of pillar box, with single piece drawn metal frame with powder coating (Glass Holder) made of 20 SWG (0.9 mm) MS sheet fixed with min. four screws. Glass holder shall have rectangular cuttings as per details shown in Drawing. The size of toughened glass shall be 110x120mm so as to provide overlap of 10mm with viewing window. Glass has to be fitted with a wraparound rubber ring, in one piece, having minimum depth of 8 mm, made from good quality rubber so that it can withstand weather effect.

- 2.5 Door shall be provided with M.S. handle and locking arrangement (with one key) and suitable gasket, in 4 no. pieces (one piece for each side) with no gap at the joints, to make vermin proof as indicated in drawing (Drawing). Door shall be provided with three point locking arrangement. M.S locking rod of diameter 10mm ( $\pm 0.5$ mm) with protrude of minimum 10mm at top & bottom, provided to prevent opening of the door in locked condition. Locking Patti should be provided from inside of door at the center, for locking purpose so that box gets locked from top, bottom & center in locked condition. The 3-point locking arrangement Patti should move inside the slot provided in the left & right door. Movement of locking Patti & locking rods should be linked with movement of outer handle. Locking rod shall lock the doors by sliding over the rollers provided on the top and bottom of the pillar box. Latch of suitable size, duly powder coated shall be provided on top and bottom on inside of the left door having utility name or logo. There should be a rubber/nylon washer in one piece, fixed with adhesive, between handle and the door to avoid penetration of rain water in Pillar Box through handle. One central lock with brass levers shall be provided inside the door. Key way shall be provided on the door for operating the lock from outside. Key way shall be provided with a cover. Locking arrangement shall be provided with Cover from inside. Keys provided shall be Master key type for ease of handling by utility staff. The handles provided should be of removable type.
- 2.6 Insulated Aluminium Bus bars for 3 Phases and Neutral shall be provided at the top of Pillar box as indicated in drawing. Three Nos. Aluminium bus bars of minimum 300 mm<sup>2</sup> with suitable length for R, Y and B phase and one Aluminium bus bar of 400mm<sup>2</sup> with suitable length shall be provided for neutral. Minimum clearance between each insulated bus bar shall be 60mm & end clearance from pillar box wall shall be minimum 75mm. These insulated bus bars shall be raised from the backside by minimum 25mm. Bus bars shall be protected & enclosed in a fire resistant insulated casing rated for 1100 V. The insulation shall be made of suitable material capable of durably withstanding the mechanical, electrical and thermal stresses to which it may be subjected in service. The insulated bus bars shall be provided with the holes for incoming & outgoing cables in such a way that the external conductors inserted in the holes of bus bars shall be connected by means of bolts/studs which ensure that the necessary contact pressure corresponding to the current rating of insulated bus bars is maintained. Aluminium bus bars including all live parts shall be at a safe distance from the outer edge of the insulation and shall not be accessible by hand. These insulated bus bars used for R-Y-B Phases and Neutral shall provide connections for 20 energy meters to be installed in the Pillar box. Each insulated bus bar shall have arrangement for fixing of 2Nos.main 4 Core XPLE cable of size up to 95mm<sup>2</sup> from the upper side of each bus bar by providing suitable arrangement/mechanism in such a manner that the main cable shall be connected from the upper side of bus bars and do not hang on the insulated bus bars. Each cable up to 95mm<sup>2</sup> shall be fixed with 2 Nos. M12 bolts / studs. Insulated bus bars shall be provided in Red, Yellow, Blue and Black color for R-Y-B Phases and neutral respectively.
- 2.7 There should be independent mounting arrangement for each meter and it should be raised from the back side of pillar box by 35mm. Each meter mounting arrangement shall be provided with the 6mm thick fire resistant insulating, hanger strip and adjustable strip as per drawings. Meter shall be fixed on these insulated strips. The supplier shall supply three mounting M.S. Screw, one screw with 4mm diameter for Hanger point and two Screws (M4 x 35mm) with nuts in the slots of each adjustable strip. The insulation provided should be fire resistant and sufficient gap should be provided so that the screws used for fixing the meters do not touch metal plate at the back or the metal strip.
- 2.8 For outgoing service cables, 20 Nos. holes with rubber cable glands of internal diameter 19mm shall be provided on both side walls of the pillar box (10 Nos. on each side wall). All cable glands shall have grooves of minimum 5mm depth for proper fixing with pillar box sheet. The glands shall be fixed with the central groove over the pillar box sheets, so that half of the gland is inside the pillar box with the other half outside the pillar box. The fire resistant insulation sheet shall be fixed firmly on inside the pillar box, on both sides for the outgoing service cables (each sheet having 10no. holes corresponding to the cable glands). The dia. of the holes in the fire resistant sheets shall be 20 mm. and the diameter of the holes in the pillar box for fixing of cable glands for outgoing service cables shall be 25mm.

The diameter of holes for main incoming and outgoing main cables shall be 60 mm with cable gland of internal diameter 45mm to be provided in the lower wall of the pillar box. All rubber cable glands shall be



properly fixed with suitable adhesive such that, the same does not get removed from Pillar box. Rubber glands shall be made such that internal diameter of glands provided for cables should be closed with the Rubber film of approximately 1mm thickness. Cable will go through the cable glands by piercing the rubber film of the glands. A fire resistant insulation sheet corresponding to the main incoming and outgoing main cables shall be firmly fixed on inside of the pillar box. The diameter of the holes in the insulation sheet shall be about 50mm. 3 Nos. Fire resistant perforated insulation sheets (with requisite undercuts for easy movement of outgoing cables from meters) shall be provided as vertical partition between each meter column for better heat dissipation.

- 2.9 Suitable cable clamps as shown in the drawing shall be provided in the pillar box to hold the main cables.
- 2.10 Louvers for ventilation shall be provided on the sidewalls of the pillar box, top of the front and back side below the canopy as shown in drawing. Louvers shall also be provided in the lower wall of the pillar box. 20SWG (0.9 mm) perforated sheet shall be welded from inside of the louvers.
- 2.11 Bolts of diameter 10 mm and 35 mm length with 2 Nos. plain washers and two no. nut are to be provided on both the sides for earthing the metallic body of the pillar box (Drawing). Earthing bolts is to be provided on the earth clamps welded on both sides of the meter pillar box. The earthing bolt should be provided from inside of the earth clamp. Earthing nut bolt & washer should be zinc plated. There should be no powder coating on top surface of earth clamp and earthing bolts. The thickness of the sheet of the earth clamp (as shown in Drawing) shall be 2mm.
- 2.12 40mmx40mmx5mm angle iron frame with 4 Nos. 750 mm length must be provided as legs of pillar box. The Angle Iron to be used for frame and the legs shall be manufactured by any 'BIS' approved manufacturer. The name of the manufacturer shall be marked on the angle iron and the document showing BIS approval of the manufacturer shall be shown to the inspecting officers and attached with the inspection report. Eight nos. (3 no. each on front & backside and one no. each on left & right sides) Mounting bolts of M10 should be welded on the top of base angle frame to hold the pillar box. Bolts shall be welded to angle frame such that it moves inside the mounting holes made at the bottom of the pillar box and is fixed from inside with nuts & washers. Angle frame should be interchangeable with all pillar boxes. The pillar box should fit on inside of the angle frame, on top of the legs. Further, the legs should be welded with overlap with the angle iron frame. Also there should be anchors of M.S. sheet of square shape with 4" sides of 2.5mm thickness, fixed on bottom of legs.
- 2.13 The tolerances permissible on various dimensions of the pillar box shall be  $\pm 2\%$ .
- 2.14 Rubber sealing/lining at least be 3mm thick shall be provided on 4 sides of the box in 4 no. pieces (one piece for each side) with no gap at the joints. to ensure proper closing of the outer door and to avoid ingress of water. It should be properly glued on the surface with the help of suitable adhesive so that the same does not get removed by itself on opening the door.
- 2.24 2.15 The pillar boxes (including Glass Holders) should be powder coated with light admiralty grey shade (Shade No-697 as per IS: 5:2007) suitable for outdoor use. The surface of the pillar boxes and Glass Holders shall be properly pre-treated and cleaned in 7 tank process and shall be applied with a powder coating of about 40 micron thickness on outer side and inside. The facility for 7-Tank Phosphating & powder coating shall be in house of the tenderer / MMB manufacturer to ensure proper quality.

### **3.0 WIRING OF PILLAR BOX:**

For Internal wiring of Pillar Box, 'ISI' marked PVC insulated, unsheathed Copper cable of 10mm<sup>2</sup>, shall be used. Copper cable shall have 140 strands of Copper wire with 0.3mm diameter. Red, Yellow & Blue colour wires shall be used for Phases R, Y, and B respectively. White or black colour wires shall be used for neutral connections. All technical parameters of the offered copper cable shall be as per IS: 694 and the tenderer shall mention in tender, all these technical parameters, including those not specified in the ISS. Each wire shall have pin lugs at meter end. Lugs should have compression joint with cable to establish a good electrical and mechanical contact. Lugs should be suitable for cable of 10mm<sup>2</sup> and should be made of Copper and coated with tin. Other end of each wire shall be fixed to Insulated bus

bars with 2 Nos. M6 bolt / stud duly zinc plated. Length of each wire shall be such that the Pin lug end of wire should be suitable for smallest and biggest meter. All the wires shall be properly dressed & tied together with cable nylon tie. The ends of cable should be provided with suitable cover to avoid short circuit in case of spare cables.

#### **4.0 TESTING FACILITIES:**

The tenderer must have the following minimum testing facilities in house: -

- i) High Voltage Tester.
- ii) High Current Source.
- iii) Megger
- iv) Powder Coating thickness Measuring instrument.
- v) Measuring instruments like Vernier, Micrometer, Measuring Tapes / Scales.
- vi) Facility for carrying out acceptance tests on copper cable as per IS: 694. In case a firm do not have this facility, the said tests on the copper cable shall be got carried out from Govt. / Independent test house/ works of the cable manufacturer, (subject to availability of the complete acceptance tests facilities) if a firm so desires.

#### **5.0 SAMPLING PLAN:**

One no sample per 100 nos pillar boxes of the offered lot shall be taken for carrying out pre-dispatch inspection by the inspecting officers.

#### **6.0 MARKING:**

Utility Name or Logo as shown in the drawing shall be embossed on the outer door and on the side opposite to the door on which door handle is fixed. Also manufacturers name should be embossed on the outer door with handle. Danger Notice as per Drawings should be printed in Red on outer door.

P.O. NO. & date and Sr. No. of MPB shall also be indelibly marked or embossed at a suitable place on the left door of MPBs, which should be of minimum 5mm height and clearly visible.

#### **7.0 INSPECTION:**

Each lot offered shall be inspected at the works of manufacturer by the inspecting officers of purchaser. The manufacturer shall give minimum 14 days' notice about readiness of material at his works for pre-dispatch inspection by the purchaser. The material shall be inspected for conformity with the specification before the same is accepted.

#### **8.0 TESTS:**

Following acceptance tests shall be carried out while inspecting lot of material offered.

##### **a) Visual Examination:**

The Meter Pillar box will be inspected visually, externally and internally for proper Powder Coating layer, fitting of all the components in accordance with technical Specification.

##### **b) Verification of dimensions:**

Verification of dimensions, external / internal clearances will be carried out as per technical specifications.

##### **c) Verification of fittings:**

Components like insulated bus bars, Lugs, Glass, Locks etc will be verified as per technical specification. Inspecting officers shall check that Angle Iron used for the angle iron frame & legs is manufactured by any 'BIS' approved manufacturer and record the same in inspection reports. A copy of ISI license of the angle iron shall be enclosed with inspection reports

**d) High voltage withstand test at 2.5KV:**

The A.C. voltage of 2.5KV, 50HZ shall be applied for one minute as follows:

- i) Between live parts of each insulated bus bars.
- ii) Between live part of each insulated bus bar and earthing bolts
- iii) On insulation of bus bars.
- iv) On PVC coating of PVC wires.

There shall not be any puncture or flash over during this test.

**e) Current Carrying Capacity:**

- i) The Current of 60Amp shall be applied for 30 minutes through high current source on the PVC cables. There shall not be overheating of the PVC cables during this test.
- ii) The current of 300Amp shall be applied for 30 minutes through high current source on each insulated bus bar. There shall not be overheating of the insulated bus bar during this test.

**f) Earth Continuity Checking Test:**

Earth Continuity shall be checked by Megger between two earthing terminals brought out on either side of Meter Pillar Box.

- g)** From the lot offered by the firm for inspection, sample of PVC cable shall be tested for complete acceptance tests as per IS-694:1990, at the works of the firm (if facility available). In case the testing facilities are not available with the firm, the samples shall be got tested from any Govt./ Independent Test House, for which samples shall be sealed by inspecting officers, at the cost of firm. Out of the offered lot of Pillar Boxes, 2 no. samples of copper cable shall be taken from 2 no sample pillar boxes for testing, which shall be to supplier's account. One no sample shall be tested/ sealed for sending the same to test house. The second sample shall be retained as counter sample. The tenderers shall indicate whether they propose in house acceptance testing of cable or from test house. Alternatively, the acceptance tests on the samples of copper cable can also be got carried out by inspecting officers at works of the cable manufacturer, (subject to availability of the complete acceptance tests facilities) if a firm so desires.

Inspecting officers shall check original documents regarding procurement of corresponding quality of ISI marked PVC copper cables for the offered lot of pillar boxes and attach an attested/signed photocopy of the said documents with each lot's inspection report. A copy of BIS license of the cable shall also be enclosed.

- 9.0** The box shall comply with the requirement of IP-33. The box shall be fully type tested for IP-33 with dimensions as per the requirement and IS 13947: 1993/other relevant standards, if any. The type test shall be carried out from the govt. approved laboratories. Government approved laboratories should be accredited by the National Board of Testing & Calibration Laboratories (NABL) of Govt. of India. The type test certificates must not have been issued earlier than three years from the original date of order.

**10.0 PACKING:**

Pillar Box shall be suitably wrapped to avoid damage in transit and handling. The Pillar boxes shall be suitably wrapped in 6mm to 8mm Expandable Poly Ethylene (EPE) foam and then shrink wrapped with Polythene Plastic sheet in order to avoid damage in transit and handling.

**11.0 Prototype & Drawings:-**

The manufacturer has to manufacturer the prototype Unit for each rating as per this specification before bulk manufacturing. The manufacturer should intimate the readiness of prototype to employer. The Project Manager will inspect the prototype for approval. The manufacturer should submit the final drawings in line with this specification and prototype to employer for approval before bulk manufacturing. The approval of prototype & drawings shall be a responsibility of manufacturer/Contractor. Tentative drawing of box is enclosed herewith.